

Computer Numerical Controls



**Fanuc AC Servo Amplifiers
 β i Series**

Description Manual

B-65322EN/02

- No part of this manual may be reproduced in any form.
- All specifications and designs are subject to change without notice.

In this manual we have tried as much as possible to describe all the various matters.

However, we cannot describe all the matters which must not be done, or which cannot be done, because there are so many possibilities.

Therefore, matters which are not especially described as possible in this manual should be regarded as "impossible".

SAFETY PRECAUTIONS

This "Safety Precautions" section describes the precautions which must be observed to ensure safety when using FANUC servo amplifiers (including spindle amplifiers). Users of any servo amplifier model are requested to read the "Safety Precautions" carefully before first using the amplifier. Users should also read the relevant description in this manual to become fully familiar with the functions of the servo amplifier.

The users are basically forbidden to do any behavior or action not mentioned in the "Safety Precautions." They are invited to ask FANUC previously about what behavior or action is prohibited.

Contents

1.1	DEFINITION OF WARNING, CAUTION, AND NOTE	s-2
1.2	WARNINGS AND CAUTIONS RELATING TO MOUNTING	s-3
1.2.1	Warning.....	s-3
1.2.2	Caution	s-5
1.2.3	Note	s-7
1.3	WARNINGS AND CAUTIONS RELATING TO A PILOT RUN	s-8
1.3.1	Warning.....	s-8
1.3.2	Caution	s-9
1.4	WARNINGS AND CAUTIONS RELATING TO MAINTENANCE.....	s-10
1.4.1	Warning.....	s-10
1.4.2	Caution	s-12
1.4.3	Note	s-13

1.1 DEFINITION OF WARNING, CAUTION, AND NOTE

This manual includes safety precautions for protecting the user and preventing damage to the machine. Precautions are classified into Warning and Caution according to their bearing on safety. Also, supplementary information is described as a Note. Read the Warning, Caution, and Note thoroughly before attempting to use the machine.

 **WARNING**

Applied when there is a danger of the user being injured or when there is a danger of both the user being injured and the equipment being damaged if the approved procedure is not observed.

 **CAUTION**

Applied when there is a danger of the equipment being damaged, if the approved procedure is not observed.

NOTE

The Note is used to indicate supplementary information other than Warning and Caution.

- Read this manual carefully, and store it in a safe place.

1.2 WARNINGS AND CAUTIONS RELATING TO MOUNTING

1.2.1 Warning

WARNING

- **Check the specification code of the amplifier.**
Check that the delivered amplifier is as originally ordered.
- **Mount a ground fault interrupter.**
To guard against fire and electric shock, fit the factory power supply or machine with a ground fault interrupter (designed for use with an inverter).
- **Securely ground the amplifier.**
Securely connect the ground terminal and metal frame of the amplifier and motor to a common ground plate of the power magnetic cabinet.
- **Be aware of the weight of the amplifier and other components.**
Servo amplifiers and AC reactors are heavy. When transporting them or mounting them in the cabinet, therefore, be careful not to injure yourself or damage the equipment. Be particularly careful not to jam your fingers between the cabinet and amplifier.
- **Never ground or short-circuit either the power supply lines or power lines.**
Protect the lines from any stress such as bending. Handle the ends appropriately.
- **Ensure that the power supply lines, power lines, and signal lines are securely connected.**
A loose screw, loose connection, or the like will cause a motor malfunction or overheating, or a ground fault.
Be extremely careful with power supply lines, motor power lines, and DC link connections through which a large amount of current passes, because a loose screw (or poor contact in a connector or poor connection between a connector terminal and a cable) may cause a fire.
- **Insulate all exposed parts that are charged.**
- **Never touch the regenerative discharge resistor or radiator directly.**
The surface of the radiator and regenerative discharge resistor become extremely hot. Never touch them directly. An appropriate structure should also be considered.

 **WARNING**

- **Close the amplifier cover after completing the wiring.**
Leaving the cover open presents a danger of electric shock.
- **Do not disassemble the amplifier.**
- **Ensure that the cables used for the power supply lines and power lines are of the appropriate diameter and temperature ratings.**
- **Do not apply an excessively large force to plastic parts.**
If a plastic section breaks, it may cause internal damage, thus interfering with normal operation. The edge of a broken section is likely to be sharp and, therefore, presents a risk of injury.

1.2.2 Caution

CAUTION

- **Do not step or sit on the amplifier.**
Also, do not stack unpacked amplifiers on top of each other.
- **Use the amplifier in an appropriate environment.**
See the allowable ambient temperatures and other requirements, given in the this manual.
- **Protect the amplifier from corrosive or conductive mist or drops of water.**
Use a filter if necessary.
- **Protect the amplifier from impact.**
Do not place anything on the amplifier.
- **Do not block the air inlet to the radiator.**
A deposit of coolant, oil mist, or chips on the air inlet will result in a reduction in the cooling efficiency. In some cases, the required efficiency cannot be achieved. The deposit may also lead to a reduction in the useful life of the semiconductors. Especially, when outside air is drawn in, mount filters on both the air inlet and outlet. These filters must be replaced regularly. So, an easy-to-replace type of filter should be used.
- **Connect the power supply lines and power lines to the appropriate terminals and connectors.**
- **Connect the signal lines to the appropriate connectors.**
- **Before connecting the power supply wiring, check the supply voltage.**
Check that the supply voltage is within the range specified in this manual, then connect the power supply lines.
- **Ensure that the combination of motor and amplifier is appropriate.**
- **Ensure that valid parameters are specified.**
Specifying an invalid parameter for the combination of motor and amplifier may not only prevent normal operation of the motor but also result in damage to the amplifier.
- **Ensure that the amplifier and peripheral equipment are securely connected.**
Check that the magnetic contactor, circuit breaker, and other devices mounted outside the amplifier are securely connected to each other and that those devices are securely connected to the amplifier.

 **CAUTION**

- **Check that the amplifier is securely mounted in the power magnetic cabinet.**
If any clearance is left between the power magnetic cabinet and the surface on which the amplifier is mounted, dust entering the gap may build up and prevent the normal operation of the amplifier.

- **Apply appropriate countermeasures against noise.**
Adequate countermeasures against noise are required to maintain normal operation of the amplifier. For example, signal lines must be routed away from power supply lines and power lines.

1.2.3 Note

NOTE

- **Keep the nameplate clearly visible.**
- **Keep the legend on the nameplate clearly visible.**
- **After unpacking the amplifier, carefully check for any damage.**
- **Mount the amplifier in a location where it can be easily accessed periodic inspection and daily maintenance.**
- **Leave sufficient space around the machine to enable maintenance to be performed easily.**
Do not place any heavy objects such that they would interfere with the opening of the doors.
- **Keep the parameter table and spare parts at hand.**
Also, keep the specifications at hand. These items must be stored in a location where they can be retrieved immediately.
- **Provide adequate shielding.**
A cable to be shielded must be securely connected to the ground plate, using a cable clamp or the like.

1.3 WARNINGS AND CAUTIONS RELATING TO A PILOT RUN

1.3.1 Warning

⚠ WARNING

- **Before turning on the power, check that the cables connected to the power magnetic cabinet and amplifier, as well as the power lines and power supply lines, are securely connected. Also, check that no lines are slack.**
- **Before turning on the power, ensure that the power magnetic cabinet is securely grounded.**
- **Before turning on the power, check that the door of the power magnetic cabinet and all other doors are closed.**
Ensure that the door of the power magnetic cabinet containing the amplifier, and all other doors, are securely closed. During operation, all doors must be closed and locked.
- **Apply extreme caution if the door of the power magnetic cabinet or another door must be opened.**
Only a person trained in the maintenance of the corresponding machine or equipment should open the door, and only after shutting off the power supply to the power magnetic cabinet (by opening both the input circuit breaker of the power magnetic cabinet and the factory switch used to supply power to the cabinet). If the machine must be operated with the door open to enable adjustment or for some other purpose, the operator must keep his or her hands and tools well away from any dangerous voltages. Such work must be done only by a person trained in the maintenance of the machine or equipment.
- **When operating the machine for the first time, check that the machine operates as instructed.**
To check whether the machine operates as instructed, first specify a small value for the motor, then increase the value gradually. If the motor operates abnormally, perform an emergency stop immediately.
- **After turning on the power, check the operation of the emergency stop circuit.**
Press the emergency stop button to check that the motor stops immediately, and that the power being supplied to the amplifier is shut off by the magnetic contactor.
- **Before opening a door or protective cover of a machine to enable adjustment of the machine, first place the machine in the emergency stop state and check that the motor has stopped.**

1.3.2 Caution

CAUTION

- **Note whether an alarm status relative to the amplifier is displayed at power-up or during operation.**
If an alarm is displayed, take appropriate action as explained in the maintenance manual. If the work to be done requires that the door of the power magnetic cabinet be left open, the work must be carried out by a person trained in the maintenance of the machine or equipment. Note that if some alarms are forcibly reset to enable operation to continue, the amplifier may be damaged. Take appropriate action according to the contents of the alarm.
- **Before operating the motor for the first time, mount and adjust the position and speed sensors.**
Following the instructions given in the maintenance manual, adjust the position and speed sensors for the spindle so that an appropriate waveform is obtained.
If the sensors are not properly adjusted, the motor may not rotate normally or the spindle may fail to stop as desired.
- **If the motor makes any abnormal noise or vibration while operating, stop it immediately.**
Note that if operation is continued in spite of there being some abnormal noise or vibration, the amplifier may be damaged. Take appropriate corrective action, then resume operation.
- **Observe the ambient temperature and output rating requirements.**
The continuous output rating or continuous operation period of some amplifiers may fall as the ambient temperature increases. If the amplifier is used continuously with an excessive load applied, the amplifier may be damaged.

1.4 Warnings and Cautions Relating to Maintenance

1.4.1 Warning

WARNING

- **Read the maintenance manual carefully and ensure that you are totally familiar with its contents.**

The maintenance manual describes daily maintenance and the procedures to be followed in the event of an alarm being issued. The operator must be familiar with these descriptions.

- **Notes on replacing a fuse or PC board**
 - 1) Before starting the replacement work, ensure that the circuit breaker protecting the power magnetic cabinet is open.
 - 2) Check that the red LED that indicates that charging is in progress is not lit.

The position of the charging LED on each model of amplifier is given in this manual. While the LED is lit, hazardous voltages are present inside the unit, and thus there is a danger of electric shock.
 - 3) Some PC board components become extremely hot. Be careful not to touch these components.
 - 4) Ensure that a fuse having an appropriate rating is used.
 - 5) Check the specification code of a PC board to be replaced. If a modification drawing number is indicated, contact FANUC before replacing the PC board.

Also, before and after replacing a PC board, check its pin settings.
 - 6) After replacing the fuse, ensure that the screws are firmly tightened. For a socket-type fuse, ensure that the fuse is inserted correctly.
 - 7) After replacing the PC board, ensure that it is securely connected.
 - 8) Ensure that all power lines, power supply lines, and connectors are securely connected.

- **Take care not to lose any screws.**

When removing the case or PC board, take care not to lose any screws. If a screw is lost inside the unit and the power is turned on, the machine may be damaged.

 **WARNING**

- **Notes on replacing the battery of the absolute Pulsecoder**
Replace the battery only while the power is on. If the battery is replaced while the power is turned off, the stored absolute positioning data will be lost. Some βi series servo amplifier modules have batteries in their servo amplifiers. To replace the battery of any of those models, observe the following procedure: Open the door of the power magnetic cabinet; Leave the control power of the power supply module on; Place the machine in the emergency stop state so that the power being input to the amplifier is shut off; Then, replace the battery. Replacement work should be done only by a person who is trained in the related maintenance and safety requirements. The power magnetic cabinet in which the servo amplifier is mounted has a high-voltage section. This section presents a severe risk of electric shock.
- **Check the alarm number.**
If the machine stops upon an alarm being issued, check the alarm number. Some alarms indicate that a component must be replaced. If the power is reconnected without first replacing the failed component, another component may be damaged, making it difficult to locate the original cause of the alarm.
- **Before resetting an alarm, ensure that the original cause of the alarm has been removed.**
- **Contact FANUC whenever a question relating to maintenance arises.**
- **Notes on removing the amplifier**
Before removing the amplifier, first ensure that the power is shut off. Be careful not to jam your fingers between the power magnetic cabinet and amplifier.

1.4.2 Caution

CAUTION

- **Ensure that all required components are mounted.**
When replacing a component or PC board, check that all components, including the snubber capacitor, are correctly mounted. If the snubber capacitor is not mounted, for example, the IPM will be damaged.
- **Tighten all screws firmly.**
- **Check the specification code of the fuse, PC board, and other components.**
When replacing a fuse or PC board, first check the specification code of the fuse or PC board, then mount it in the correct position. The machine will not operate normally if a fuse or PC board having other than the correct specification code is mounted, or if a fuse or PC board is mounted in the wrong position.
- **Mount the correct cover.**
The cover on the front of the amplifier carries a label indicating a specification code. When mounting a previously removed front cover, take care to mount it on the unit from which it was removed.
- **Notes on cleaning the heat sink and fan**
 - 1) A dirty heat sink or fan results in reduced semiconductor cooling efficiency, which degrades reliability. Periodic cleaning is necessary.
 - 2) Using compressed air for cleaning scatters the dust. A deposit of conductive dust on the amplifier or peripheral equipment will result in a failure.
 - 3) To clean the heat sink, do so only after turning the power off and ensuring that the heat sink has cooled to room temperature. The heat sink becomes extremely hot, such that touching it during operation or immediately after power-off is likely to cause a burn. Be extremely careful when touching the heat sink.
- **Unless otherwise specified, do not insert or remove any connector while the power is turned on. Otherwise, the amplifier may fail.**

1.4.3 Note

NOTE

- **Ensure that the battery connector is correctly inserted.**
If the power is shut off while the battery connector is not connected correctly, the absolute position data for the machine will be lost.

- **Store the manuals in a safe place.**
The manuals should be stored in a location where they can be accessed immediately if so required during maintenance work.

- **Notes on contacting FANUC**
Inform FANUC of the details of an alarm and the specification code of the amplifier so that any components required for maintenance can be quickly secured, and any other necessary action can be taken without delay.

TABLE OF CONTENTS

SAFETY PRECAUTIONS	s-1
I. SVM	
1 OVERVIEW	3
2 CONFIGURATION	4
2.1 SVM1-4 <i>i</i> AND SVM1-20 <i>i</i>	5
2.2 SVM1-40 <i>i</i> AND SVM1-80 <i>i</i>	6
2 CONFIGURATION	4
2.1 SVM1-4 <i>i</i> AND SVM1-20 <i>i</i>	5
2.2 SVM1-40 <i>i</i> AND SVM1-80 <i>i</i>	6
3 SPECIFICATIONS	7
3.1 SPECIFICATIONS.....	8
3.2 APPLICABLE MOTORS	8
3.3 SELECTING CIRCUIT BREAKER, MAGNETIC CONTACTOR, AND AC LINE FILTER	9
3.3.1 Selecting Circuit Breaker	9
3.3.2 Selecting Magnetic Contactor	10
3.3.3 AC Line Filter	10
3.4 COOLING FAM MOTORS	11
3.4.1 Models Requiring Cooling Fan motors	11
3.4.2 Installing a Separate Cooling Fan motor	11
3.5 DERATING	12
3.6 SEPARATED REGENERATIVE DISCHARGE RESISTOR.....	13
3.6.1 When No Separated Regenerative Discharge Resistor Is Needed.....	13
3.6.2 When a Separated Regenerative Discharge Resistor Is Needed.....	15
3.6.3 When Amplifier Models SVM-40 <i>i</i> and SVM-80 <i>i</i> Are Used.....	17
4 ORDERING INFORMATION	22
5 POWER SUPPLY	23
5.1 INPUT POWER SUPPLY	24
5.1.1 Three-phase Input Power Supply for Motor Power	24
5.1.2 Single-phase Input Power Supply for Motor Power.....	24
5.1.3 Single-phase Input for Control Power.....	24
5.2 POWER TRANSFORMER FOR EXPORTS.....	28

5.2.1	Specification.....	28
5.2.2	How to Select a Transformer.....	29
6	INSTALLATION CONDITIONS AND NOTES.....	30
6.1	ENVIRONMENTAL CONDITIONS	31
6.2	SELECTING A GROUND-FAULT CIRCUIT INTERRUPTER.....	32
6.3	NOISE PROTECTION	33
6.3.1	Separation of Signal Lines	33
6.3.2	Grounding.....	34
6.3.3	Noise Suppressor.....	35
6.3.4	Cable Clamp and Shield Processing.....	36
6.4	INSTALLING LIGHTNING SURGE ABSORBERS	39
7	PROTECTIVE GROUNDING.....	42
7.1	SVM1-4 <i>i</i> and SVM1-20 <i>i</i> (FSSB Interface)	43
7.2	SVM1-40 <i>i</i> and SVM1-80 <i>i</i> (FSSB Interface)	44
8	EXTERNAL DIMENSIONS / PANEL CUT-OUT DRAWINGS / MAINTENANCE AREA	45
8.1	EXTERNAL DIMENSIONS	46
8.1.1	External Dimensions of SVM1-4 <i>i</i> and SVM1-20 <i>i</i>	46
8.1.2	External Dimensions of SVM1-40 <i>i</i> and SVM1-80 <i>i</i>	47
8.1.3	External Dimensions of Fan Unit (A06B-6134-K003)	48
8.1.4	External Dimensions of Fan Unit (A06B-6134-K002)	49
8.1.5	Discharge Resistor.....	50
8.1.6	AC Line Filter	53
8.1.7	Transformer for Exports.....	55
8.1.8	Battery Case	55
8.1.9	Lightning Surge Absorbers	56
8.2	PANEL CUT-OUT DRAWINGS	58
8.2.1	SVM1-4 <i>i</i> and SVM1-20 <i>i</i>	58
8.2.2	SVM1-40 <i>i</i> and SVM1-80 <i>i</i>	59
8.2.3	Discharge Resistor.....	60
8.3	MAINTENANCE AREA.....	62
8.3.1	Maintenance Area for the SVM1-4 <i>i</i> and SVM1-20 <i>i</i>	62
8.3.2	Maintenance Area for the SVM1-40 <i>i</i> and SVM1-80 <i>i</i>	63
9	TOTAL CONNECTION DIAGRAM.....	65
9.1	CONNECTION DIAGRAM.....	66
9.1.1	SVM1-4 <i>i</i> and SVM1-20 <i>i</i>	66

9.1.2	SVM1-40 <i>i</i> and SVM1-80 <i>i</i>	68
9.2	CONNECTOR LOCATION	70
9.2.1	SVM1-4 <i>i</i> and SVM1-20 <i>i</i>	70
9.2.2	SVM1-40 <i>i</i> and SVM1-80 <i>i</i>	71
9.2.3	Connection Tools	72
9.2.4	Details of Cable K1	73
9.2.4.1	Servo motor αi , αis series, Servo motor βis series ($\beta 0.4/5000is$ to $\beta 22/2000is$).....	73
9.2.4.2	Servo motor βis series ($\beta 0.2/5000is$, $\beta 0.3/5000is$).....	75
9.2.5	Details of Cable K2	77
9.2.5.1	Details of connectors	77
9.2.5.2	Selecting cables (general)	80
9.2.5.3	Details of input cables	81
9.2.6	Details of Cable K3	82
9.2.6.1	Details of connectors	82
9.2.6.2	Details of cables (general)	83
9.2.6.3	Power cable for servo motor.....	84
9.2.7	Details of Cables K4 and K5	85
9.2.7.1	SVM1-4 <i>i</i> and SVM1-20 <i>i</i>	85
9.2.7.2	SVM1-40 <i>i</i> and SVM1-80 <i>i</i>	87
9.2.8	Details of Cable K6	89
9.2.9	Details of Cable K7	90
9.2.10	Details of Cable K8	91
9.2.11	Details of Cable K9	93
9.2.12	Details of Cable K10	94
9.2.13	Details of Cable K11	96
9.3	HANDLING OF EXTERNAL MAGNETIC CONTACTORS.....	97
10	HEAT DISSIPATION	98
 II. SVPM		
1	OVERVIEW	101
2	CONFIGURATION	102
3	SPECIFICATIONS.....	103
3.1	SPECIFICATIONS.....	104
3.2	COOLING FAN MOTOR.....	106
3.3	HOW TO OBTAIN A POWER SUPPLY CAPACITY.....	106
3.4	APPLICABLE MOTORS	107
3.5	CIRCUIT BREAKER, MAGNETIC CONTACTOR, AND AC REACTOR....	108

3.5.1	AC Line Filter and Magnetic Contactor.....	108
3.5.2	AC Reactor.....	109
3.6	SPINDLE AXIS TYPES (#A AND #C) AND APPLICABLE SENSORS.....	110
3.7	DERATING.....	111
4	ORDERING INFORMATION	112
5	POWER SUPPLY	113
5.1	INPUT POWER SUPPLY	114
5.1.1	Three-phase Input Power Supply for Motor Power	114
5.1.2	Single-phase Input for Control Power.....	115
5.2	POWER TRANSFORMER FOR EXPORTS.....	116
6	INSTALLATION CONDITIONS AND NOTES.....	119
6.1	ENVIRONMENTAL CONDITIONS	120
6.2	Selecting a Ground-Fault Circuit Interrupter	120
6.3	NOISE PROTECTION	120
6.4	INSTALLING LIGHTNING SURGE ABSORBERS	121
7	PROTECTIVE GROUNDING.....	123
8	EXTERNAL DIMENSIONS / PANEL CUT-OUT DRAWINGS / MAINTENANCE AREA	124
8.1	EXTERNAL DIMENSIONS	125
8.1.1	External Dimensions of SVPM.....	125
8.1.2	External Dimensions of Fan Unit (A06B-6134-K001)	125
8.1.3	AC Reactor Unit.....	126
8.1.4	Power Transformer.....	127
8.1.5	Circuit Breaker	130
8.1.6	Magnetic Contactors.....	131
8.1.7	Lightning Surge Protector	133
8.2	PANEL CUT-OUT DRAWINGS	134
8.3	MAINTENANCE AREA.....	136
8.4	DUCT.....	138
9	TOTAL CONNECTION DIAGRAM.....	140
9.1	CONNECTION DIAGRAM.....	140
9.2	CONNECTOR LOCATION	141
9.3	DETAILED DESCRIPTIONS OF CONNECTIONS	142
9.3.1	Common.....	142
9.3.1.1	Details of cable K1	142

9.3.1.2	Details of cable K6	144
9.3.1.3	Details of cable K7	145
9.3.1.4	Details of cable K69	146
9.3.1.5	Details of cable K70	146
9.3.1.6	Details of cable K21	148
9.3.1.7	Details of cable K22	150
9.3.1.8	Details of cable K27	152
9.3.1.9	Details of cable K28	153
9.3.2	Spindle Motor	155
9.3.2.1	Details of cable K10	155
9.3.2.2	Details of cable K12	156
9.3.2.3	Details of cable K14	158
9.3.2.4	Details of cable K16	160
9.3.2.5	Details of cable K17	162
9.3.2.6	Details of cable K33	164
9.3.2.7	Details of cable K71	169
9.3.2.8	Details of cable K79	172
9.4	DETAILS OF CONNECTORS	173
9.4.1	20-Pin Half-Pitch Connectors	173
9.4.2	Tyco Electronics AMP D-5000 Series Connector.....	174
10	HEAT DISSIPATION	176
11	POWER CABLE FOR SERVO MOTOR AND AMPLIFIER	179
11.1	SELECTING A POWER CABLE	180
11.2	SAMPLE POWER CABLES SELECTED FOR SERVO MOTORS (REFERENCE)	182
11.3	SAMPLE POWER CABLES SELECTED FOR SPINDLE MOTORS (REFERENCE)	182
III. I/O Link		
1	OVERVIEW	185
2	CONFIGURATION	186
2.1	SVM1-4 <i>i</i> AND SVM1-20 <i>i</i>	187
2.2	SVM1-40 <i>i</i> AND SVM1-80 <i>i</i>	188
3	SPECIFICATIONS.....	189
3.1	SPECIFICATIONS.....	190
3.2	APPLICABLE MOTORS	191
3.3	SELECTING CIRCUIT BREAKER, MAGNETIC CONTACTOR, AND AC LINE FILTER	191

3.3.1	Selecting Circuit Breaker	191
3.3.2	Selecting Magnetic Contactor	191
3.3.3	Selecting AC Line Filter.....	191
3.4	COOLING FAM MOTORS.....	192
3.4.1	Installing the Cooling Fan Motor in the SVM1-4 <i>i</i> and SVM1-20 <i>i</i>	192
3.4.2	SVM1-80 <i>i</i>	192
3.5	DERATING	193
3.6	SEPARATED REGENERATIVE DISCHARGE RESISTOR.....	193
4	ORDERING INFORMATION	194
5	POWER SUPPLY	195
5.1	INPUT POWER SUPPLY	196
5.1.1	Three-phase Input Power Supply for Motor Power	196
5.1.2	Single-phase Input Power Supply for Motor Power.....	196
5.1.3	Control Power	196
5.1.3.1	Sequence for turning on control power supply.....	196
5.2	POWER TRANSFORMER FOR EXPORTS	196
6	INSTALLATION CONDITIONS AND NOTES	197
7	GROUNDING	198
7.1	SVM1-4 <i>i</i> AND SVM1-20 <i>i</i>	199
7.2	SVM1-40 <i>i</i> and SVM1-80 <i>i</i>	200
8	EXTERNAL DIMENSIONS / PANEL CUT-OUT DRAWINGS / MAINTENANCE AREA	201
8.1	EXTERNAL DIMENSIONS	202
8.1.1	SVM1-4 <i>i</i> and SVM1-20 <i>i</i>	202
8.1.2	SVM1-40 <i>i</i> and SVM1-80 <i>i</i>	203
8.1.3	Fan Unit (A06B-6134-K002).....	204
8.1.4	Separated Regenerative Discharge Resistor	204
8.1.5	AC Line Filter	204
8.1.6	Transformer for Exports.....	204
8.1.7	Battery Case (for Size D Alkaline Battery).....	204
8.1.8	Lightning Surge Absorbers	204
8.2	PANEL CUT-OUT DRAWINGS	204
8.3	MAINTENANCE AREA.....	205
8.3.1	Maintenance Area for the SVM1-4 <i>i</i> and SVM1-20 <i>i</i>	205
8.3.2	Maintenance Area for the SVM1-40 <i>i</i>	205

8.3.3	Maintenance Area for the SVM1-80i	205
9	TOTAL CONNECTION DIAGRAM.....	206
9.1	CONNECTION DIAGRAM	207
9.1.1	SVM1-4i and SVM1-20i	207
9.1.2	SVM1-40i and SVM1-80i	209
9.1.3	SVM1-4i and SVM1-20i	211
9.1.4	SVM1-40i and SVM1-80i	213
9.2	CONNECTOR LOCATION	215
9.2.1	SVM1-4i and SVM1-20i	215
9.2.2	SVM1-40i and SVM1-80i	216
9.2.3	Connection Tools	217
9.2.4	Details of Cable K1	217
9.2.4.1	Servo motor αi , αis series, Servo motor βis series ($\beta 0.4/5000is$ to $\beta 22/2000is$).....	217
9.2.4.2	Servo motor βis series ($\beta 0.2/5000is$, $\beta 0.3/5000is$).....	218
9.2.5	Details of Cable K2	219
9.2.6	Details of Cable K3	219
9.2.7	Details of Cables K4 and K5	219
9.2.8	Details of Cable K6	219
9.2.9	Details of Cable K7	220
9.2.9.1	Connection of external magnetic contactor when βi SVM FSSB interface is used together	221
9.2.10	Details of Cable K8	222
9.2.11	Details of Cable K9	222
9.2.12	Details of Cable K10	222
9.2.13	Details of Cable K11	222
9.2.14	Details of Cable K20 (Connection of FANUC I/O Link)	223
9.2.14.1	Overview	223
9.2.14.2	Connection of FANUC I/O Link by electric cable	224
9.2.14.3	Connection of FANUC I/O Link by optical fiber cable	225
9.2.15	Details of Cable K21 (Internal DI Connection)	226
9.2.15.1	Signals	226
9.2.15.2	*+OT, *-OT, and *RILK(*DEC)	227
9.2.15.3	Skip signal interface	228
9.2.16	Connection to External Pulse Generator	229
9.2.16.1	Connection when differential type A/B phase pulse generator is used.....	230
9.2.16.2	Connection when FANUC's manual pulse generator is used	231
9.2.17	Connection to Servo Check Board	238

10 HEAT DISSIPATION	239
----------------------------------	------------

APPENDIX

A CONNECTING THE REACTOR AND LINE FILTER	243
A.1 OVERVIEW	244
A.2 CONNECTION EXAMPLES	245

I. SVM

1

OVERVIEW

The βi SVM FSSB interface has the following features:

- (1) Because a power supply is incorporated, a compact system can be built for 1- or 2-axis machining.
- (2) One-axis AC servo system with excellent cost performance
- (3) The FSSB interface, which is the standard interface of FANUC, is supported.
- (4) This unit has a small installation area and volume.
- (5) The unit is designed in compliance with the following safety standards:
 - EN50178
 - UL508C
 - CSA C22.2
 - EN61000-6-2
 - EN55011
- (6) This one-axis AC servo amplifier is suitable for the servo motor βi series, which is suitable for feed axes of machining tools and for applications of their peripheral equipment and industrial machines, and the servo motor αi series, which is suitable for feed axes.

2 CONFIGURATION

2.1 SVM1-4i AND SVM1-20i

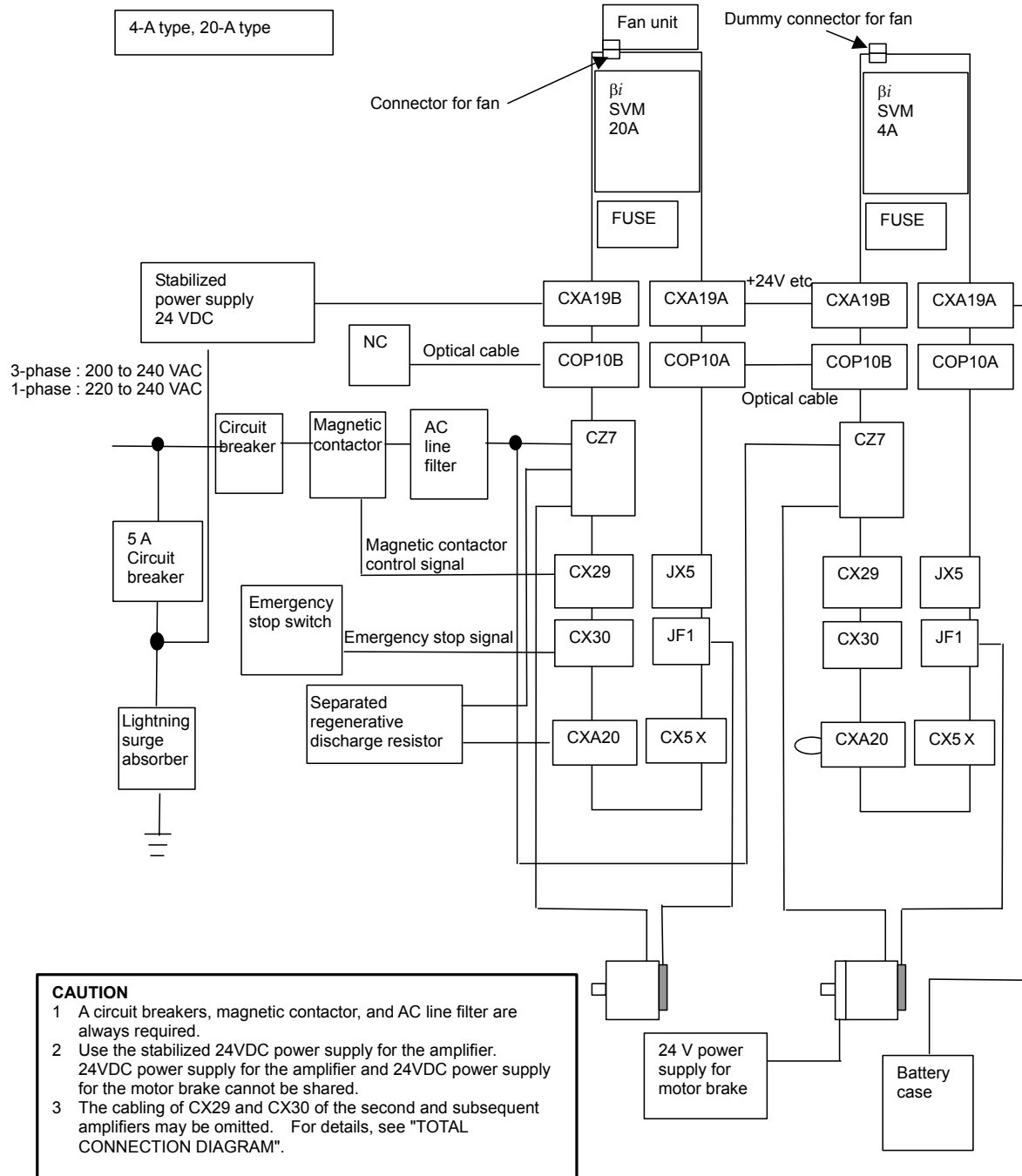

2.2 SVM1-40i AND SVM1-80i

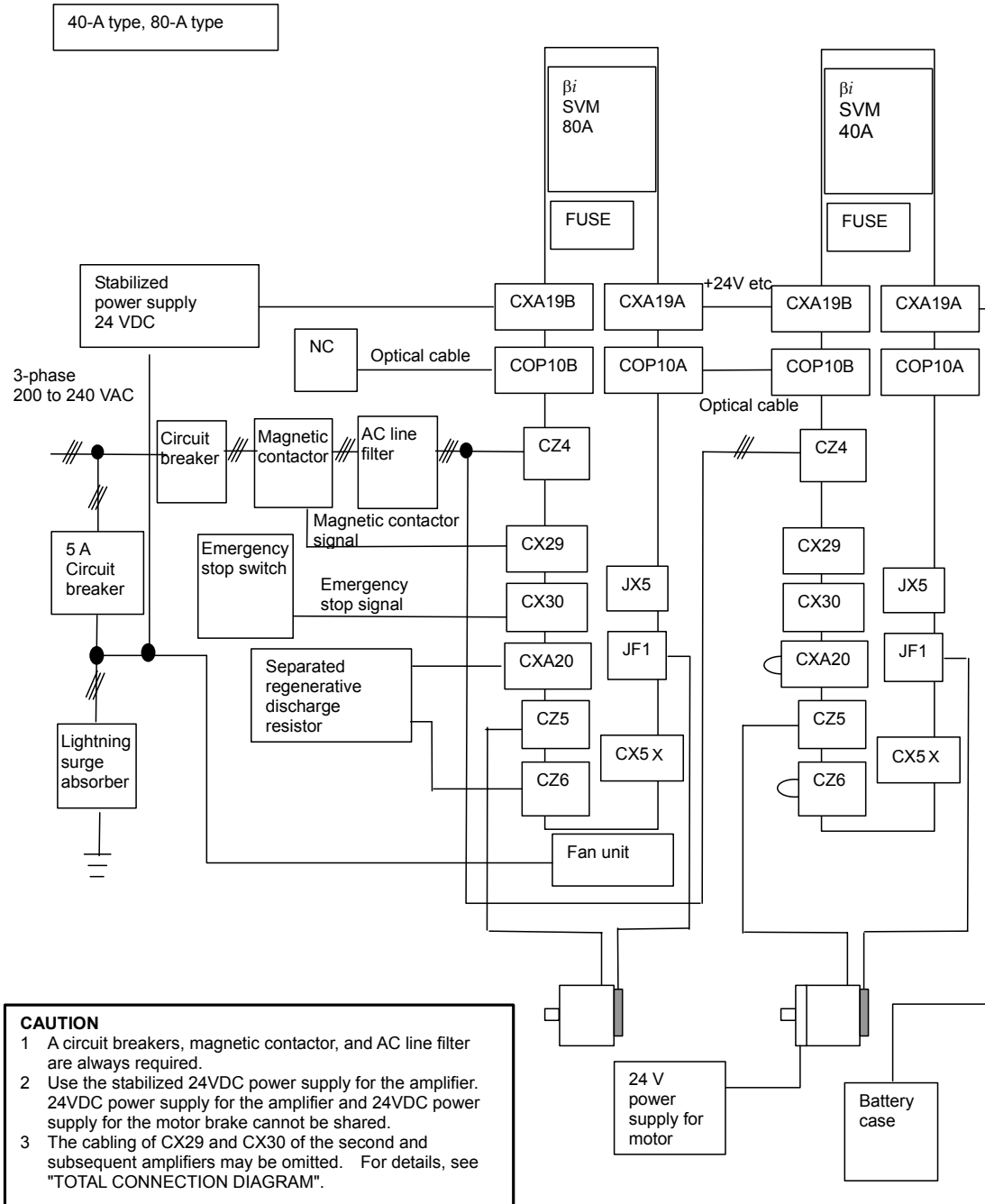

3

SPECIFICATIONS

3.1 SPECIFICATIONS

Item	SVM-4i	SVM-20i	SVM1-40i	SVM1-80i	
Interface	FSSB				
Unit drawing No.	A06B-6130-H001	A06B-6130-H002	A06B-6130-H003	A06B-6130-H004	
Power PC board drawing No.	A20B-2101-0090	A20B-2101-0091	A16B-3200-0512	A16B-3200-0513	
Control PC board drawing No.	A20B-2101-0050				
Main power supply 3-phase input	Input voltage 200-240 VAC (+10%,-15%) 50 / 60 Hz				
	Input current (50 Hz)	0.5 Arms	8.0 Arms	14.0Arms	19.0Arms
	Power supply rating	0.2 kVA	2.8 kVA	4.7kVA	6.5kVA
Main power supply Single-phase input	Input voltage 220-240 VAC (+10%,-15%) 50/60 Hz				
	Input current (50 Hz)	1.1Arms	8.0Arms	-	-
	Power supply rating	0.3 kVA	1.9 kVA	-	-
Control power supply	Input voltage 24 VDC (+10%, -10%)				
	Input current	0.9 Arms			
Rated output current	0.9Arms	6.8Arms	13Arms	18.5Arms	
Maximum output current	4Ap	20 Ap	40 Ap	80 Ap	
Servo HRV control	HRV2, HRV3				
Control method	Sine Wave PWM Control with Transistor Bridges				
Dynamic brake circuit	Included				
Output frequency range	0-334Hz				
Protection function	- High Current - IPM Abnormal - High Voltage of DC Link - Low Voltage of DC Link - Overheat of Discharge Resistor - Low Voltage of Control Power Supply - FSSB Communication Error - Locked Fan Motor				
Ambient temperature range	0°C to +55°C				
Weight	1.2kg		3.9kg		
Remarks	Separated regenerative resistor (30 Ω, 20W/100W) Separate AC line filter Separate battery		Built-in regenerative resistor (16 Ω, 50 W, no-wind condition) (16 Ω, 130 W, wind velocity of 2m/s) Separated regenerative resistor (16 Ω, 200 W to 1200W) Separate AC line filter Separate battery		

3.2 APPLICABLE MOTORS

		0.2	0.3	0.4	0.5	1	2	4	8	12	22	
Motor	αi					$\alpha 1/$ 5000i (20A)	$\alpha 2/$ 5000i (20A)		$\alpha 4/$ 4000i (40A)	$\alpha 8/$ 3000i (40A)	$\alpha 12/$ 3000i (80A)	$\alpha 22/$ 3000i (80A)
	αis						$\alpha 2/$ 5000is (20A)	$\alpha 4/$ 5000is (20A)		$\alpha 8/$ 4000is (80A)	$\alpha 12/$ 4000is (80A)	
	βis	$\beta 0.2/$ 5000is (4A)	$\beta 0.3/$ 5000is (4A)	$\beta 0.4/$ 5000is (20A)	$\beta 0.5/$ 5000is (20A)	$\beta 1/$ 5000is (20A)	$\beta 2/$ 4000is (20A)	$\beta 4/$ 4000is (20A)		$\beta 8/$ 3000is (20A)	$\beta 12/$ 3000is (40A)	$\beta 22/$ 2000is (40A)
SVM1	SVM1-4i	o	o									
	SVM1-20i			o	o	o	o	o	o			
	SVM1-40i							o	o	o	o	o
	SVM1-80i									o	o	o

3.3 SELECTING CIRCUIT BREAKER, MAGNETIC CONTACTOR, AND AC LINE FILTER

3.3.1 Selecting Circuit Breaker

Select a circuit breaker based on the continuous current ratings of the individual motors listed below. When connecting more than one amplifier, determine the rating of the circuit breaker based on the sum of the continuous current ratings of the motors.

When the motor accelerates or decelerates rapidly, current about three times as high as the continuous current rating may flow for approximately three seconds. So, select a circuit breaker that does not trip under such current flow conditions.

WARNING

Because of a possibility of cable burning, consider protection co-ordination of the cables between the circuit breaker output and the input of each amplifier and the selected circuit breaker.

Table Input current for continuous output rating

Servo motor	Continuous current rating with 3-phase input [Arms] (Reference)	Power supply rating with 3-phase input [kVA] (Reference)	Continuous current rating with single-phase input [Arms] (Reference)	Power supply rating with single-phase input [kVA] (Reference)
$\beta 0.2/5000is$	0.2	0.08	0.5	0.12
$\beta 0.3/5000is$	0.5	0.15	1.1	0.25
$\beta 0.4/5000is$	0.6	0.20	1.4	0.32
$\beta 0.5/5000is$	0.9	0.31	2.2	0.49
$\beta 1/5000is$	1.8	0.62	4.3	1.0
$\beta 2/4000is$	2.2	0.77	5.4	1.2
$\beta 4/4000is$	3.3	1.2	8.1	1.9
$\beta 8/3000is$	5.4	1.9	9.7	2.2
$\beta 12/3000is$	8.0	2.8	-	-
$\beta 22/2000is$	11.1	3.9	-	-
$\alpha 1/5000i$	2.2	0.77	5.4	1.2
$\alpha 2/5000i$	3.3	1.2	8.1	1.9
$\alpha 4/4000i$	6.2	2.2	-	-
$\alpha 8/3000i$	7.1	2.5	-	-
$\alpha 12/3000i$	13.4	4.6	-	-
$\alpha 22/3000i$	17.8	6.2	-	-
$\alpha 2/5000is$	3.3	1.2	8.1	1.9
$\alpha 4/5000is$	4.5	1.5	9.7	2.2
$\alpha 8/4000is$	11.1	3.9	-	-
$\alpha 12/4000is$	12.0	4.2	-	-

3.3.2 Selecting Magnetic Contactor

Select a magnetic contactor according to the table, "Input current for continuous output rating". When connecting more than one amplifier, make a selection based on the sum of the continuous current ratings of the motors.

Manufacturer's specification (Fuji Electric)	Rated current
SC-5-1	19A
SC-N1	26A



WARNING

For details, refer to the brochure supplied by Fuji Electric Co., Ltd.

3.3.3 AC Line Filter

Select an AC line filter according to the table, "Input current for continuous output rating". When connecting more than one amplifier, make a selection based on the sum of the continuous current ratings of the motors.

To reduce the influence of high frequency noise on the power supply, be sure to use an AC line filter or EMC noise filter. The LF series manufactured by TOKIN is available as the EMC noise filter.

AC line filter	Continuous current rating	Continuous output rating	Heat dissipation
A81L-0001-0083#3C	24A	5.4kW or less	20W
A81L-0001-0101#C	44A	10.5kW or less	70W
A81L-0001-0102	100A	23kW or more	50W



WARNING

The AC line filter is different from the AC reactor. Neither substitution between them nor use of one of them for both purposes is allowed.

3.4 COOLING FAN MOTORS

3.4.1 Models Requiring Cooling Fan motors

The combinations listed below require cooling fan motors.

Ordering number	Amplifier	Combined motor
A06B-6134-K002	SVM1-80 <i>i</i>	General 80-A class motors
A06B-6134-K003	SVM1-20 <i>i</i> Running on 3-phase 200-240 VAC power	α 4/5000 <i>is</i> β 8/3000 <i>is</i>
	SVM1-20 <i>i</i> Running on 1-phase 220-240 VAC power	α 2/5000 <i>i</i> α 2/5000 <i>is</i> α 4/5000 <i>is</i> β 4/4000 <i>is</i> β 8/3000 <i>is</i>

3.4.2 Installing a Separate Cooling Fan motor

When using one of the above combinations that require a cooling fan motor, install an optionally available fan motor in the order (1), (2), and (3) as illustrated below.

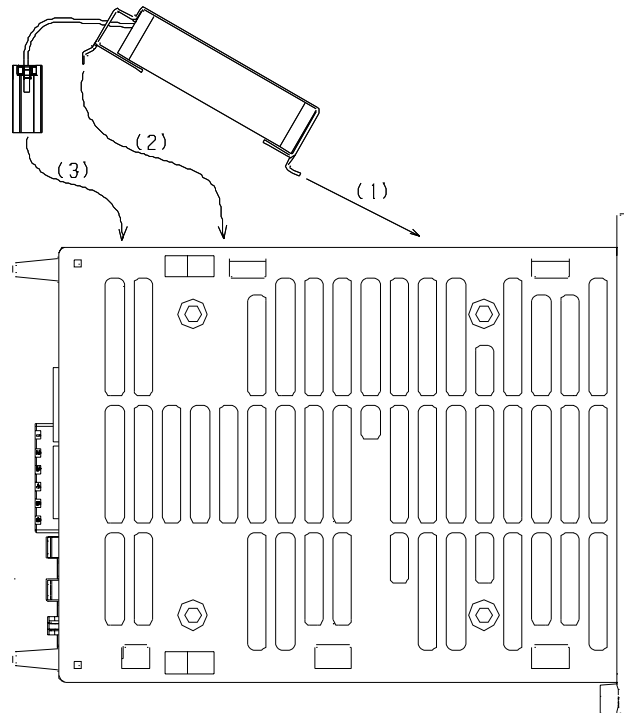

3.5 DERATING

Consider derating as shown below, according to ambient temperatures.

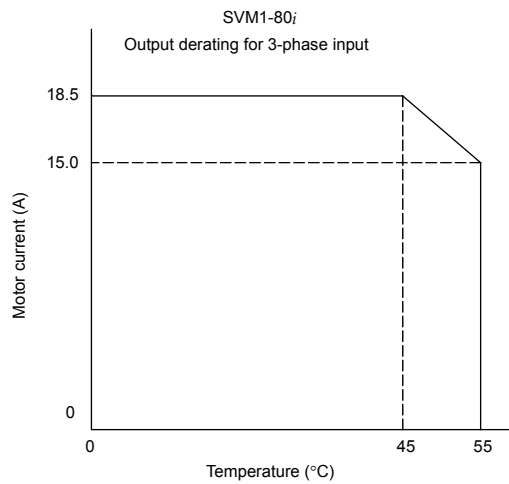
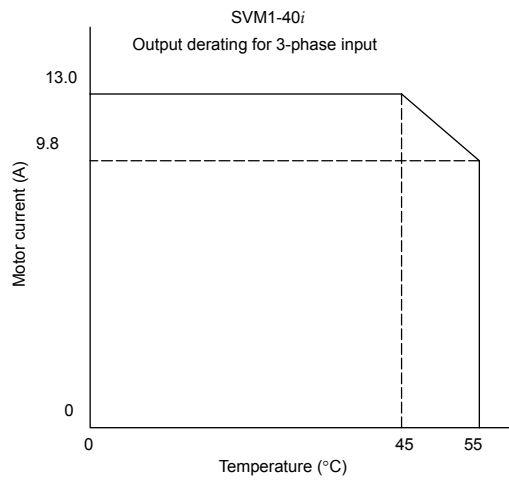
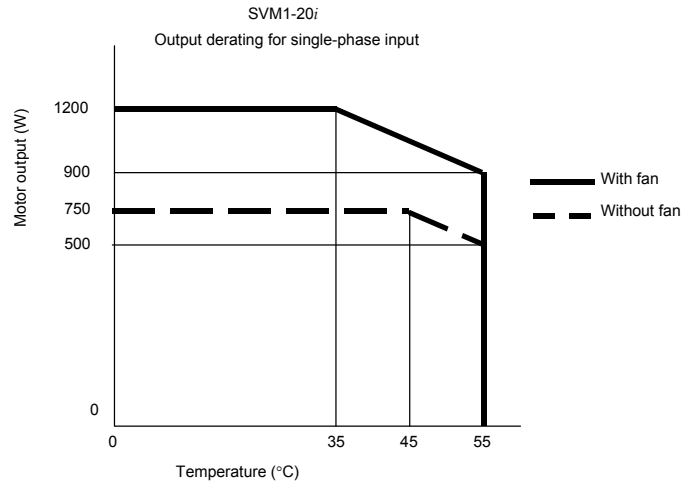

3.6 SEPARATED REGENERATIVE DISCHARGE RESISTOR

3.6.1 When No Separated Regenerative Discharge Resistor Is Needed

No separated regenerative discharge resistor is needed if the energy regenerated per regeneration cycle is not higher than the amount [J] of energy listed below.

Note in mind that an incorrect connection can damage the amplifier.

Table 3.6.1 Maximum regenerative energy amount permitted for individual amplifier models

Amplifier model	Permissible regenerative energy amount
SVM-4i SVM-20i	16 [J]

How to calculate the amount of energy regenerated per regeneration cycle - For horizontal movement

(a) SI unit system

$$P = (5.48 \times 10^{-3} \cdot (Jm + JL) \cdot Vm^2 - 5.23 \times 10^{-2} \cdot ta \cdot Vm \cdot TL) [J] \quad (\text{Expression 1})$$

Jm: Rotor inertia of the motor [kg·m²]

JL: Motor-shaft-converted inertia of the load [kg·m²]

Vm: Motor speed at rapid traverse [min⁻¹]

ta: Rapid traverse acceleration/deceleration time [sec]

TL: Machine frictional torque (motor-converted value) [N·m]

(b) CGS unit system

$$P = (5.37 \times 10^{-4} \cdot (Jm + JL) \cdot Vm^2 - 5.13 \times 10^{-3} \cdot ta \cdot Vm \cdot TL) [J] \quad (\text{Expression 1})$$

Jm: Rotor inertia of the motor [kgf·cm·sec²]

JL: Motor-shaft-converted inertia of the load [kgf·cm·sec²]

Vm: Motor speed at rapid traverse [min⁻¹]

ta: Rapid traverse acceleration/deceleration time [sec]

TL: Machine frictional torque (motor-converted value) [kg·cm]

- For vertical movement

(a) SI unit system

$$Q = 1.047 \times 10^{-1} \cdot Th \cdot Vm \cdot ta \text{ [J]} \quad (\text{Expression 2})$$

Th: Upward torque that the motor applies at the time of downward rapid traverse [N·m]

Vm: Motor speed at rapid traverse [min⁻¹]

ta : Rapid traverse acceleration/deceleration time [sec]

(b) CGS unit system

$$Q = 1.026 \times 10^{-2} \cdot Th \cdot Vm \cdot ta \text{ [J]} \quad (\text{Expression 2})$$

Th: Upward torque that the motor applies at the time of downward rapid traverse [kg·cm]

Vm: Motor speed at rapid traverse [min⁻¹]

ta : Rapid traverse acceleration/deceleration time [sec]

If the motor load moves up and down, the sum of expressions 1 and 2 gives the amount of energy regenerated per regeneration cycle.

$$R = P + Q \text{ [J]} \quad (\text{Expression 3})$$

3.6.2 When a Separated Regenerative Discharge Resistor Is Needed

If the amount of energy regenerated per regeneration cycle exceeds the maximum amount of energy that a servo amplifier can handle, a DC link overvoltage alarm occurs. In this case, a separated regenerative discharge resistor is needed.

Note in mind that an incorrect connection can damage the amplifier.

Selecting a regenerative discharge resistor

First obtain how much regenerative energy occurs.

- For horizontal movement

Servo motor (for horizontal movement)

Amount of regenerative discharge (power [W]) when rapid traverse acceleration/deceleration is performed once every F sec

(a) SI unit system

$$w1 = \frac{1}{F} \times (5.48 \times 10^{-3} \cdot (Jm + JL) \cdot Vm^2 - 5.23 \times 10^{-2} \cdot ta \cdot Vm \cdot TL) [W] \quad (\text{Expression 4})$$

F: Frequency of rapid traverse acceleration/deceleration

[sec/number of times]

Unless otherwise specified, rapid traverse acceleration/deceleration is assumed to be performed about once every 5 seconds.

Jm: Rotor inertia of the motor [kg·m²]

JL: Motor-shaft-converted inertia of the load [kg·m²]

Vm: Motor speed at rapid traverse [min⁻¹]

ta: Rapid traverse acceleration/deceleration time [sec]

TL: Machine frictional torque (motor-converted value) [N·m]

(b) CGS unit system

$$w1 = \frac{1}{F} \times (5.37 \times 10^{-4} \cdot (Jm + JL) \cdot Vm^2 - 5.13 \times 10^{-3} \cdot ta \cdot Vm \cdot TL) [W] \quad (\text{Expression 4})$$

F: Frequency of rapid traverse acceleration/deceleration

[sec/number of times]

Unless otherwise specified, rapid traverse acceleration/deceleration is assumed to be performed about once every 5 seconds.

Jm: Rotor inertia of the motor [kgf·cm·sec²]

JL: Motor-shaft-converted inertia of the load [kgf·cm·sec²]

Vm: Motor speed at rapid traverse [min⁻¹]

ta: Rapid traverse acceleration/deceleration time [sec]

TL: Machine frictional torque (motor-converted value) [kg·cm]

From Table 3.6.2, select a separated regenerative discharge unit having a greater regenerative discharge capacity than the value obtained from (Expression 4).

- For vertical movement

The amount of regenerative discharge (power [W]) when the operation duty for downward rapid traverse is D(%)

(a) SI unit system

$$w_2 = 1.047 \times 10^{-1} \cdot Th \cdot Vm \times \frac{D}{100} [W] \quad (\text{Expression 5})$$

Th: Upward torque that the motor applies at the time of downward rapid traverse [N·m]

Vm: Motor speed at rapid traverse [min⁻¹]

D: Operation duty [%] for downward rapid traverse

D is set to 50% maximum. Usually, D is less than 50%.

(b) CGS unit system

$$w_2 = 1.026 \times 10^{-2} \cdot Th \cdot Vm \times \frac{D}{100} [W] \quad (\text{Expression 5})$$

Th: Upward torque that the motor applies at the time of downward rapid traverse [kg·cm]

Vm: Motor speed at rapid traverse [min⁻¹]

D: Operation duty [%] for downward rapid traverse

D is set to 50% maximum. Usually, D is less than 50%.

If the motor load moves up and down, the sum of expressions 4 and 5 gives the amount of energy regenerated per regeneration cycle.

$$w = w_1 + w_2 [W] \quad (\text{Expression 6})$$

From Table 3.6.2, select a separated regenerative discharge resistor whose regenerative discharge capacity is larger than the regenerative energy obtained in expression 6.

Table 3.6.2 Regenerative discharge capacity of separated regenerative discharge resistors

Separated regenerative discharge resistor	Regenerative discharge capacity	Condition
A06B-6130-H401 (30 Ω)	20 W	Wind speed of 0 m/s
(Caution) A06B-6130-H402 (30 Ω)	100 W	

CAUTION

Do not use a regenerative resistor cable longer than 1 m. Otherwise, it is likely that the regenerative circuit in the amplifier may malfunction or the amplifier may be damaged.

NOTE

If the permissible value of a separated regenerative discharge resistor is exceeded during use, the unit overheats, resulting in the built-in thermostat operating to issue an overheat alarm.

3.6.3 When Amplifier Models SVM-40i and SVM-80i Are Used

If the amount of regenerative discharge from a servo motor exceeds the regenerative discharge capacity of the regenerative discharge resistor incorporated in the corresponding servo amplifier, a separated regenerative discharge resistor is needed.

If the motor regenerative discharge amount R obtained in Subsection 3.6.2 exceeds the corresponding value listed in Table 3.6.3 (a), “Regenerative discharge capacity of the regenerative discharge resistor incorporated in servo amplifiers,” use a separated regenerative discharge resistor.

Table 3.6.3 (a) Regenerative discharge capacity of the regenerative discharge resistor incorporated in servo amplifiers

Servo amplifier	Capacity
A06B-6130-H003	50 W
A06B-6130-H004	130 W

The following table lists the separated regenerative discharge resistors that are available.

Select a separated regenerative discharge resistor whose discharge capacity satisfies your requirement.

Table 3.6.3(b) Regenerative discharge capacity of regenerative discharge resistors installed separately from servo amplifiers

Separated regenerative discharge resistor	Wind speed of 0 m/s	Wind speed of 2 m/s	Wind speed of 4 m/s
A06B-6089-H500	$R = 200W$	$R = 400 W$	$R = 600 W$
A06B-6089-H713	Incorporates a cooling fan motor.		$R = 800 W$
A06B-6089-H714	Incorporates a cooling fan motor.		$R = 1200 W$

Set-up switch (for changing the DC alarm level)

Switch setting (for the SVM1-40i and SVM1-80i)

The SVM1-40i and SVM1-80i each have four switches on their front panel for protecting regenerative resistors. Be sure to set these switches to the positions that match the resistors used.



CAUTION

An incorrect switch setting may damage the regenerative resistor.

These switches are numbered 1 to 4. The one on top is No. 1, the one below it is No. 2, and so on. When the lever of a switch is at the left, the switch is on. When it is at the right, the switch is off.

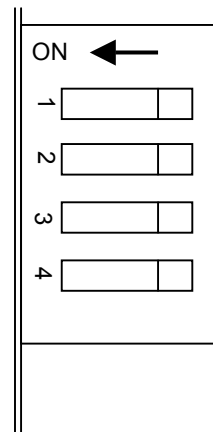

(1) Setting of switches 3 and 4

The setting of switches 3 and 4 varies depending on what regenerative discharge resistor is used.

⇒ If a switch is incorrectly set up, it is impossible to detect a regenerative overheat alarm normally.

Switch 3	Switch 4	Regenerative discharge resistor
ON	ON	Incorporated in the amplifier
OFF	ON	Separate unit A06B-6089-H500
OFF	OFF	Separate unit A06B-6089-H713, A06B-6089-H714

(2) Setting of switches 1 and 2

Neither switch 1 nor 2 is used. Leave them off.

Cautions for selecting a regenerative discharge resistor

WARNING

- 1 Regenerative discharge resistors may become very hot (100 to 200 °C). Be careful not to touch them.
- 2 Before touching a regenerative discharge resistor, for example, for maintenance purposes, turn off all power to the amplifier, wait for at least 30 minutes, and make sure that the DC link charge indicator LED (CAUTION CHARGE) is off and the regenerative resistor is sufficiently cold.
- 3 When mounting a regenerative resistor, keep it sufficiently far from any flammable.

(1) Related ordering numbers

Ordering number of regenerative discharge resistor	Resistance	Capacity			Remarks
		Wind speed			
		0 m/s	2 m/s	4 m/s	
A06B-6130-H401	30 Ω	20 W	-	-	For 4/20 A
A06B-6130-H402	30 Ω	100 W	-	-	For 4/20 A
A06B-6089-H500	16 Ω	200 W	400 W	600 W	For 40/80 A
A06B-6089-H713	16 Ω	Incorporates a cooling fan motor.		800 W	For 40/80 A
A06B-6089-H714	16 Ω	Incorporates a cooling fan motor.		1200 W	For 40/80 A

(2) Mounting requirements

(a) Cautions in mounting

A06B-6130-H401	Install these models in a completely sealed cabinet.
A06B-6130-H402	
A06B-6089-H500	Place the pin side and resistor side (heat generating section) of these models, respectively, in a completely sealed cabinet and an exhaust air duct.
A06B-6089-H713	
A06B-6089-H714	(a) Use accompanying gaskets. (b) Make arrangements so that the pin side and resistor side (heat generating section) can be kept from coolant, oil mist, and cuttings. (c) When taking in fresh air to the resistor (heat generating section), use an air filter at the air inlet. Also seal the cable inlets, cable outlets and doors securely.

- (b) Ambient temperature
 - 0 to 55 °C (at operation)
 - 20 to 60 °C (at keeping and transportation)
- (c) Humidity
 - Normally 90 % RH or below, and condensation-free
- (d) Vibration
 - In operation : Below 0.5 G
- (e) Mounting direction:
 - Mount the unit securely while referring to the mounting diagram given below.

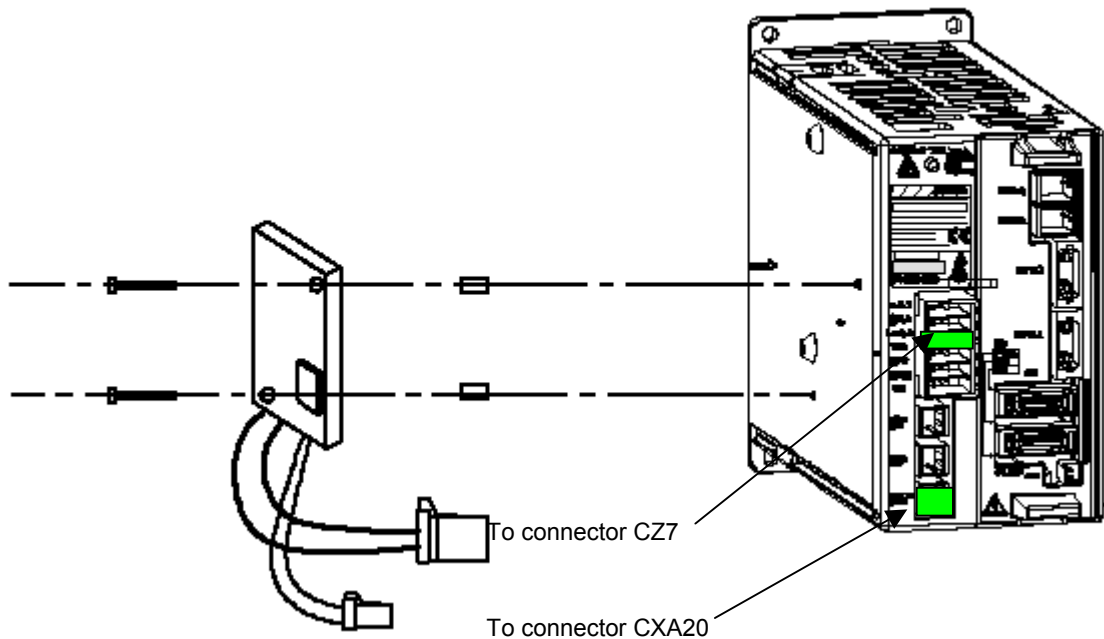
Installation and connection of A06B-6130-H401**⚠ WARNING**

- 1 Regenerative discharge resistors may become very hot (100 to 200 °C). Be careful not to touch them.
- 2 Before touching a regenerative discharge resistor, for example, for maintenance purposes, turn off all power to the amplifier, wait for at least 30 minutes, and make sure that the DC link charge indicator LED (CAUTION CHARGE) is off and the regenerative resistor is sufficiently cold.
- 3 When mounting a regenerative resistor, keep it sufficiently far from any flammable.
- 4 The minimum clearance between the regenerative resistor and the wall should be 10 mm.

Installation and connection of A06B-6130-H402

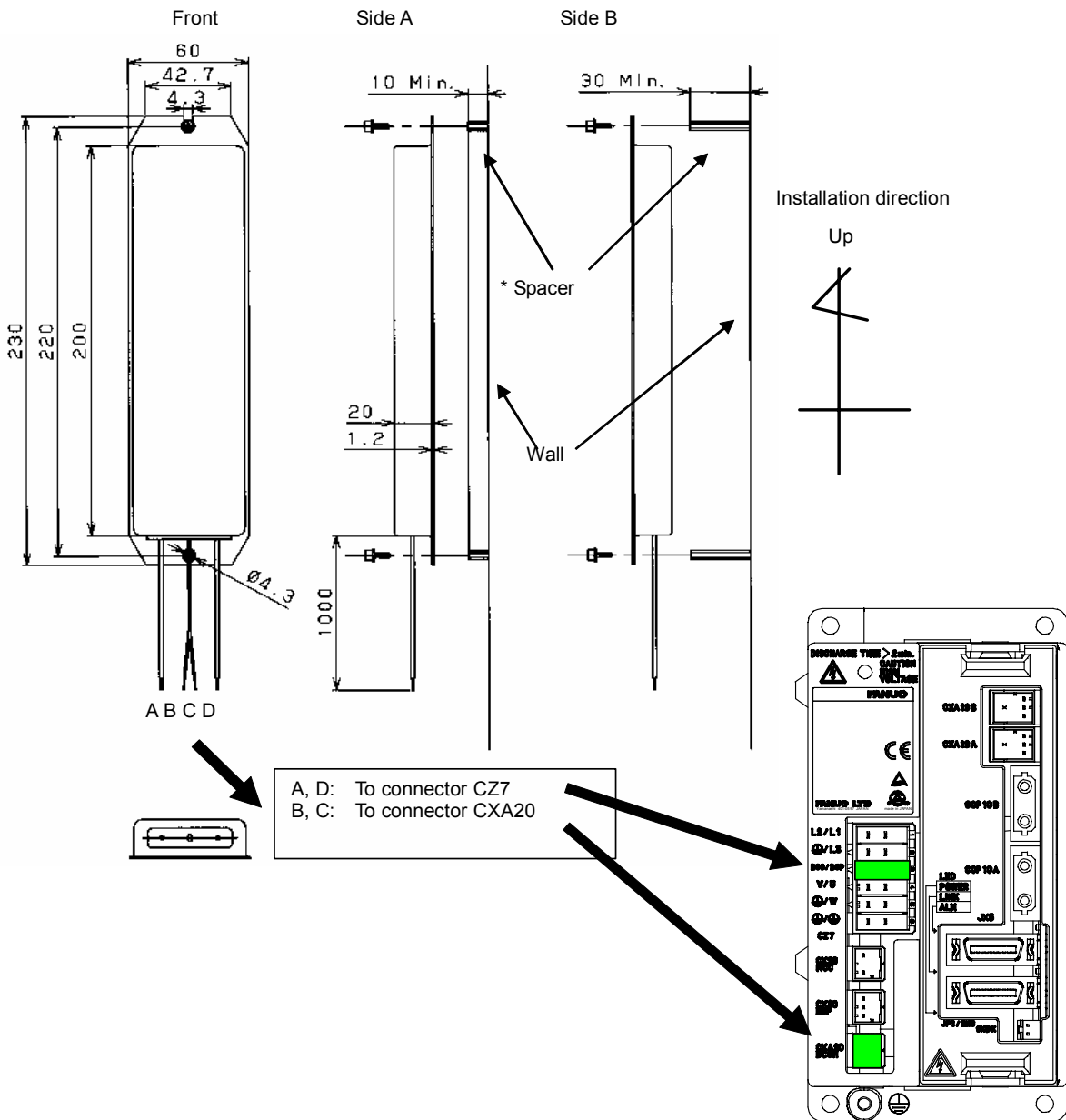

- ⚠ WARNING**
- 1 Regenerative discharge resistors may become very hot (100 to 200 °C). Be careful not to touch them.
 - 2 Before touching a regenerative discharge resistor, for example, maintenance purposes, turn off all power to the amplifier, wait for at least 30 minutes, and make sure that the DC link charge indicator LED (CAUTION CHARGE) is off and the regenerative discharge resistor has been cooled down enough.
 - 3 When mounting a regenerative resistor, keep it sufficiently far from any flammable.
 - 4 The minimum clearance between the regenerative resistor and the wall should be 10 mm.

4

ORDERING INFORMATION

Refer to the order list (B-65321EN).

5

POWER SUPPLY

5.1 INPUT POWER SUPPLY

5.1.1 Three-phase Input Power Supply for Motor Power

- Nominal rated voltage: 200 to 240 VAC
- Allowable voltage fluctuation: -15% to +10%
- Frequency: 50/60 Hz
- Allowable frequency fluctuation: ± 2 Hz
- Power supply impedance: Voltage fluctuation caused by load (at maximum output) not to exceed 7%
- Power supply unbalance: Within $\pm 5\%$ of the rated voltage

NOTE

The allowable voltage fluctuation is a change observed for several minutes. It is not a continuous change.

5.1.2 Single-phase Input Power Supply for Motor Power

In European countries, power sources are 380 to 415 VAC and neutral-grounded. To use the βi series amplifiers in these European countries, it is necessary to install a power transformer at the input or supply single-phase power.

To use the motors with single-phase power, observe the following:

Only the SVM1-20*i* and lower models can support single-phase input. The other models use the three-phase input power supply specifications only.

(1) Power supply specification

- Nominal voltage rating: 220 to 240 VAC
- Allowable voltage fluctuation: -15% to +10%
- Frequency: 50/60 Hz
- Allowable frequency fluctuation: ± 2 Hz
- Voltage fluctuation at acceleration/deceleration: 7% or less

NOTE

The allowable voltage fluctuation is a change observed for several minutes. It is not a continuous change.

5.1.3 Single-phase Input for Control Power

Be sure to use a stabilized power supply as the 24-V power supply for amplifiers. The 24-V power supply for motor brakes cannot be shared.

- Nominal rated voltage: 24VDC
- Allowable voltage fluctuation: $\pm 10\%$ (including momentary variations)
- Power supply ratings

	Power supply rating per amplifier
FSSB interface	0.9A

- External 24-VDC power supply specifications

Recommended external 24-VDC power supply (stabilized power supply) specifications (UL1950 must be satisfied.)

Output voltage +24V \pm 10% (21.6V to 26.4V)
(Including ripple voltage and noise. See the figure below.)

Output current The continuous load current must be at least the current consumption of the CNC and other units.

(at a highest temperature in the power magnetics cabinet where the power supply is installed)

Load variation (including surge current)

The above output voltage range must not be exceeded by load variation.

AC input hold time at momentary disconnection

10mS (for -100%)

20mS (for -50%)

Permissible time of momentary 24-VDC disconnection

0.5mS (less than 21.6 V)

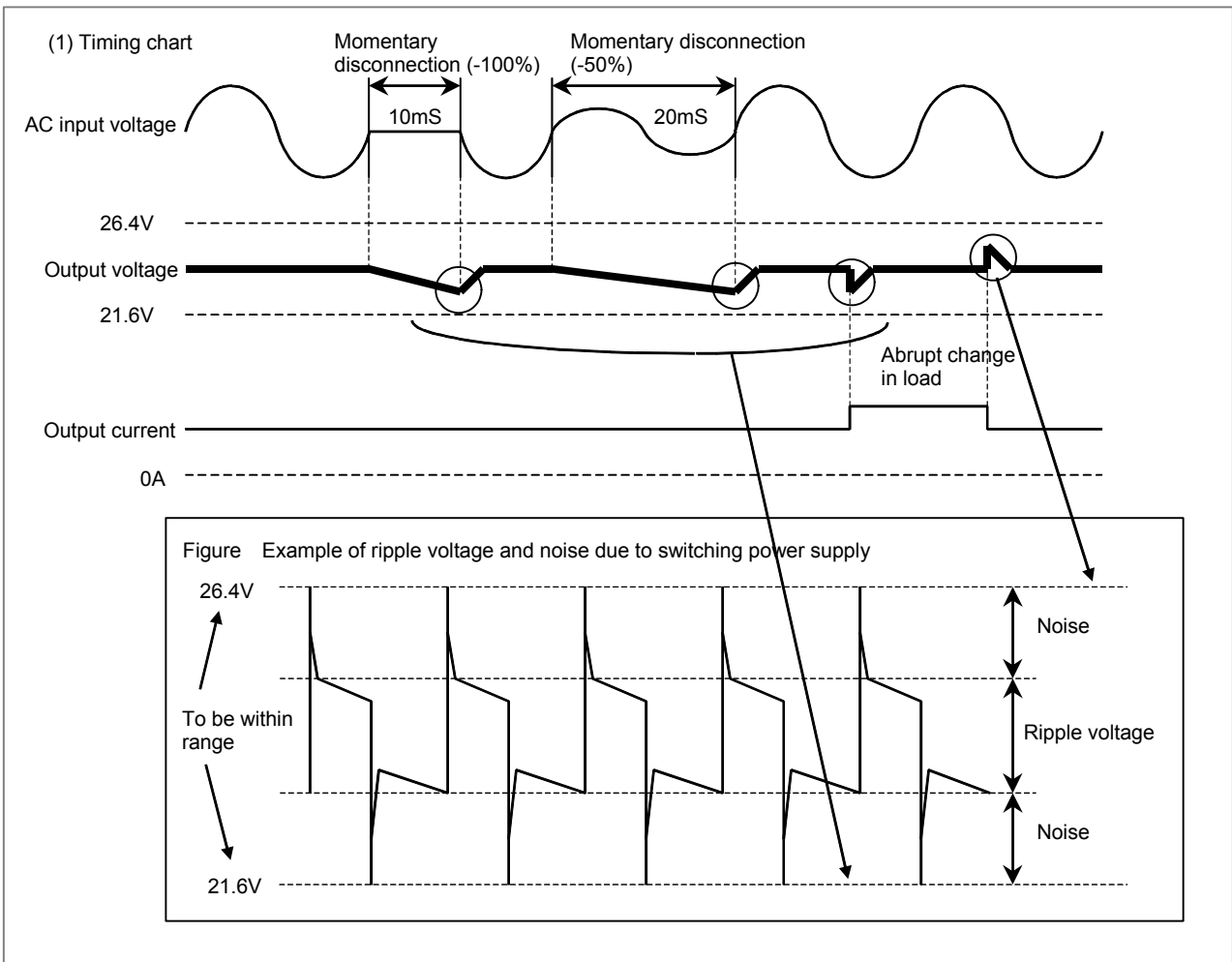

Timing chart

- Circuit configuration

The circuit configuration shown in <1> and <2> below are not permitted.

Prohibited

<1> Circuit examples in which the output voltage cannot be held at the time of momentary disconnection (the voltage level lowers below 21.6 V)

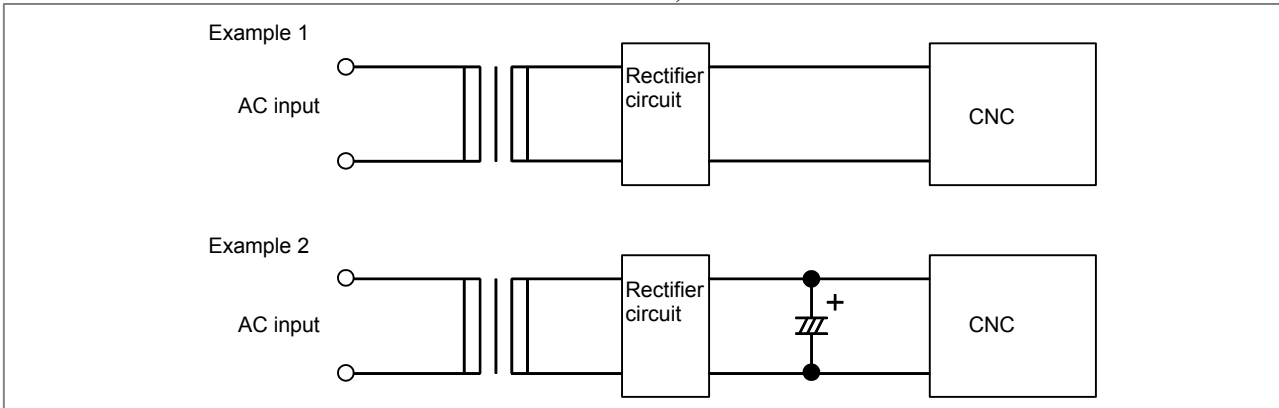

NOTE
A rectifier circuit performs full-wave rectification by using diodes.

<2> Circuit examples in which the output voltage specification (21.6 V to 26.4 V) is exceeded by abrupt change in load

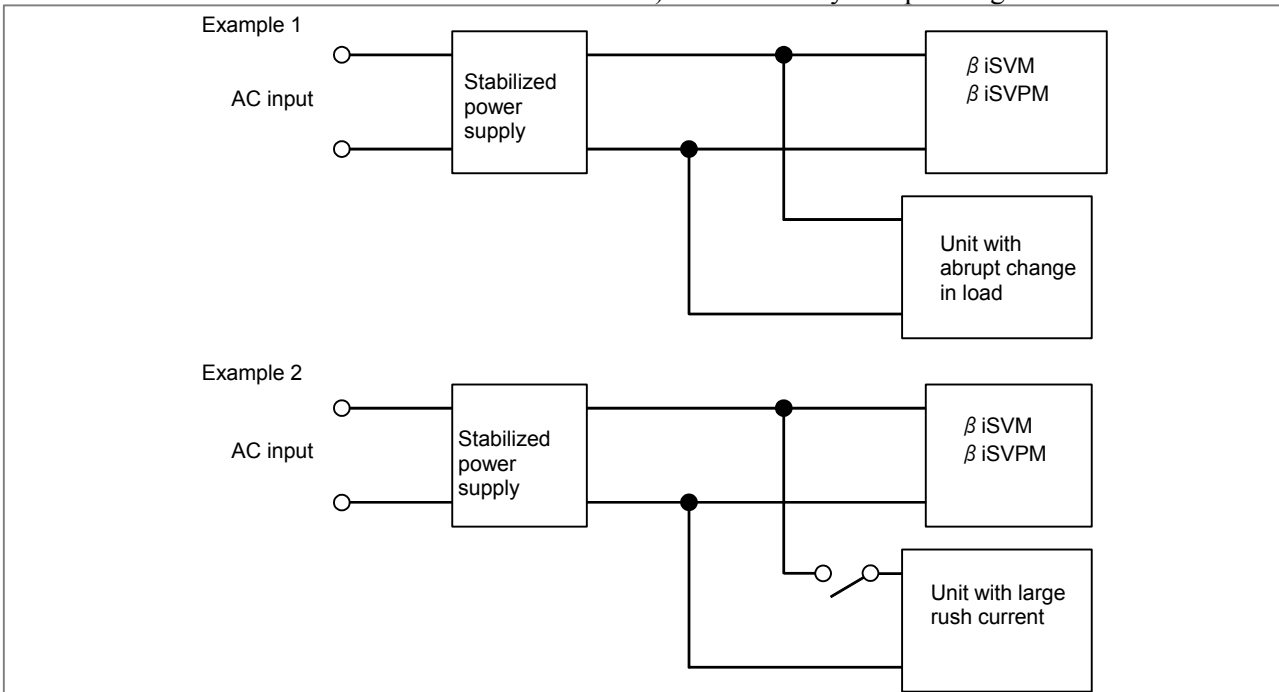

In case of <2>, prepare an additional stabilized power supply dedicated to a unit whose load changes abruptly, so that the βi SVM and βi SVPM are not affected.

5.2 POWER TRANSFORMER FOR EXPORTS

Use power transformer for an export when this servo amplifier unit is used at a site where the line voltage is other than 200 to 240 VAC.

5.2.1 Specification

Table 5.2.1 Specification of power transformer

Ordering drawing number	A80L-0022-0005	A80L-0024-0006	A80L-0026-0003	A80L-0028-0001
FANUC drawing number	A80L-0022-0005	A80L-0024-0006	A80L-0026-0003	A80L-0028-0001
Rated capacity	2.2kVA	3.5kVA	5kVA	7.5kVA
Rated primary voltage	200/220/230/240VAC (Δ connection) 380/415/460/480/550VAC (Y connection) $\pm 15\%$, 50/60Hz ± 2 Hz; 3 ϕ			
Rated secondary voltage	210VAC			
Rated secondary current	6.1A	9.6A	13.7A	20.6A
Voltage regulation at the secondary	2%			
Voltage deviation at the secondary	$\pm 3\%$			
Connection	Δ - Δ connection or Y- Δ connection			
Insulation	Class B (maximum allowable temperature : 130°C)			
Ambient temperature	-20 to 55°C			
Allowable temperature rise	135deg			
Relative humidity	Max. 95%RH			
Type	Dry type, natural air cooling type			
Dielectric withstand voltage	2300VAC, for 1 minute			
Weight	Max. 21kg	Max. 27kg	Max.36kg	Max. 42kg
Outline drawing	Fig. 8.1.3			

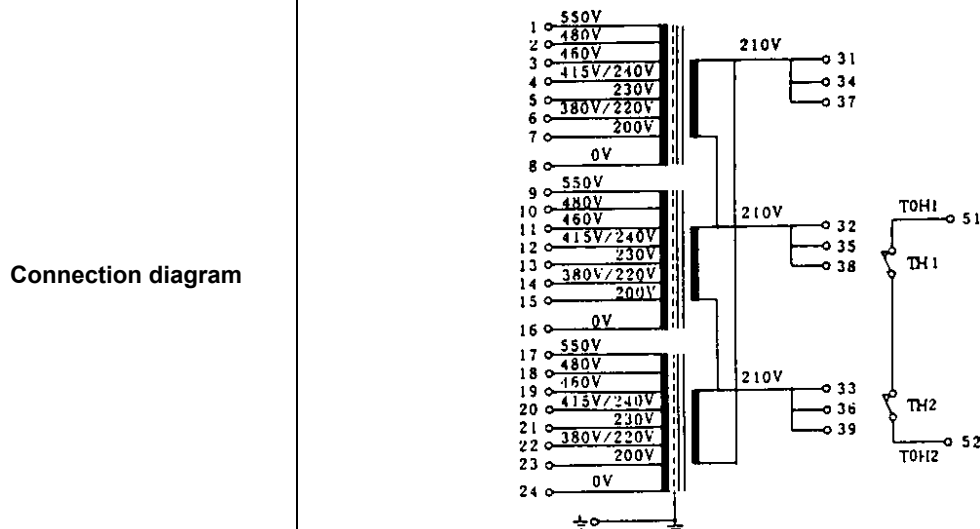

5.2.2 How to Select a Transformer

Select a transformer according to the load condition and the model of the motor for which the transformer is used. Each transformer has secondary winding taps for three amplifiers so that it can be connected to two or three amplifiers.

When connecting more than one amplifier, make a selection based on the sum of the continuous current ratings of the individual motors.

6

INSTALLATION CONDITIONS AND NOTES

6.1 ENVIRONMENTAL CONDITIONS

Install a βi setting servo amplifier in a completely closed cabinet so that the environment conditions indicated below can be satisfied.

- (1) Ambient Temperature
 - Ambient temperature
 - 0 to 55°C (operating)
 - 20 to 60°C (storage and transportation)
 - Ambient temperature of the accommodation cabinet 0 to 45°C
- (2) Humidity
 - Usually, 95% RH or lower (no condensation)
- (3) Vibration
 - No more than 0.5G during operation
- (4) Atmosphere
 - Ensure that the electronic circuits are not exposed to corrosive and conductive mist and waterdrops. (Note)
- (5) Notes on installation
 - When installing an amplifier, consider the following:
 - (a) Ensure that the heat sink is not exposed to coolant, oil mist, cuttings, and so forth. Otherwise, the cooling efficiency can degrade, resulting in a failure to satisfy the characteristics of the amplifier. Moreover, the life of semiconductors can be adversely affected.
 - To introduce the open air for the heat sink, use an air filter at the inlet.
 - Ensure that the cable inlet and outlet, door, and so forth are sealed.

NOTE

The electronic circuits must be installed in an environment of contamination level 2 defined in IEC60664-1.

In order to satisfy contamination level 2 in a severe environment for using machine tools, the servo amplifier β series must be installed in a cabinet that satisfy IP54.

If the cabinet does not have a structure for preventing materials that adversely affect amplifiers from getting into the cabinet, normal operation and safety may fail. So, special care should be taken.

- (b) Ensure that dust, coolant, and so forth do not penetrate through the exhaust vent. Moreover, ensure that the flow of cooling wind is not interrupted.
- (c) Ensure that the servo amplifier β series can be inspected, removed, and reinstalled easily in maintenance.

6.2 SELECTING A GROUND-FAULT CIRCUIT INTERRUPTER

Because the servo amplifier βi series uses the PWM inverter system by transistors to drive a motor, high frequency leakage current flows via the motor winding, power cable, and amplifier floating capacity to ground. This may cause the ground-fault circuit interrupter or ground-fault protective relay installed on the power supply side to malfunction.

Therefore, when using a circuit breaker with a ground-fault circuit interrupter, select an appropriate one having an inoperative current value not smaller than the sum of the calculation results (a) and (b) to prevent malfunctioning due to leakage current.

- (a) Selection criterion per amplifier
Selection criterion: 2 mA per amplifier(*1)
- (b) Selection criterion per motor
Selection criterion: 1 mA per motor(*1)

The following example shows how to use selection criteria <1> and <2>:

Example:

When the system contains four βi SVM1 units

$$2 \text{ mA} \times 4 \text{ units (amplifiers)} + 1 \text{ mA} \times 4 \text{ (motors)} = 12 \text{ mA}$$

→ Select a circuit breaker with an inoperative current of 12 mA or more(*2).

(A general ground-fault circuit interrupt applicable to this example has a rated sensitivity current of 30 mA, and an inoperative current of 15 mA.)

NOTE

- 1 The above selection criteria are provided in order to select a circuit breaker with a ground-fault circuit interrupter, and do not express accurate leakage current values.
- 2 Depending on the frequency characteristic of the ground-fault circuit interrupter, the circuit breaker may malfunction. So, use a ground-fault circuit interrupter usable for inverter circuits.
- 3 The above selection criteria are values in the commercial frequency band. Some instruments measuring leakage current may detect a high frequency band and read larger values.

WARNING

Install a ground-fault circuit breaker.
To prevent fire and electric shock to a person, be sure to install a ground-fault circuit breaker (for inverter circuits).

6.3 NOISE PROTECTION

6.3.1 Separation of Signal Lines

If a power cable and signal cable run close to each other, noise can be induced. So, ensure that a power cable is separated from a signal cable. When a power cable and signal line cannot be separated from each other for a reason, minimize the distance by which the two cables run in parallel. When conduits are used, run a power cable through one conduit, and run a signal cable through another conduit.

Cable type		
Group	Signal	Action
A	Amplifier input power line	Separate these cables from those of group B by bundling them separately (Note 1) or by means of electromagnetic shielding (Note 2).
	Motor power line	
	Magnetic contactor drive coil (Note 3)	
B	Cable connecting the control unit and servo amplifier	Separate these cables from those of group A by bundling them separately (Note 1) or by means of electromagnetic shielding (Note 2). In addition, shielding must be provided.
	Sensor cable	
	Position coder cable	

NOTE

- 1 The bundle of group A cables must be separated from the bundle of group B cables by at least 10 cm.
- 2 Electromagnetic shielding involves shielding groups from each other by means of a grounded metal (steel) plate.
- 3 Attach a noise suppressor such as a spark killer to the magnetic contactor drive coil.

Cabinet

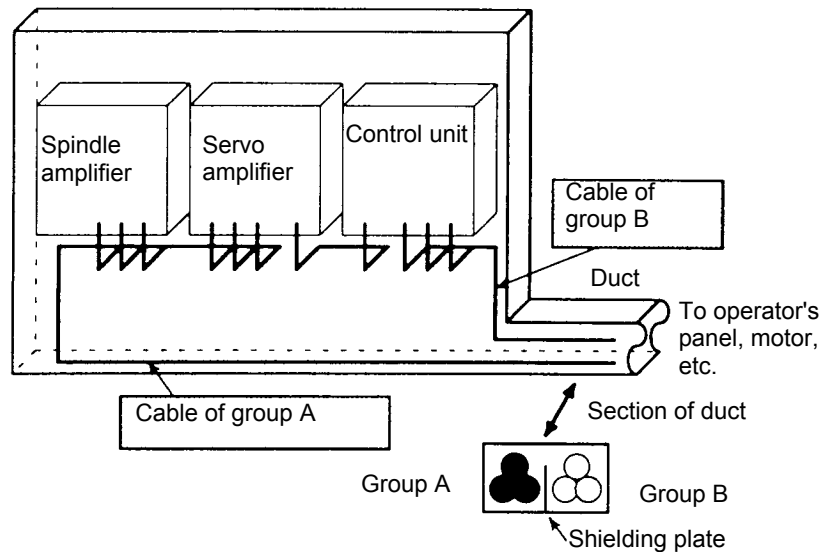

6.3.2 Grounding

A CNC machine tool has three separate ground systems:

- (1) Signal ground (SG) system
The signal ground (SG) system provides the reference potential (0V) for the electrical signal system.
- (2) Frame ground (FG) system
The frame ground (FG) system is provided to ensure safety and to shield external and internal noise. For example, the equipment frames, unit cases, panels, and interface cables connecting devices are all shielded.
- (3) System ground system
The system ground system is designed to connect each unit and the inter-unit frame ground system to ground.

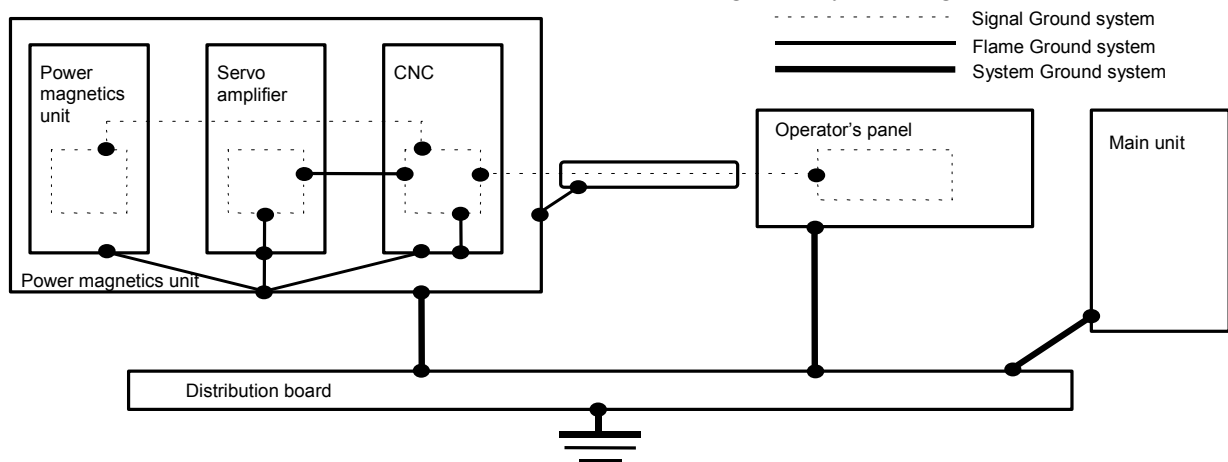

⚠ WARNING

[Warning on ground system wiring]

- 1 The ground resistance of the system ground must not exceed 100 Ω (class-3 ground).
- 2 System ground connection cables must have a sufficiently large cross-sectional area to enable them to safely carry the current that will arise in the event of a mishap such as a short-circuit. (In general, a cross-sectional area no less than that of the AC power line must be provided.)
- 3 The system ground connection cable shall be integrated with the AC power line, such that power cannot be supplied if the ground wire is disconnected.

6.3.3 Noise Suppressor

The AC/DC solenoid and relay are used in the power magnetics cabinet.

A high pulse voltage is caused by coil inductance when these devices are turned on or off.

This pulse voltage induced through the cable causes the electronic circuits to be disturbed. In general, to reduce this pulse voltage, a spark killer is used in AC circuits, while a diode is used in DC circuits.

Spark killer

- Use a spark killer consisting of a resistor and capacitor in series. This type of spark killer is called a CR spark killer. (Use it under AC)
(A varistor is useful in clamping the peak voltage of the pulse voltage, but cannot suppress the sudden rise of the pulse voltage. FANUC therefore recommends a CR spark killer.)
- The reference capacitance and resistance of the spark killer shall conform to the following based on the current (I(A)) and DC resistance of the stationary coil:

- Resistance (R) : Equivalent DC resistance of the coil
 - Capacitance (C) : $I^2/10$ to $I^2/20$ (μF)
- I : Current at stationary state of the coil (A)

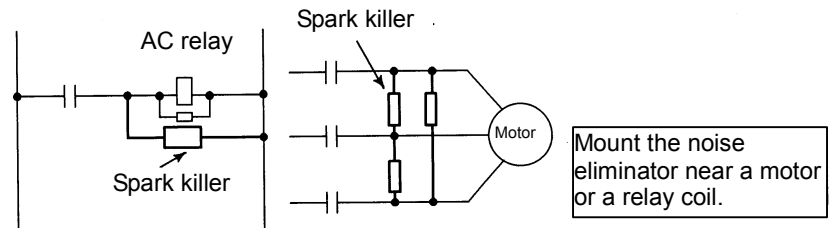
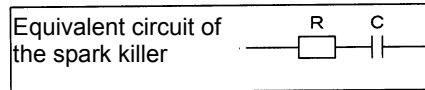

CAUTION
 Use a CR-type noise eliminator. Varistor-type noise eliminators clamp the peak pulse voltage but cannot suppress a sharp rising edge.

Diode

Diode (used for direct-current circuits)

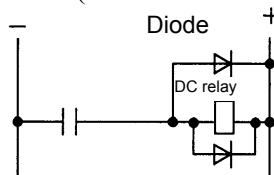

Use a diode which can withstand a voltage up to two times the applied voltage and a current up to two times the applied current.

6.3.4 Cable Clamp and Shield Processing

- Shield terminal processing
Process the terminal of the shield cover of a signal line according to Chapter 10, "DETAILS OF CABLE CONNECTION".
- Shield clamping
The amplifier cables that require shielding should be clamped by the method shown below. This cable clamp treatment is for both cable support and proper grounding of the shield. To insure stable CNC system operation, follow this cable clamp method. Partially peel out the sheath and expose the shield. Push and clamp by the plate metal fittings for clamp at the part.
- Installation of a ground plate
The user is to prepare a ground plate and install it according to Fig. 6.3.4(b) to (e).

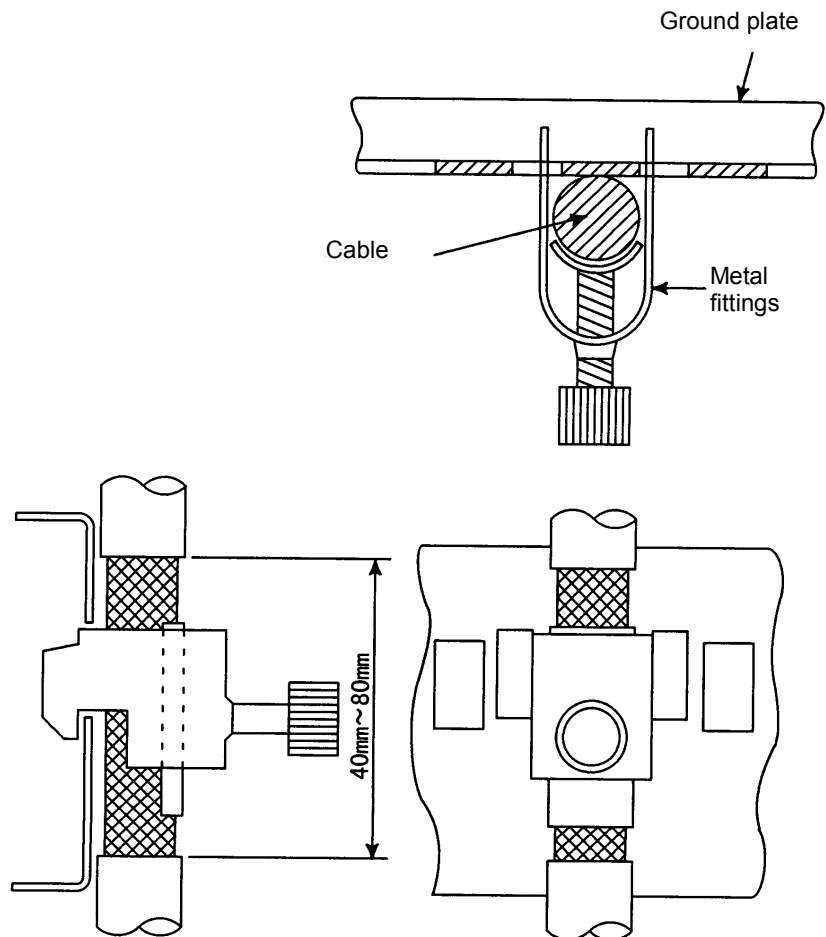

Fig.6.3.4(a) Cable clamp (1)

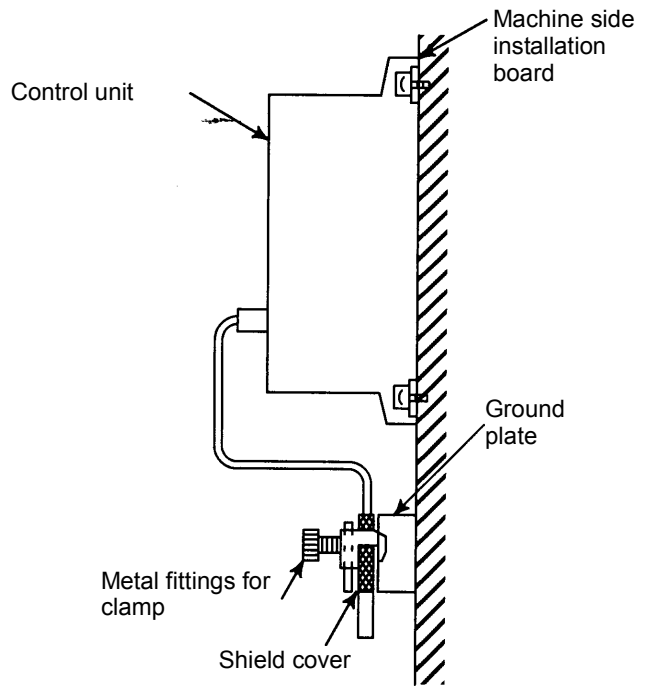

Fig.6.3.4(b) Cable clamp (2)

Prepare ground plate like the following figure.

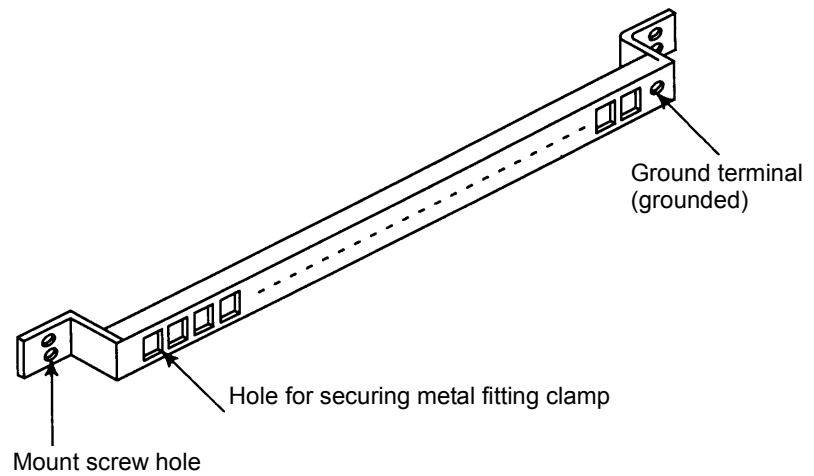

Fig.6.3.4(c) Ground plate

For the ground plate, use a metal plate of 2 mm or thicker, which surface is plated with nickel.

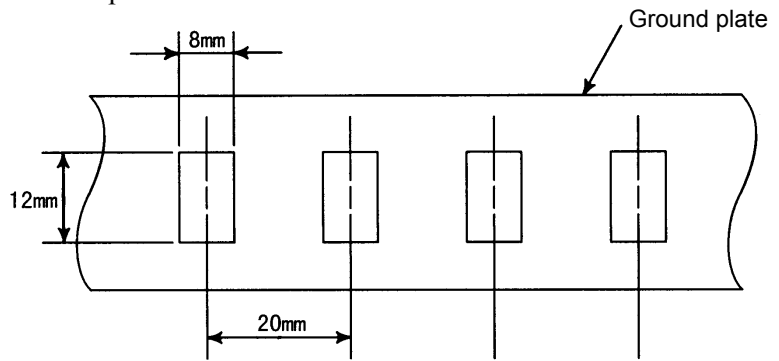

Fig.6.3.4(d) Ground plate holes

(Reference) Outer drawings of metal fittings for clamp.

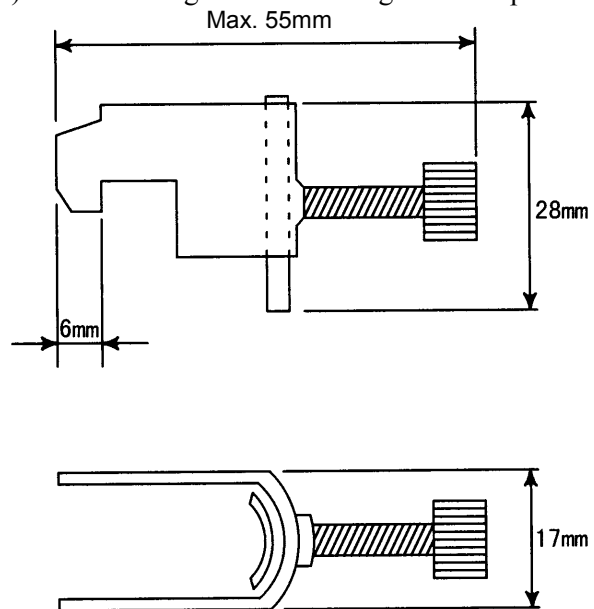

Fig.6.3.4(e) Outer drawings of metal fittings for clamp

Ordering specification for metal fittings for clamp

A02B-0214-K001 (2 pieces)

6.4 INSTALLING LIGHTNING SURGE ABSORBERS

At the power input of the power magnetics cabinet, install a surge absorber between the power lines and between each power line and a ground to protect the unit from a voltage surge caused by lightning. How to install the surge absorber is shown below.

(1) Surge absorber for three-phase input

When using an integrated lightning surge absorber between the power lines and between each power line and a ground

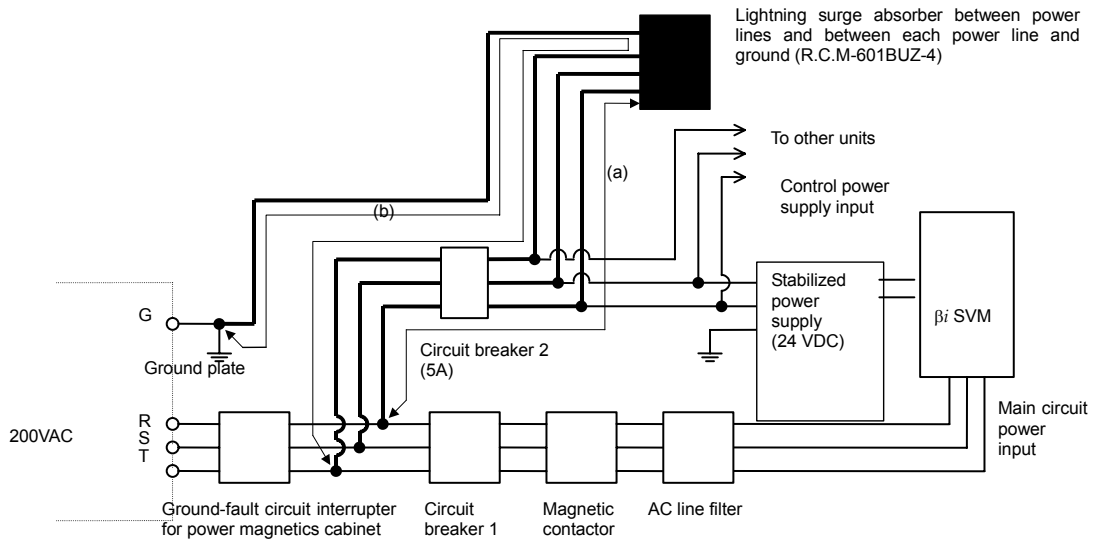

When using separate lightning surge absorbers between the power lines and between each power line and a ground

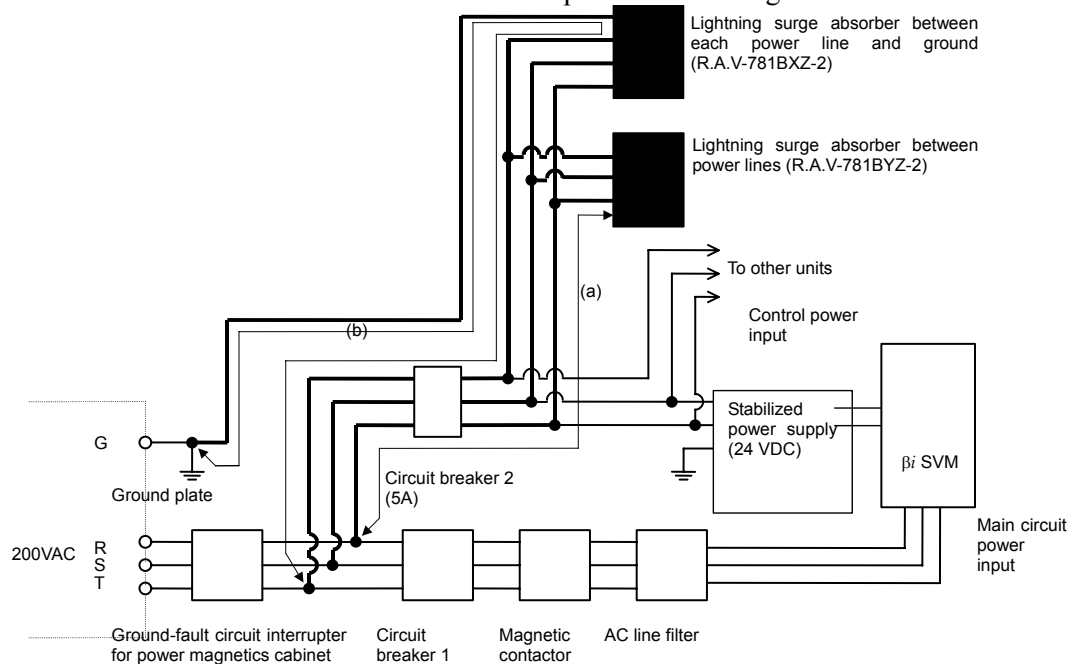

- (2) Surge absorber for single-phase input
 When using an integrated lightning surge absorber between the power lines and between each power line and a ground

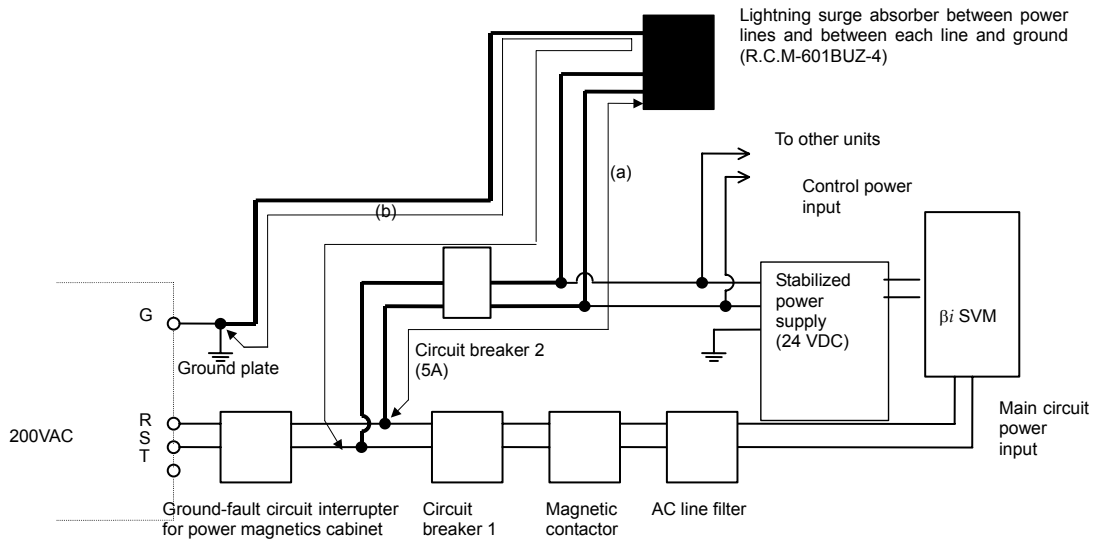

- When using separate lightning surge absorbers between the power lines and between each power line and a ground

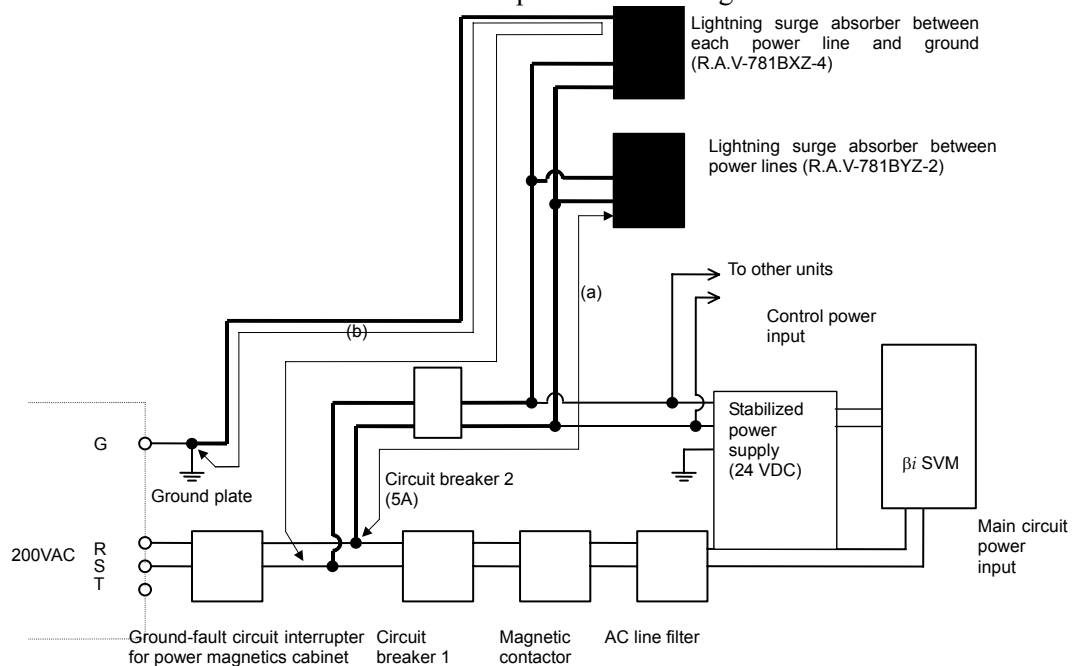

(3) Surge absorber for three-phase input

⚠ WARNING

- 1 Make the wires shown with thick line in the above diagram as short as possible in order to increase the effect of the lightning surge absorber.
Wire Cross section : At least 2mm²
Length : Keep the total wire length (a+b) to within 2m, where a = length of wire used to connect lightning surge absorber (1) b = length of wire used to connect lightning surge absorber (2)
- 2 When performing a dielectric strength test by applying an overvoltage (such as 1000 or 1500 VAC) to a power line, remove lightning surge absorber (2) so that it will not operate.
- 3 The circuit protector (5A) is intended to protect the lines if a lightning surge absorber is damaged due to a surge that is higher than the maximum allowable voltage of the surge absorber.
- 4 Usually, no current flows through the lightning surge absorbers. So the circuit protector (5A) may be used also for other sections (such as power supply module control power and spindle motor fan power).

The following table lists commercially available lightning surge absorbers.

Table 6.4(a) Lightning surge absorbers (not complying with the relevant standards)

Lightning surge absorber	Manufacturer's specification Okaya Electric Industries	Clamp voltage [V]±10%	Maximum allowable surge current 8/20µsec [A]	Maximum allowable surge voltage 1.2/50µsec [V]	Maximum allowable circuit voltage [Vrms]
<1>	R·A·V-781BYZ-2	783	1000	12000	300
<2>	R·A·V-781BXZ-2A	783	1000	12000	300

Table 6.4(b) Lightning surge absorbers (complying with the relevant standards)

Lightning surge absorber	Manufacturer's specification Okaya Electric Industries	Clamp voltage [V]±10%	Maximum allowable surge current 8/20µsec [A]	Maximum allowable surge voltage 1.2/50µsec [V]	Maximum allowable circuit voltage [Vrms]
<1>	R·A·V-781BYZ-2	783	1000	12000	300
<2>	R·A·V-781BXZ-4	783	1000	12000	300

7

PROTECTIVE GROUNDING

7.1 SVM1-4i and SVM1-20i (FSSB Interface)

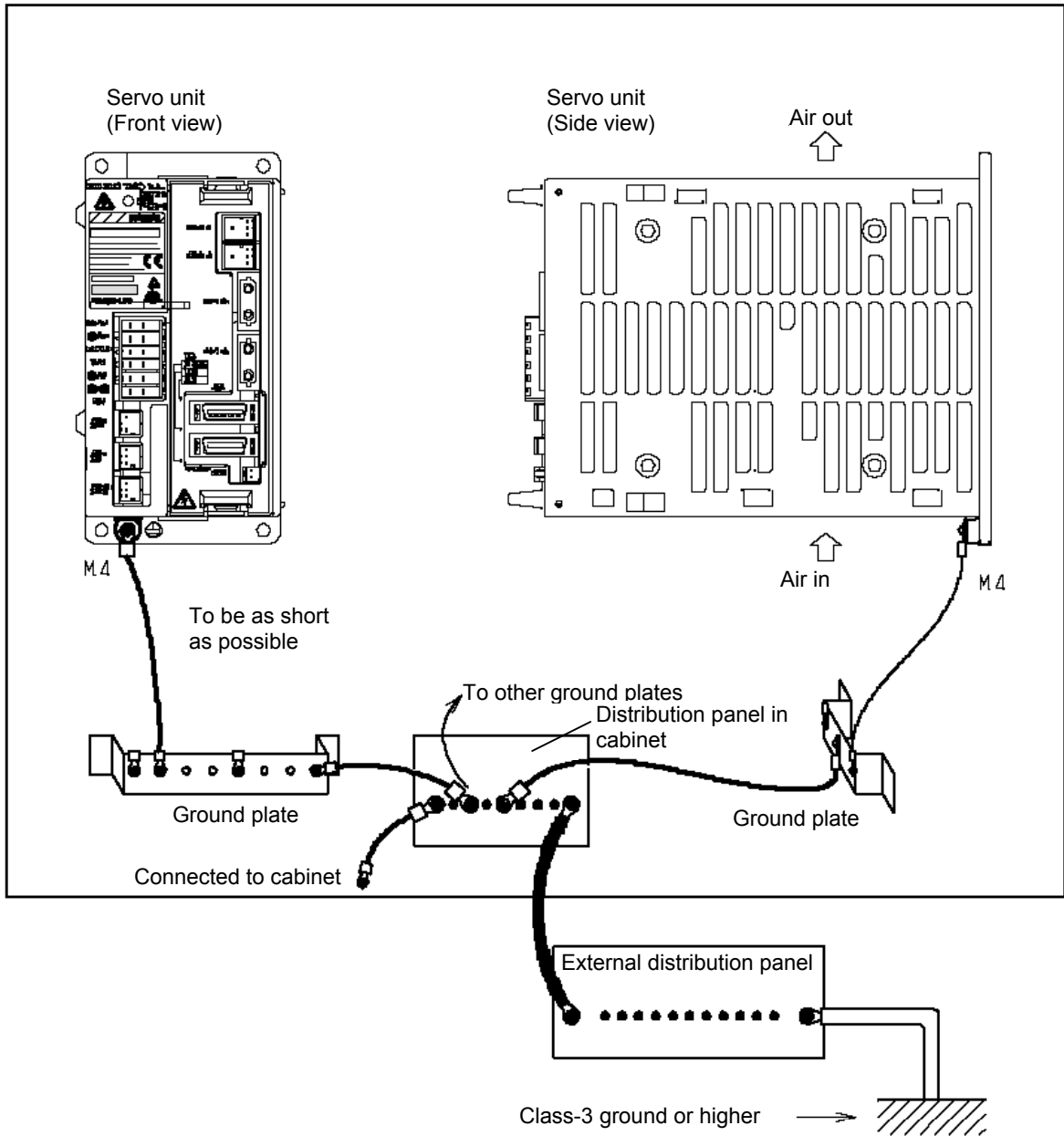

7.2 SVM1-40i and SVM1-80i (FSSB Interface)

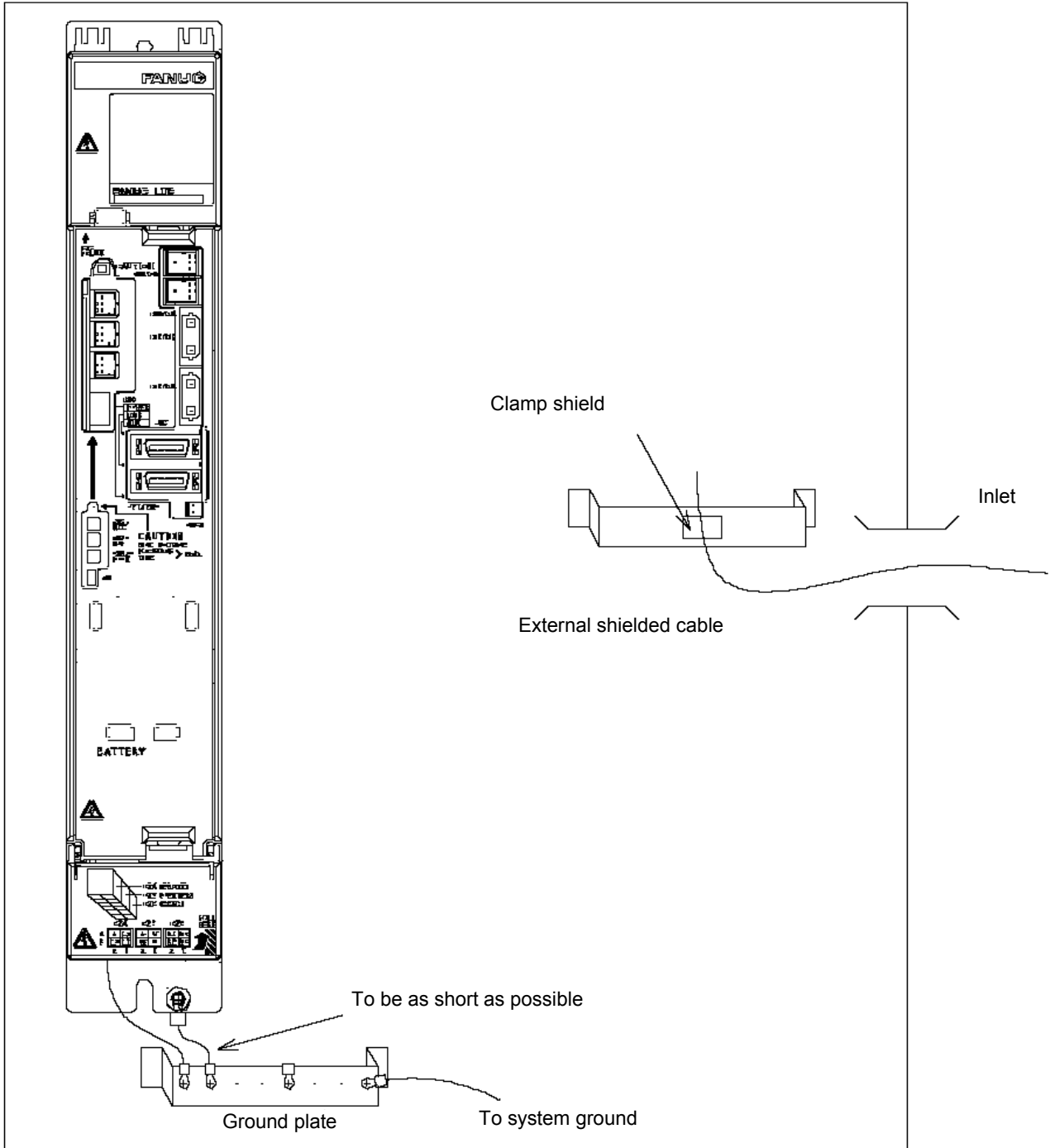

8

EXTERNAL DIMENSIONS / PANEL CUT-OUT DRAWINGS / MAINTENANCE AREA

8.1 EXTERNAL DIMENSIONS

8.1.1 External Dimensions of SVM1-4i and SVM1-20i

Amplifier alone

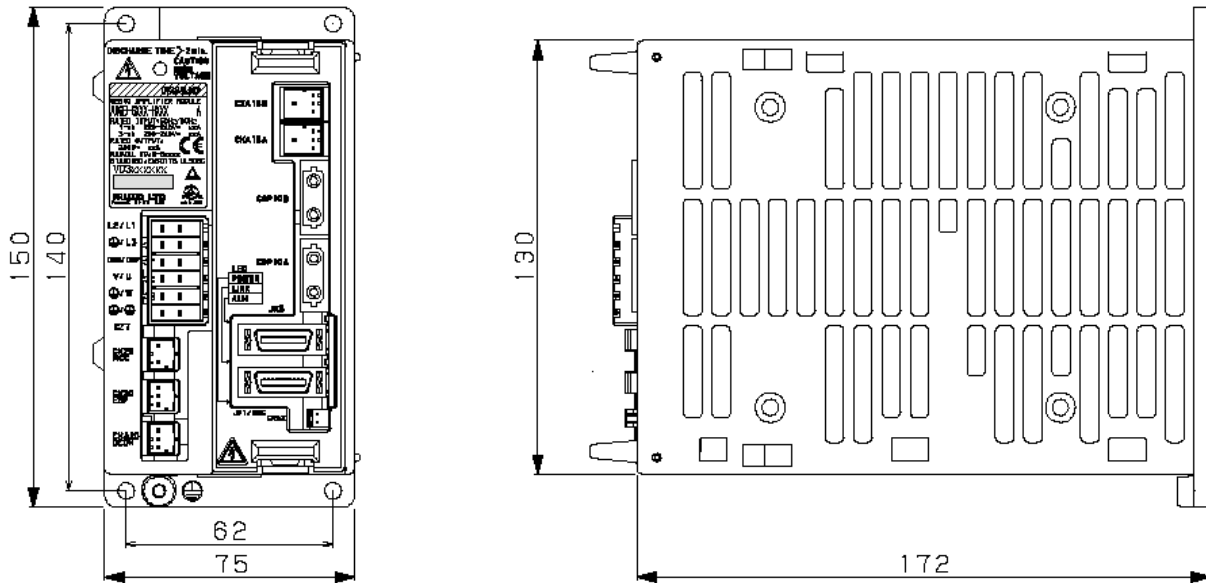

Weight : 1.2kg

Amplifier with a regenerative resistor, fan motor, and battery attached

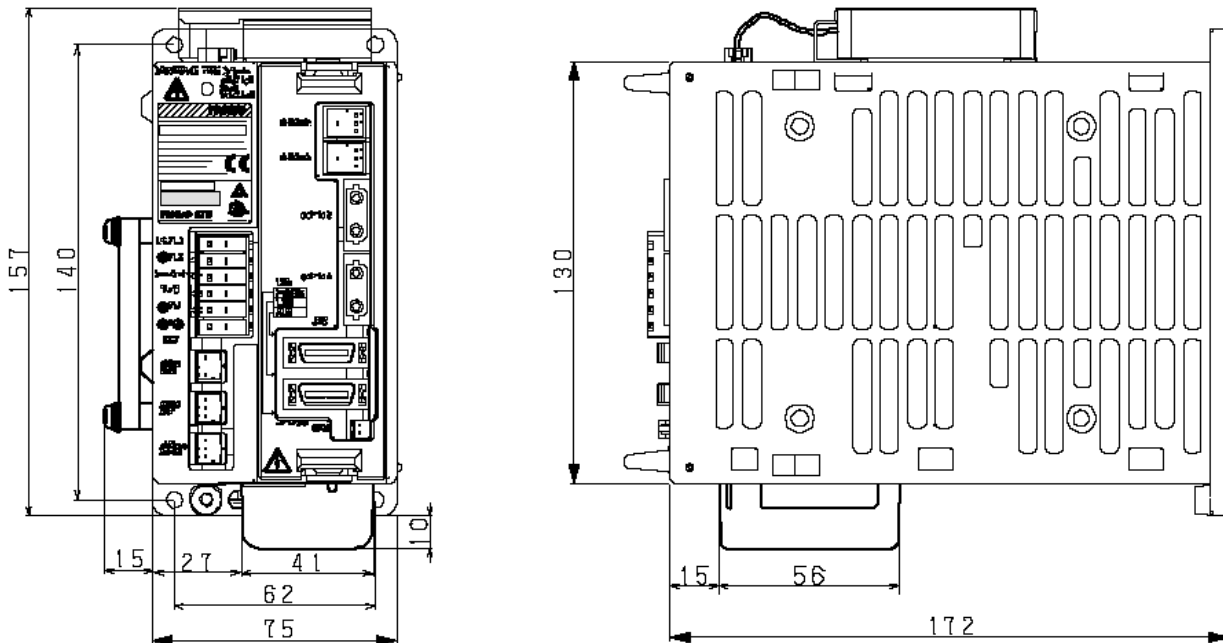

Weight : 1.3kg

8.1.2 External Dimensions of SVM1-40i and SVM1-80i

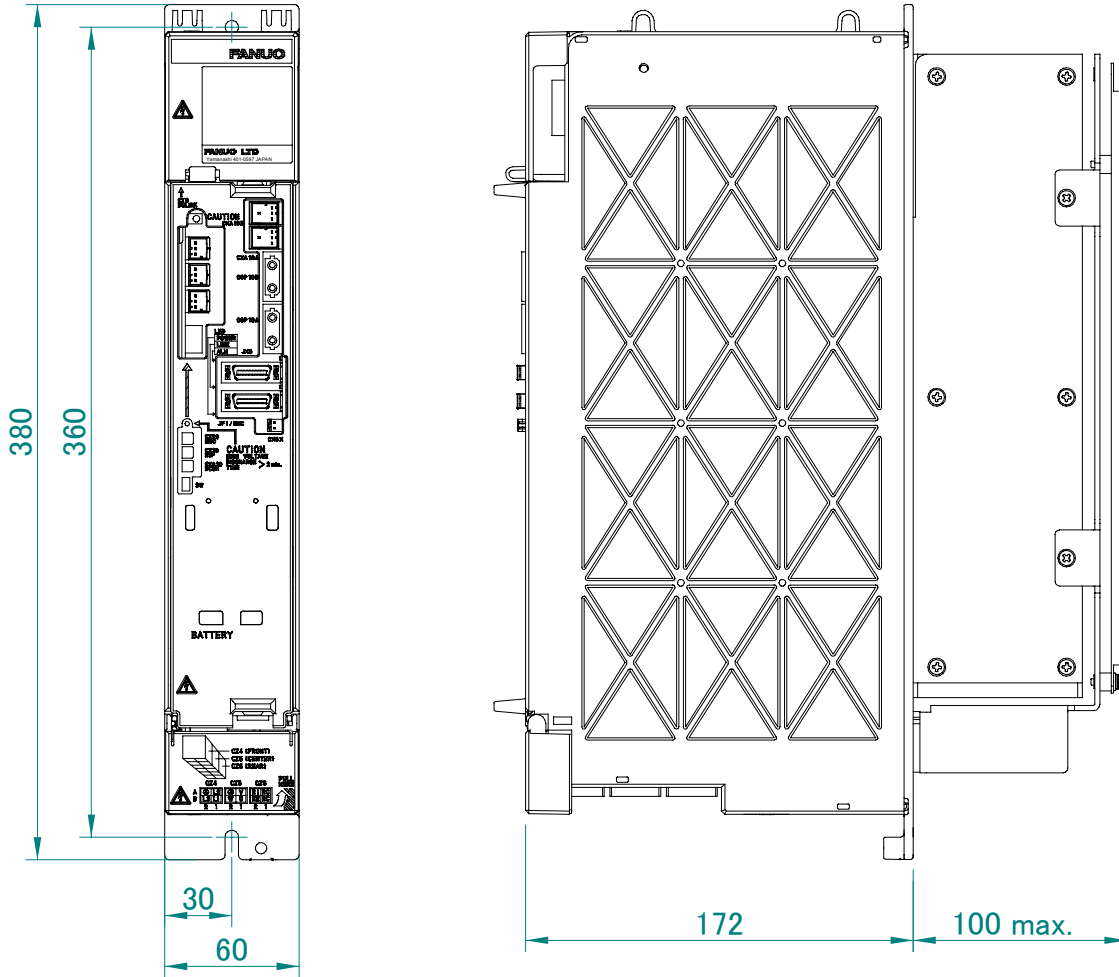

Weight : 3.9kg

8.1.3 External Dimensions of Fan Unit (A06B-6134-K003)

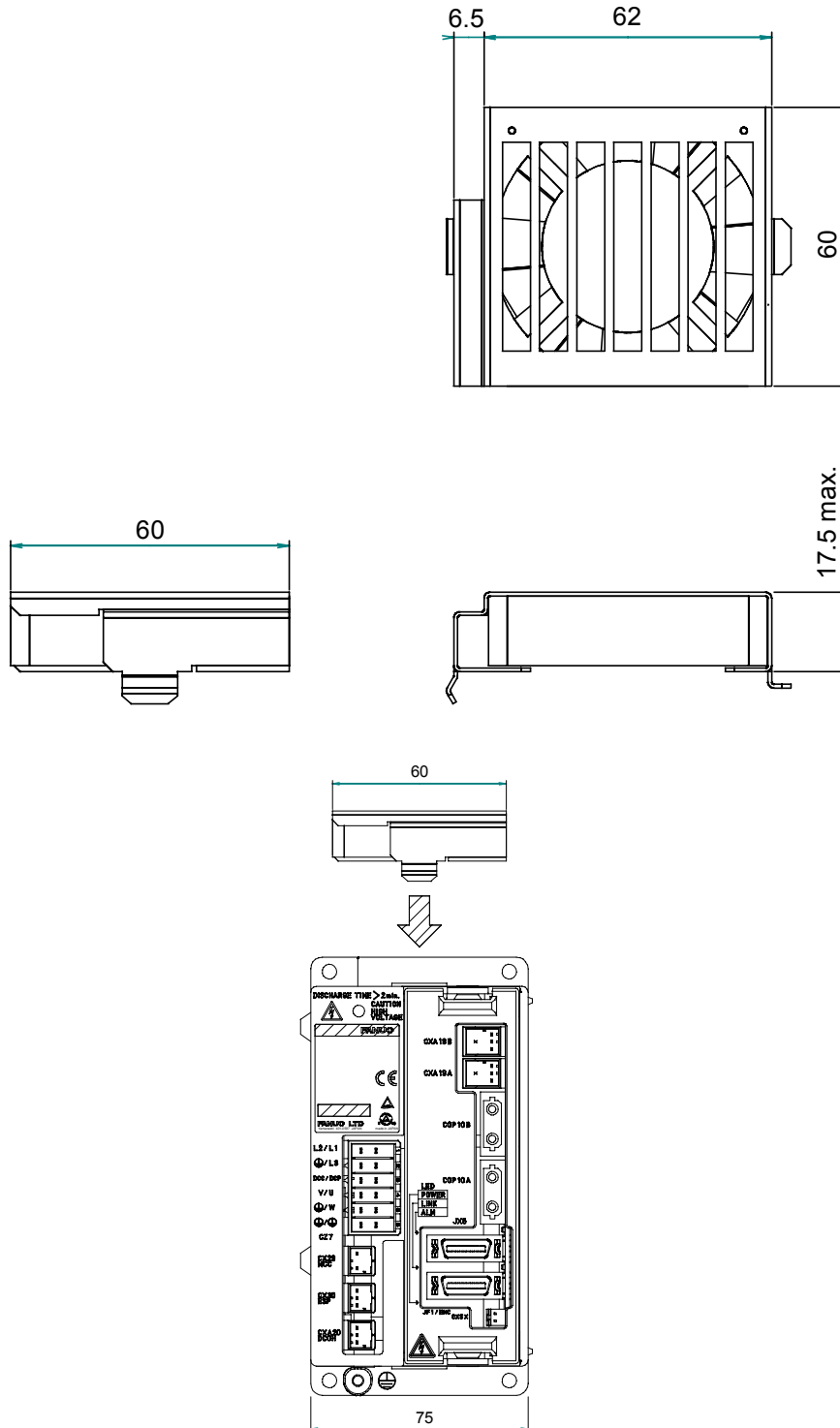

8.1.4 External Dimensions of Fan Unit (A06B-6134-K002)

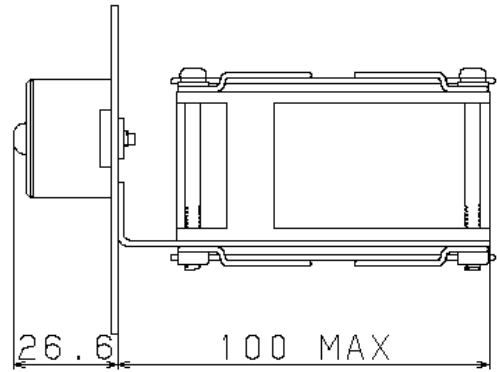
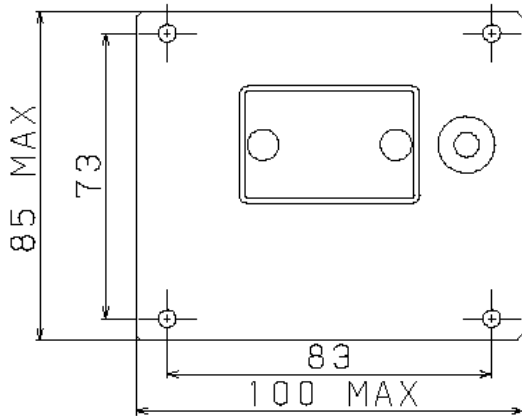
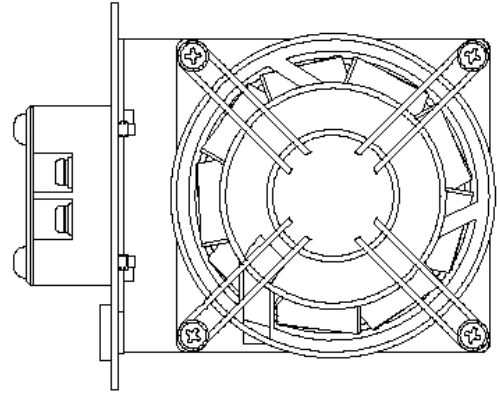

8.1.5 Discharge Resistor

A06B-6130-H401

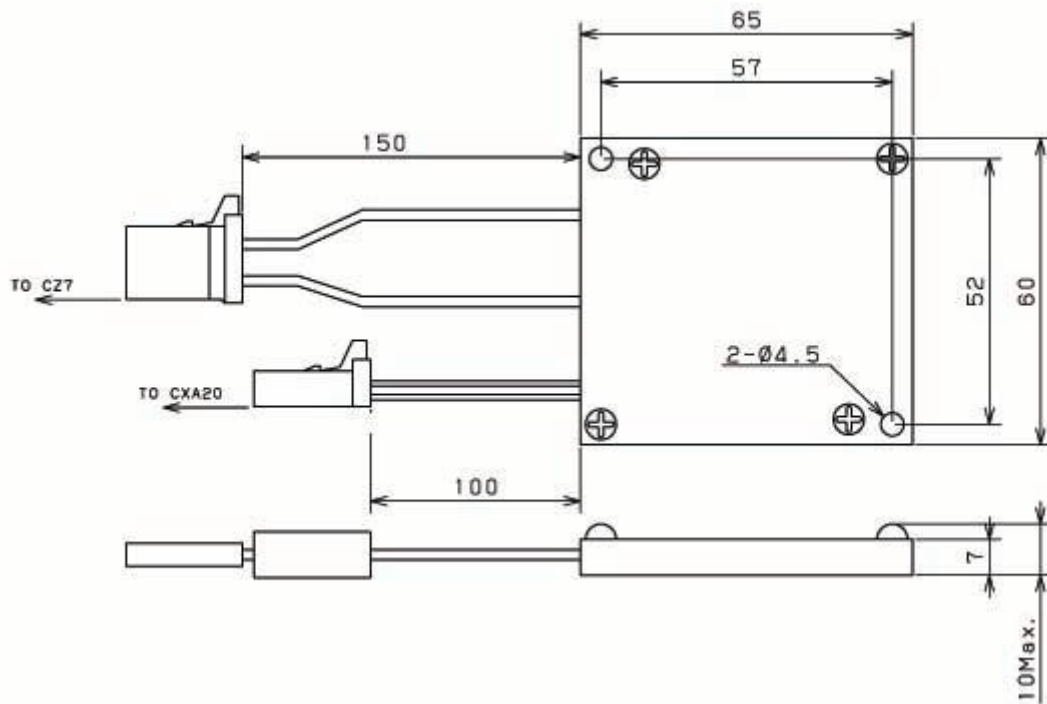

Weight: 0.07 kg

A06B-6130-H402

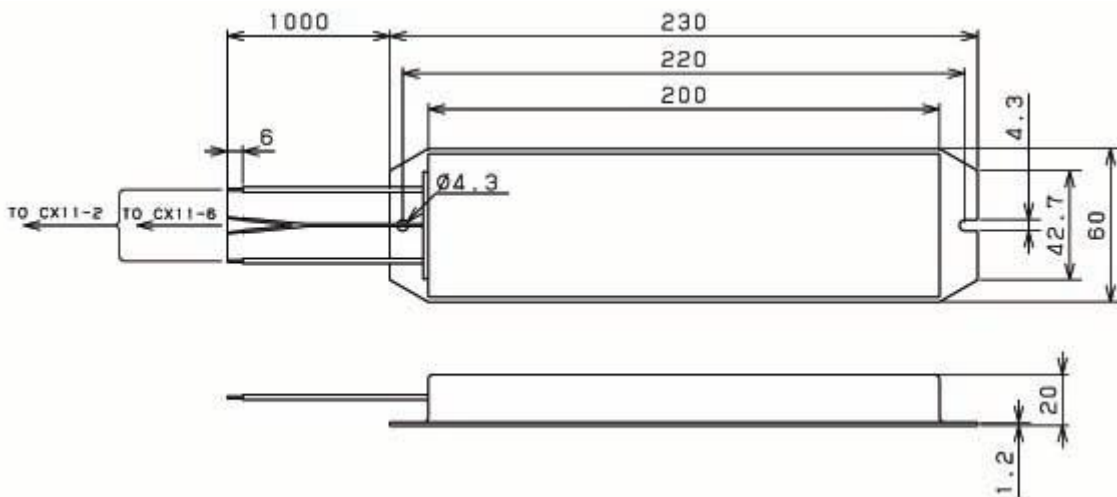

Weight: 0.5 kg

A06B-6089-H500

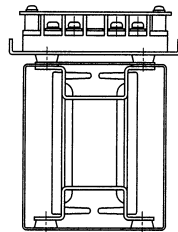
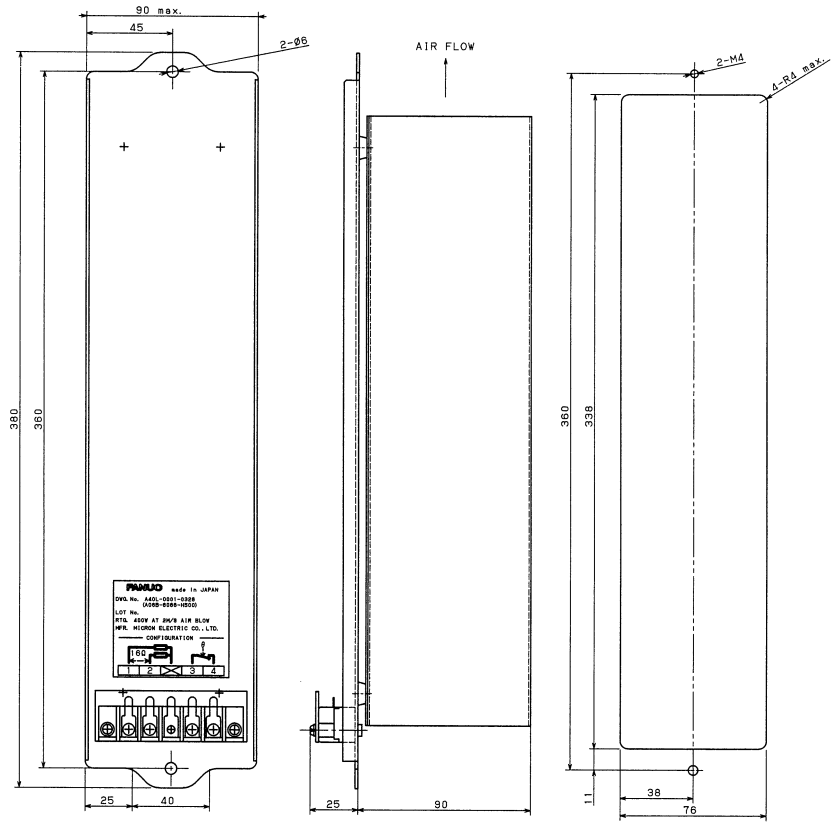

パネルカット図
PANEL CUT-OUT

抵抗値: 16Ω (80X2)
RESISTANCE
端子台: M4X4
TERMINAL BLOCK: M4x4
質量: 2.2kg
WEIGHT: 2.2kg

A06B-6089-H713 to H714

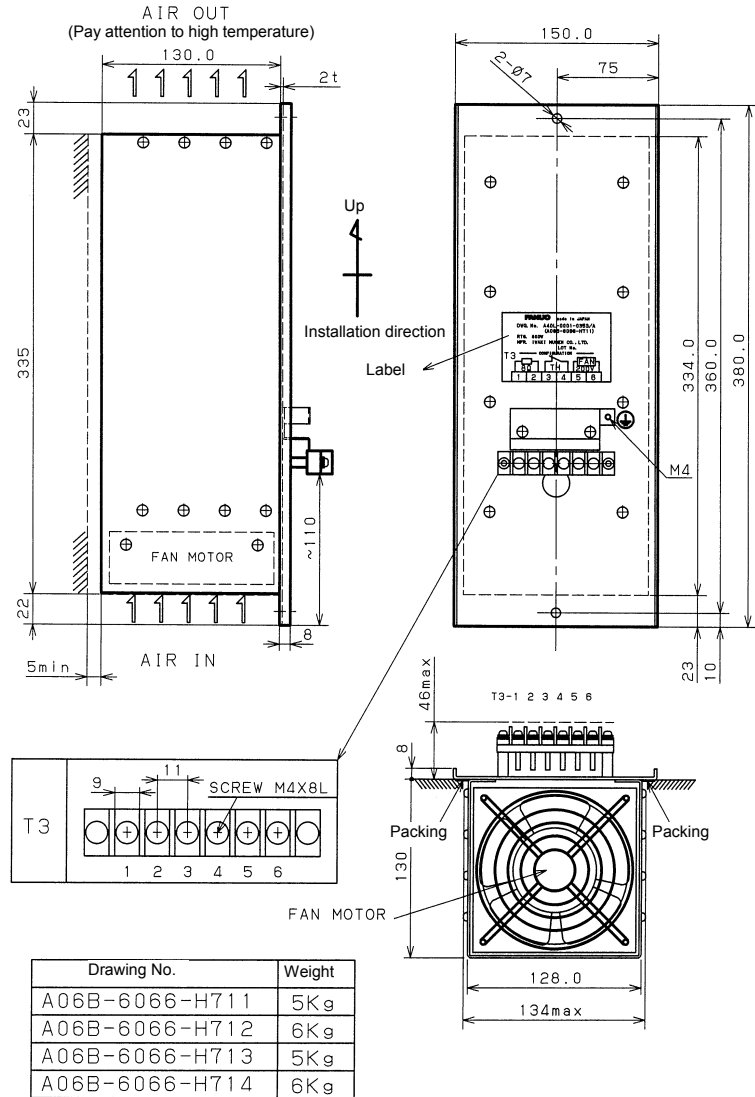

8.1.6 AC Line Filter

A81L-0001-0083#3C

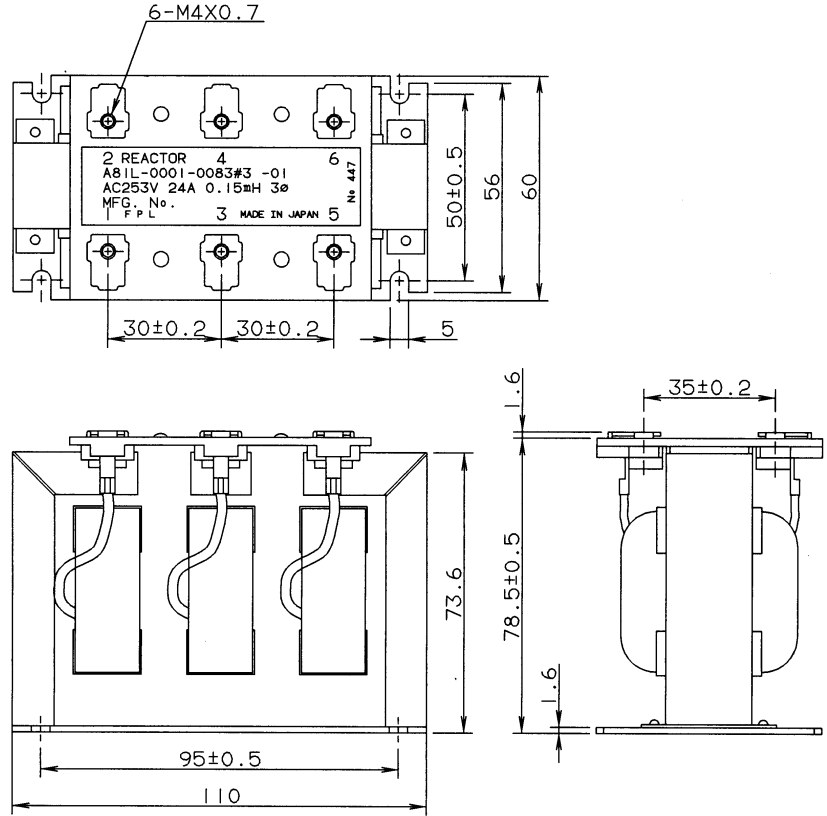

A81L-0001-0101#C

A81L-0001-0101#C

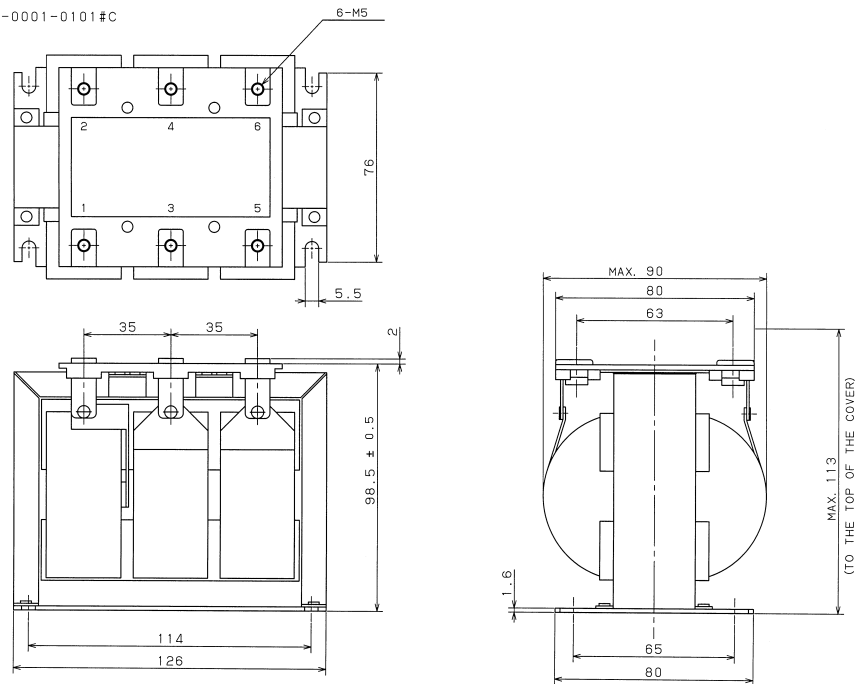

A81L-0001-0102

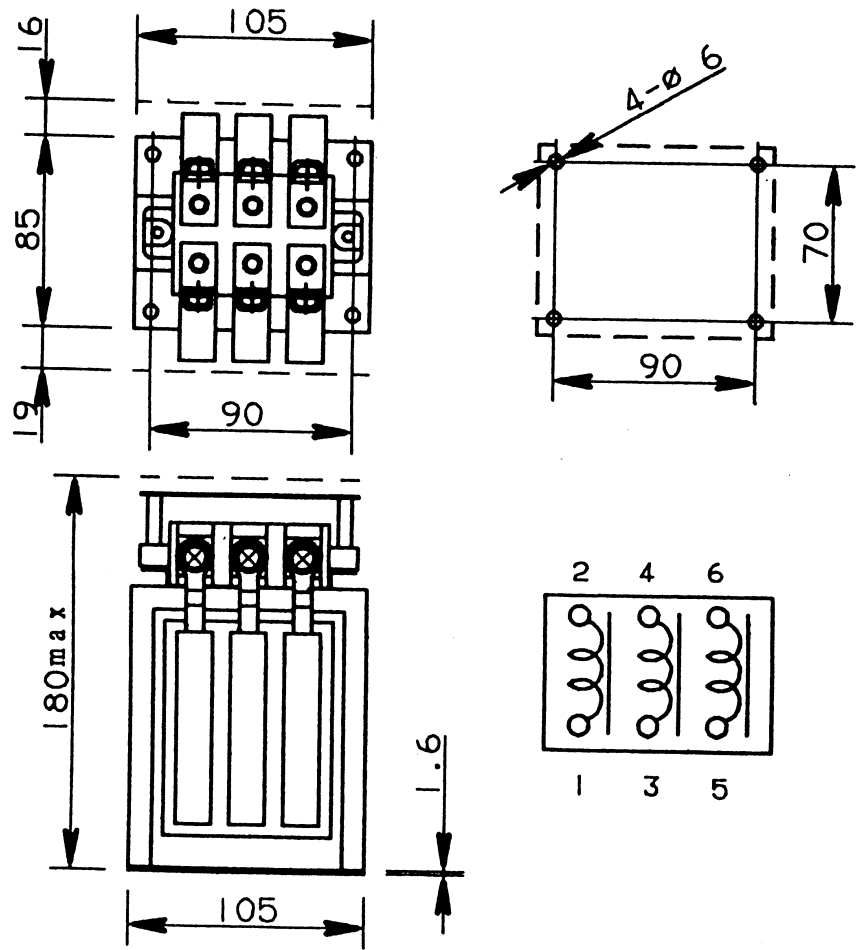

8.1.7 Transformer for Exports

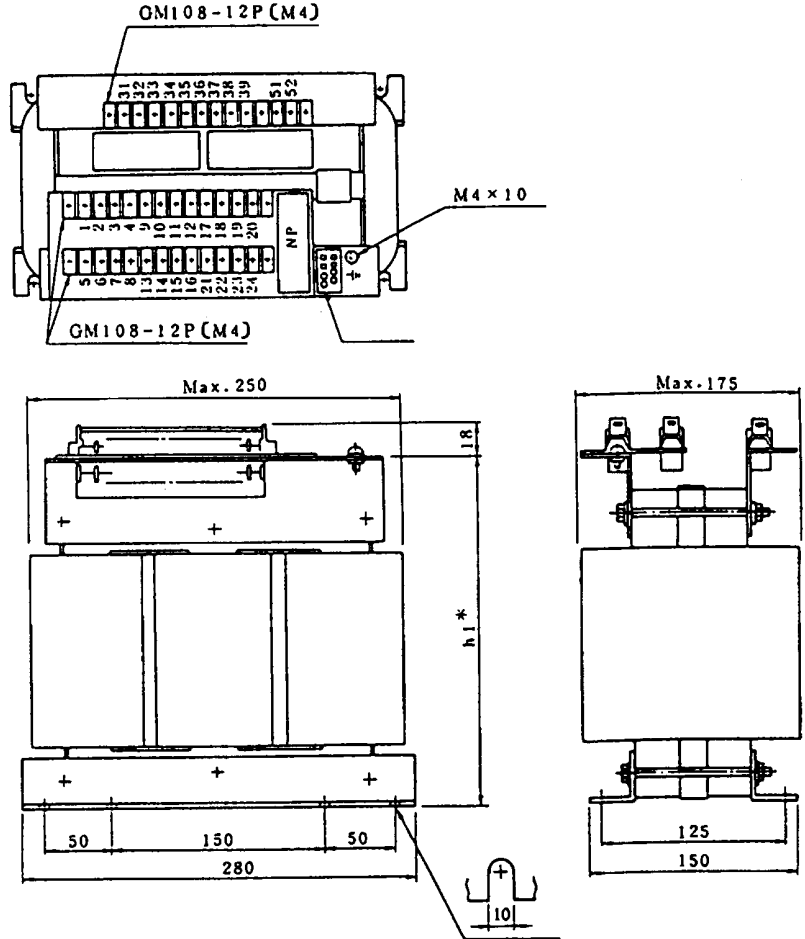

Drawing No.	A80L-0022-0005	A80L-0024-0006	A80L-0026-0003	A80L-0028-0001
Type (name)	SAE	SBE	SCE	SDE
Weight	21 kg	27 kg	36 kg	42 kg
h1* (transformer height)	217 mm max	217 mm max	247 mm max	247 mm max

8.1.8 Battery Case

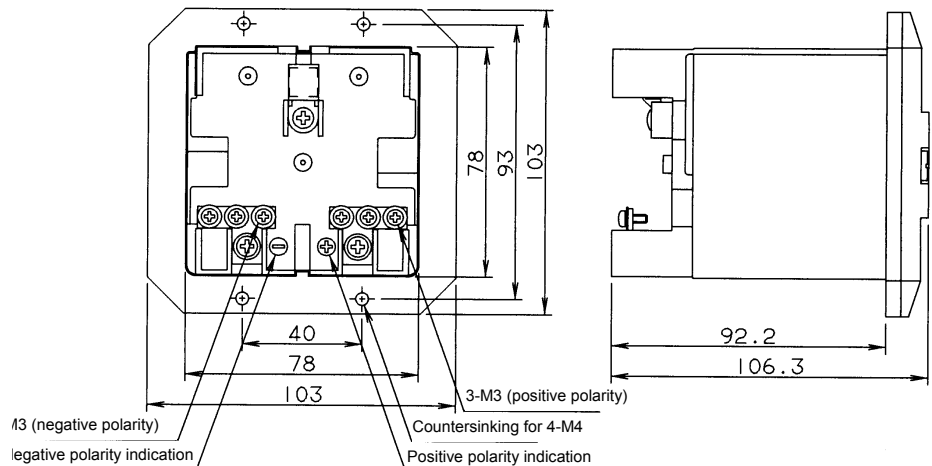

8.1.9 Lightning Surge Absorbers

(a) A06B-6077-K142

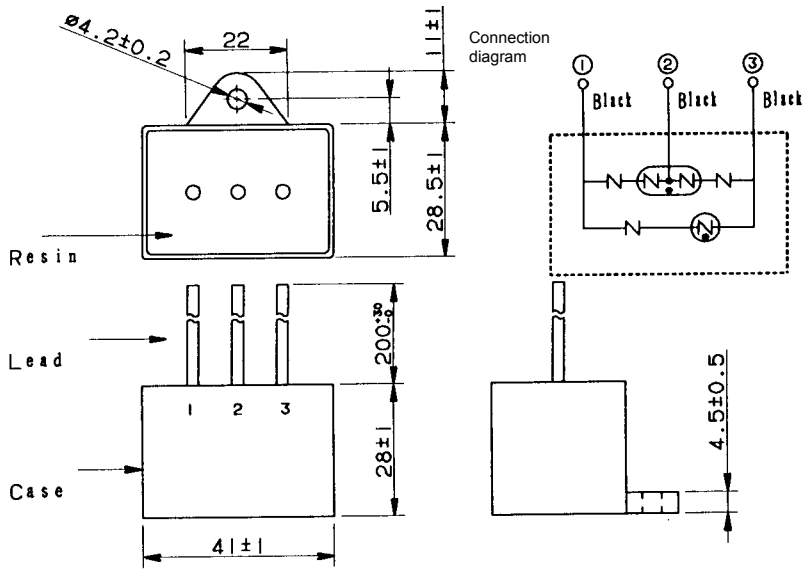

(1) Between power lines:
RAV-781BYZ-2

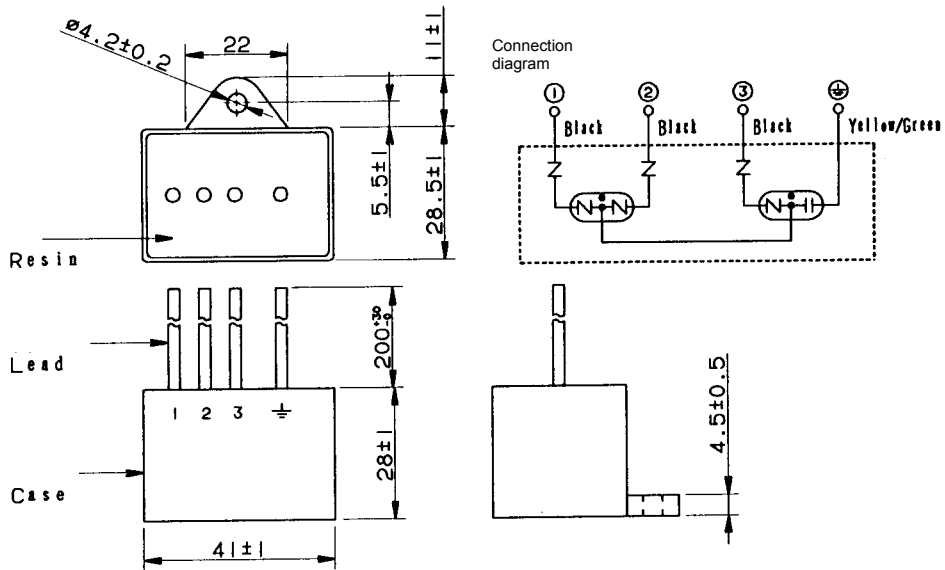

(2) Between each power line and ground: RAV-781BXZ-4

Specification	Rated voltage	Clamp voltage	Withstanding surge current	Withstanding surge voltage
R-A-V-781BYZ-2	250 VAC	783 VDC±10%(V1.0)	2500A(8/20µS)	20kV(1.2/50µS)

Specification	Rated voltage	AC discharge start voltage	Withstanding surge current	Maximum surge discharge start voltage
R-A-V-781BXZ-4	430 VAC between lines, 250 VAC between each line and ground	700 VAC±20%(Ua)	2500A(8/20µS)	2.0kV(1.2/50µS)

(b)A06B-6077-K144

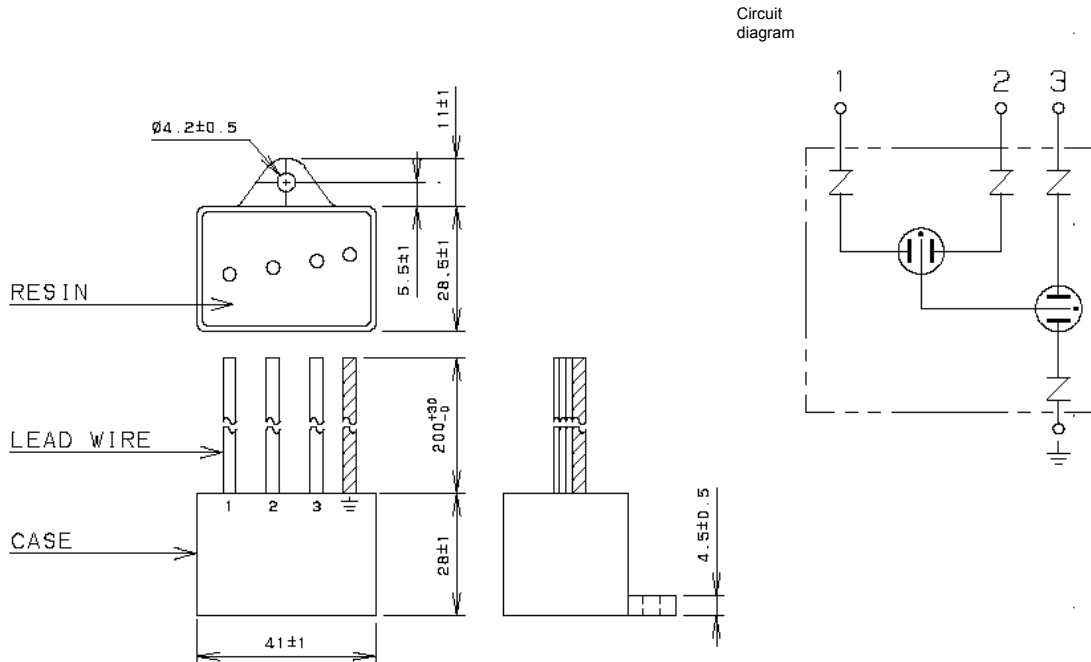

Specification	Rated voltage	AC discharge start voltage	Clamp voltage	Withstanding surge current	Withstanding surge voltage	Maximum surge discharge start voltage
R-C-M-601BUZ-4	250 VAC	560 VAC $\pm 20\%(U_a)$	2000V $\pm 10\%(V_{1.0})$	2500A (8/20 μ S)	20kV (1.2/50 μ S)	2kV (1.2/50 μ S)

8.2 PANEL CUT-OUT DRAWINGS

8.2.1 SVM1-4i and SVM1-20i

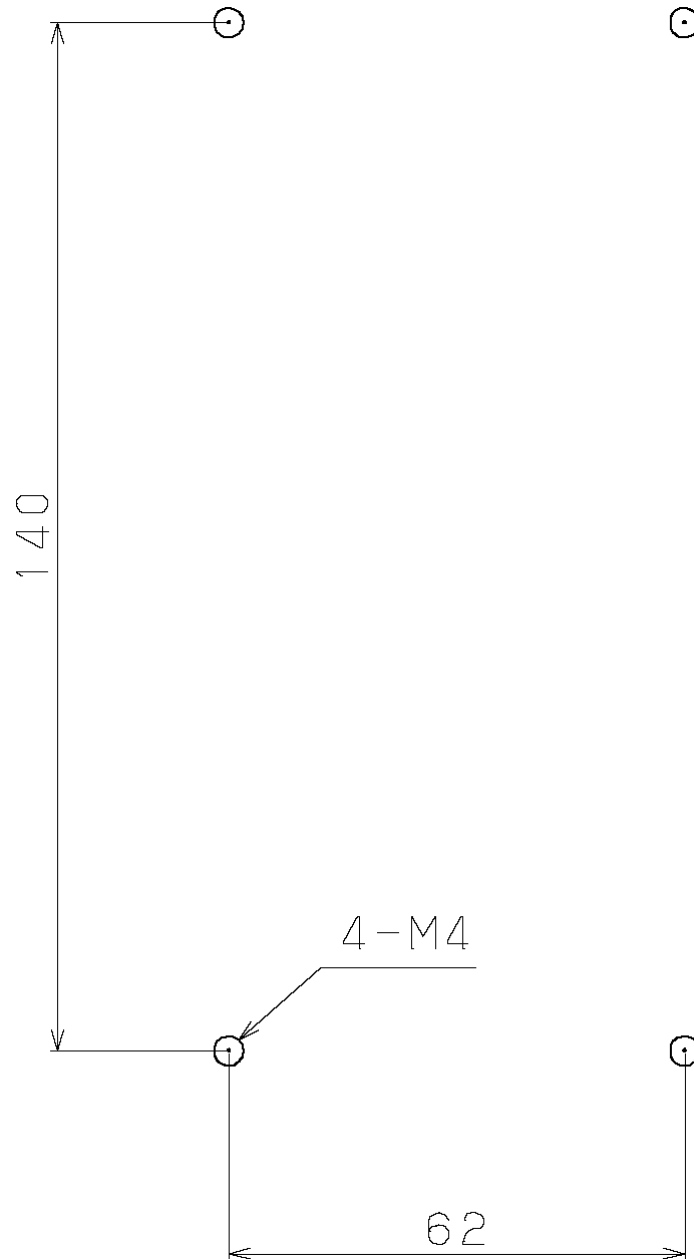

8.2.2 SVM1-40i and SVM1-80i

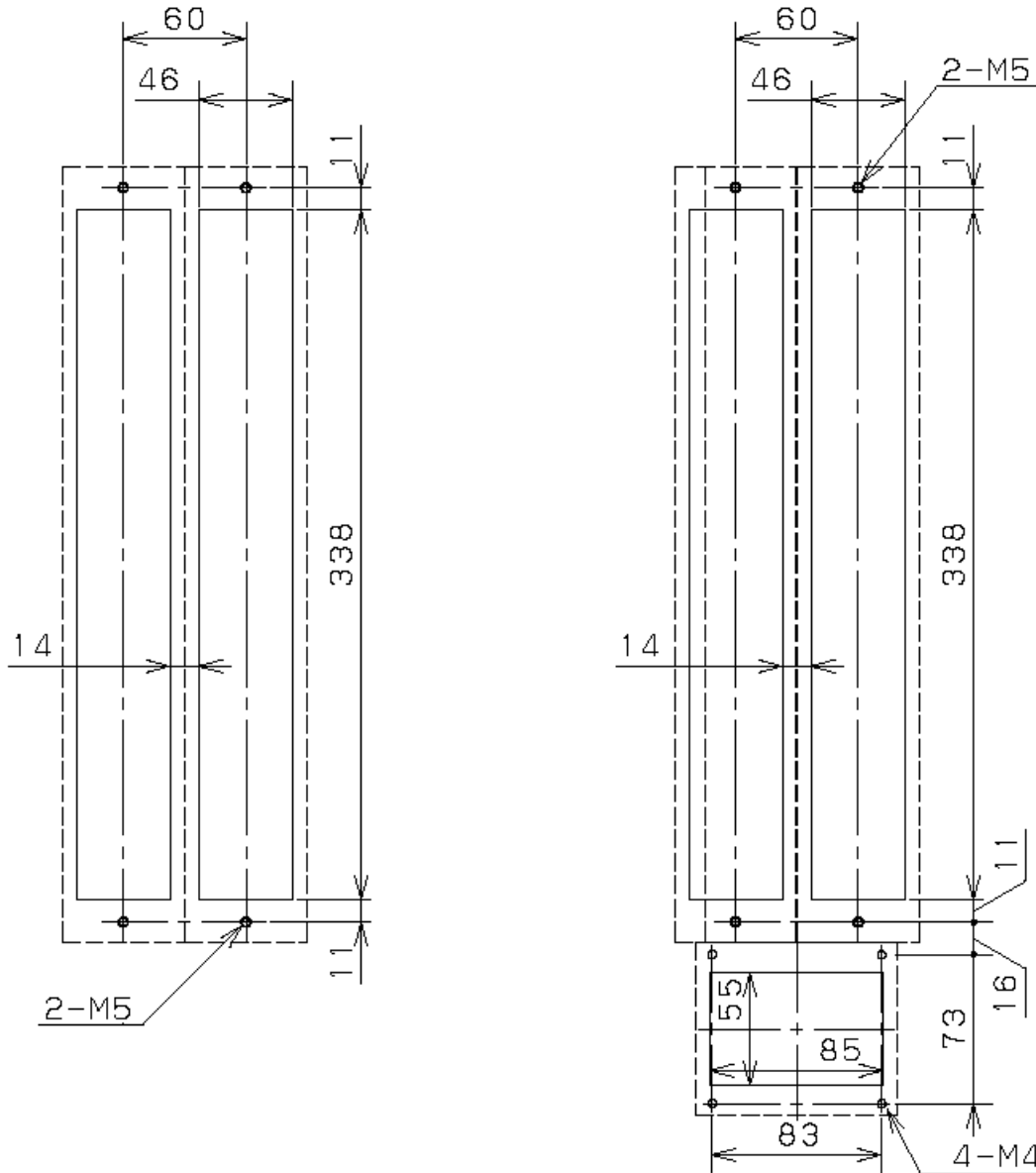

NOTE

Attach the accompanying gasket around the panel cut-out to prevent oil and dust from getting into it. Reinforce the right and left sides of the panel cut-out in the power magnetics cabinet by using fittings such as angles to maintain satisfactory contact between the power magnetics cabinet and the amplifier.

8.2.3 Discharge Resistor

A06B-6089-H500

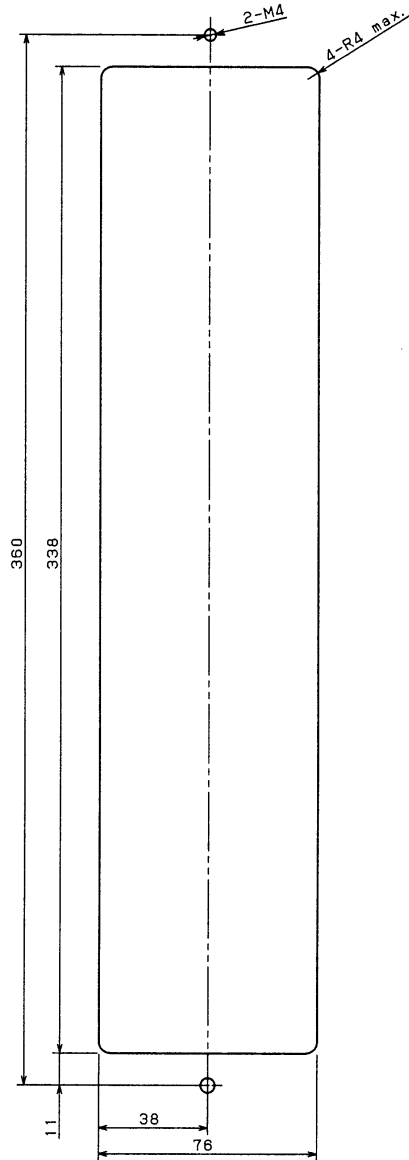

PANEL CUT-OUT



CAUTION

Attach the packing (acrylonitrile-butadiene rubber, NBR (soft type)) to prevent oil and dust from getting into the resistor.

A06B-6089-H713 to H714

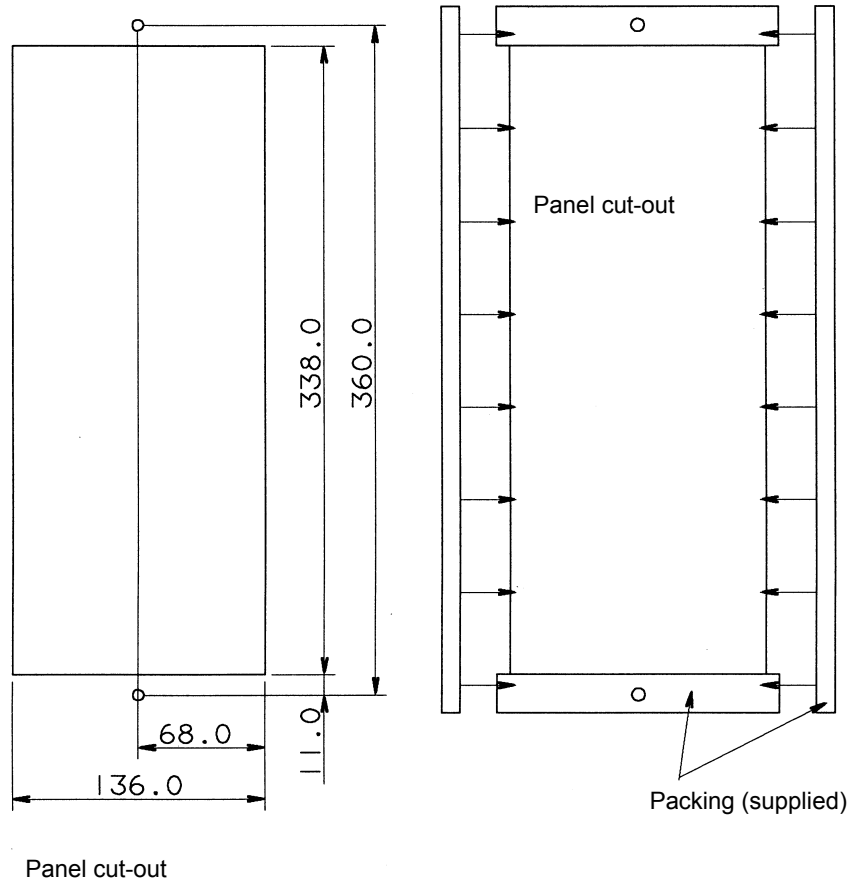

⚠ CAUTION
Attach the packing (acrylonitrile-butadiene rubber, NBR (soft type)) to prevent oil and dust from getting into the resistor.

8.3 MAINTENANCE AREA

8.3.1 Maintenance Area for the SVM1-4i and SVM1-20i

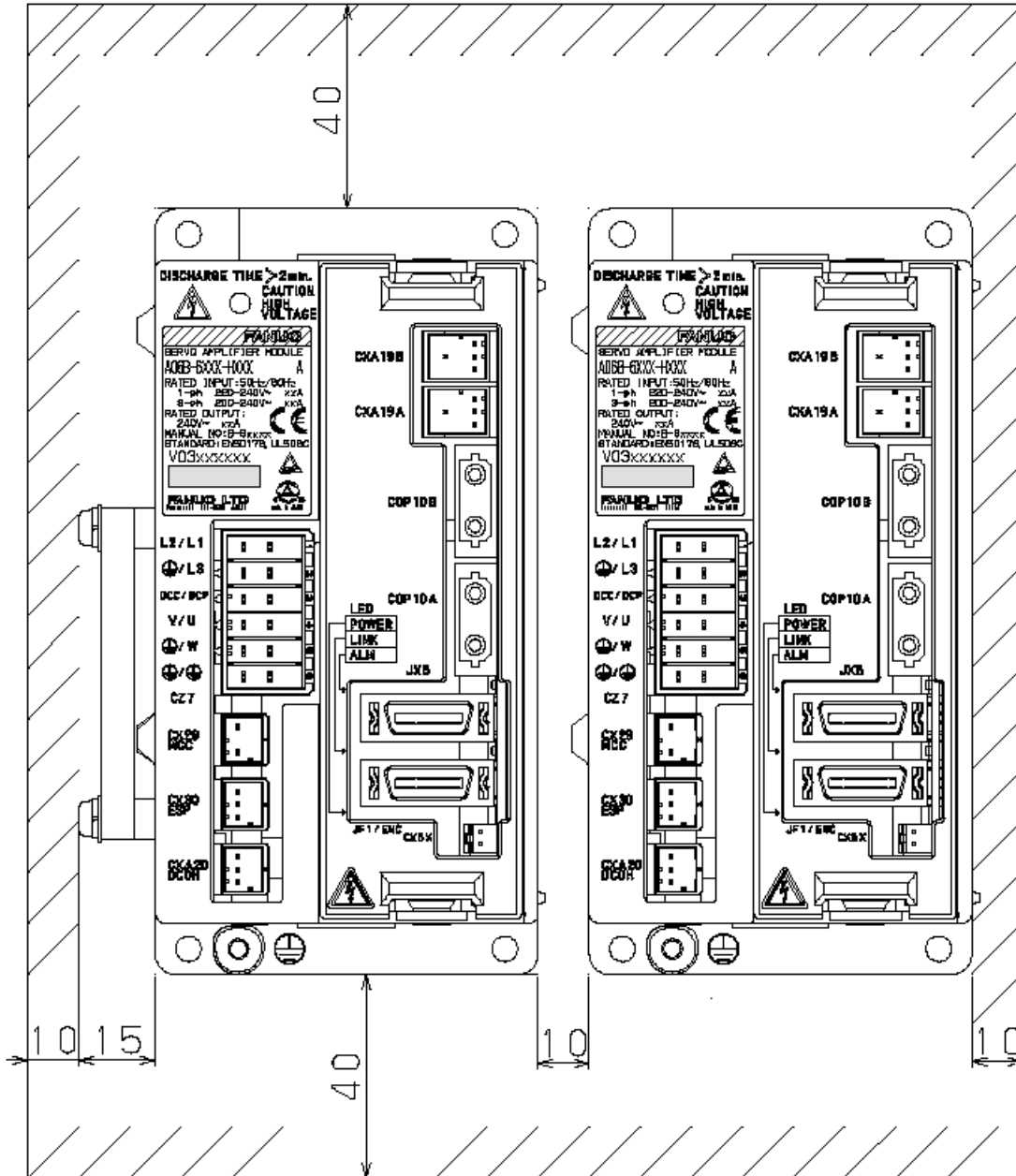

8.3.2 Maintenance Area for the SVM1-40i and SVM1-80i

When no cooling fan AC motor (A06B-6134-K002) is used to cool the heat sink

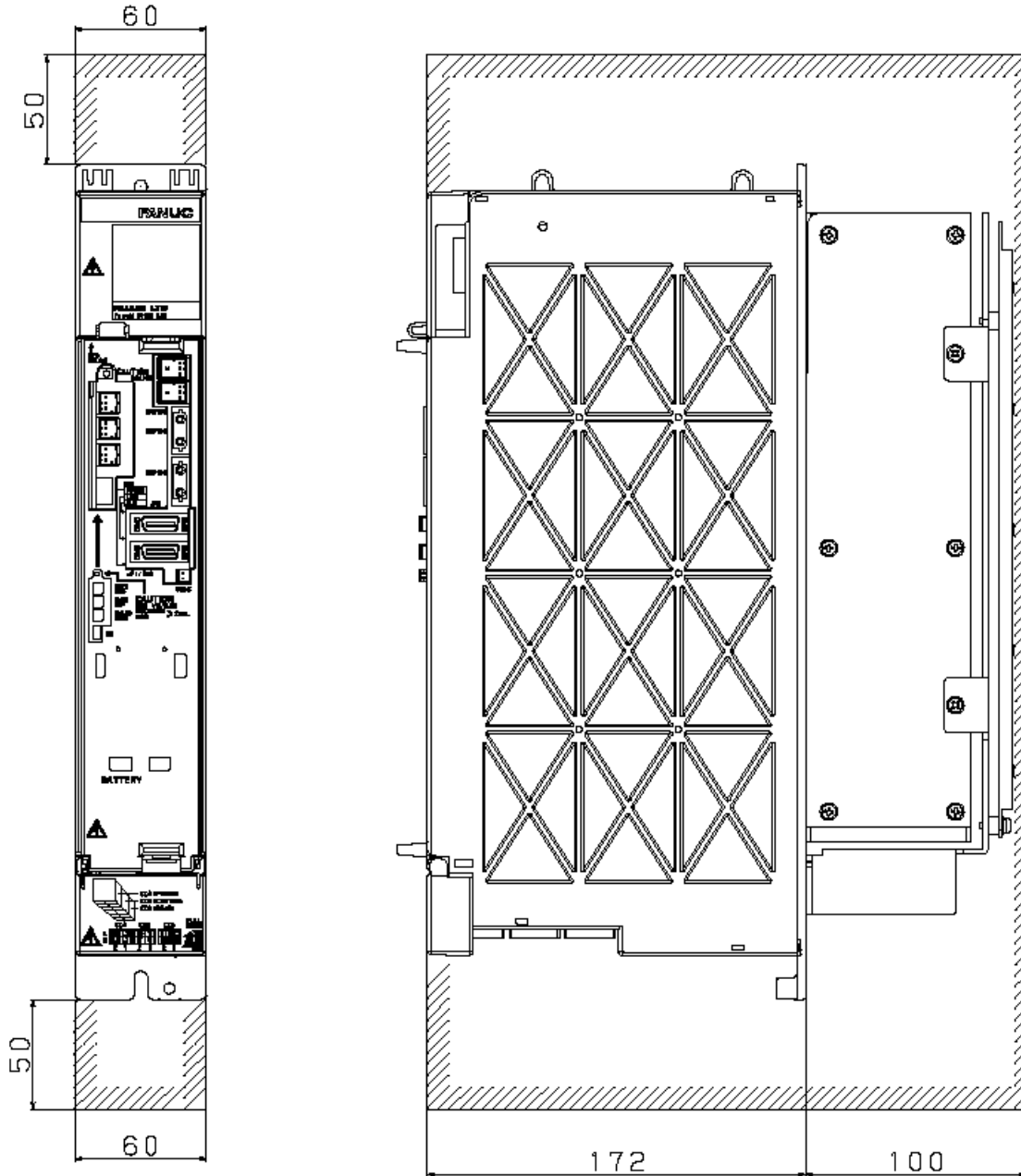

When the cooling fan AC motor (A06B-6134-K002) is used to cool the heat sink

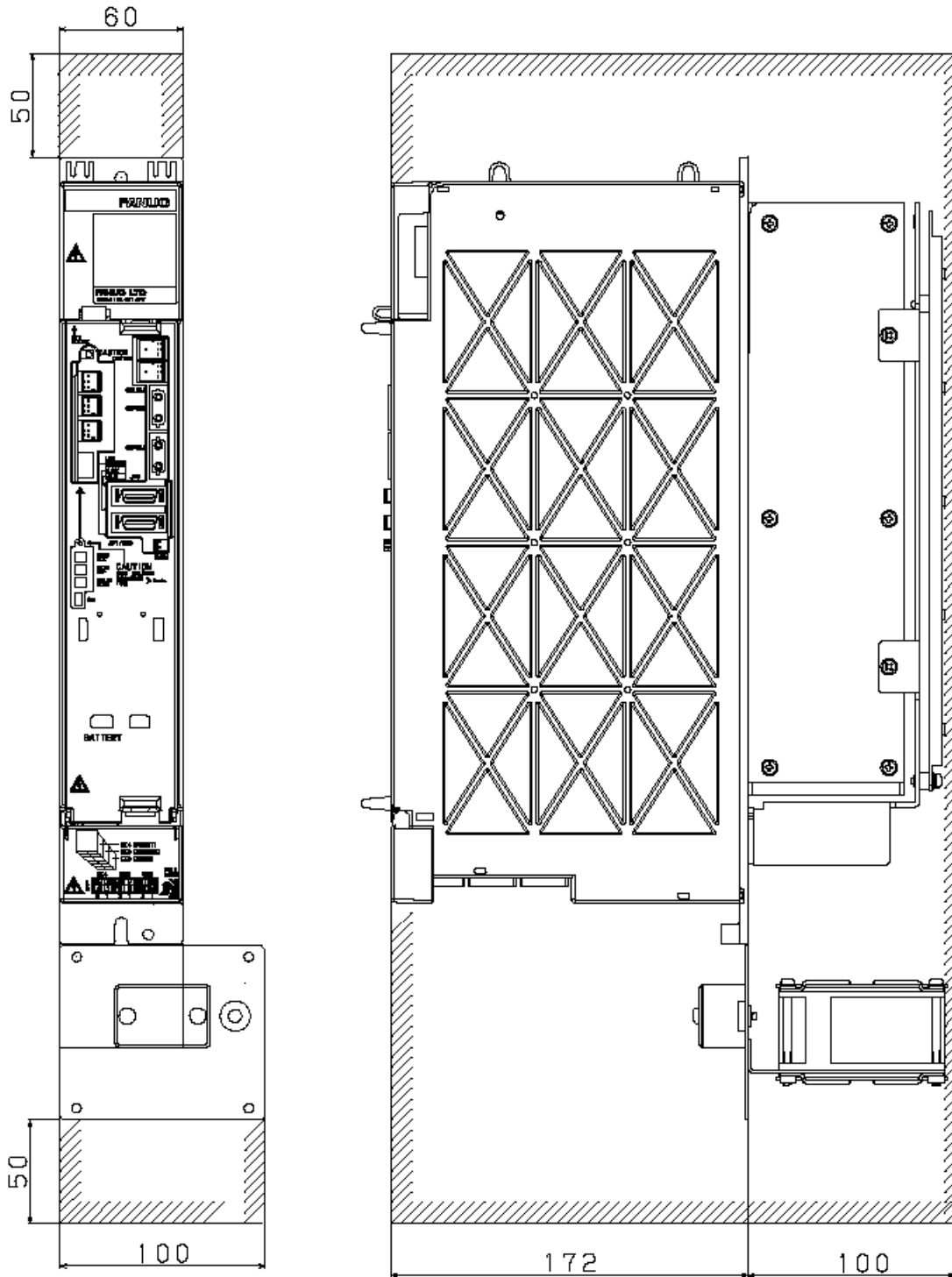

9

TOTAL CONNECTION DIAGRAM

9.1 CONNECTION DIAGRAM

9.1.1 SVM1-4i and SVM1-20i

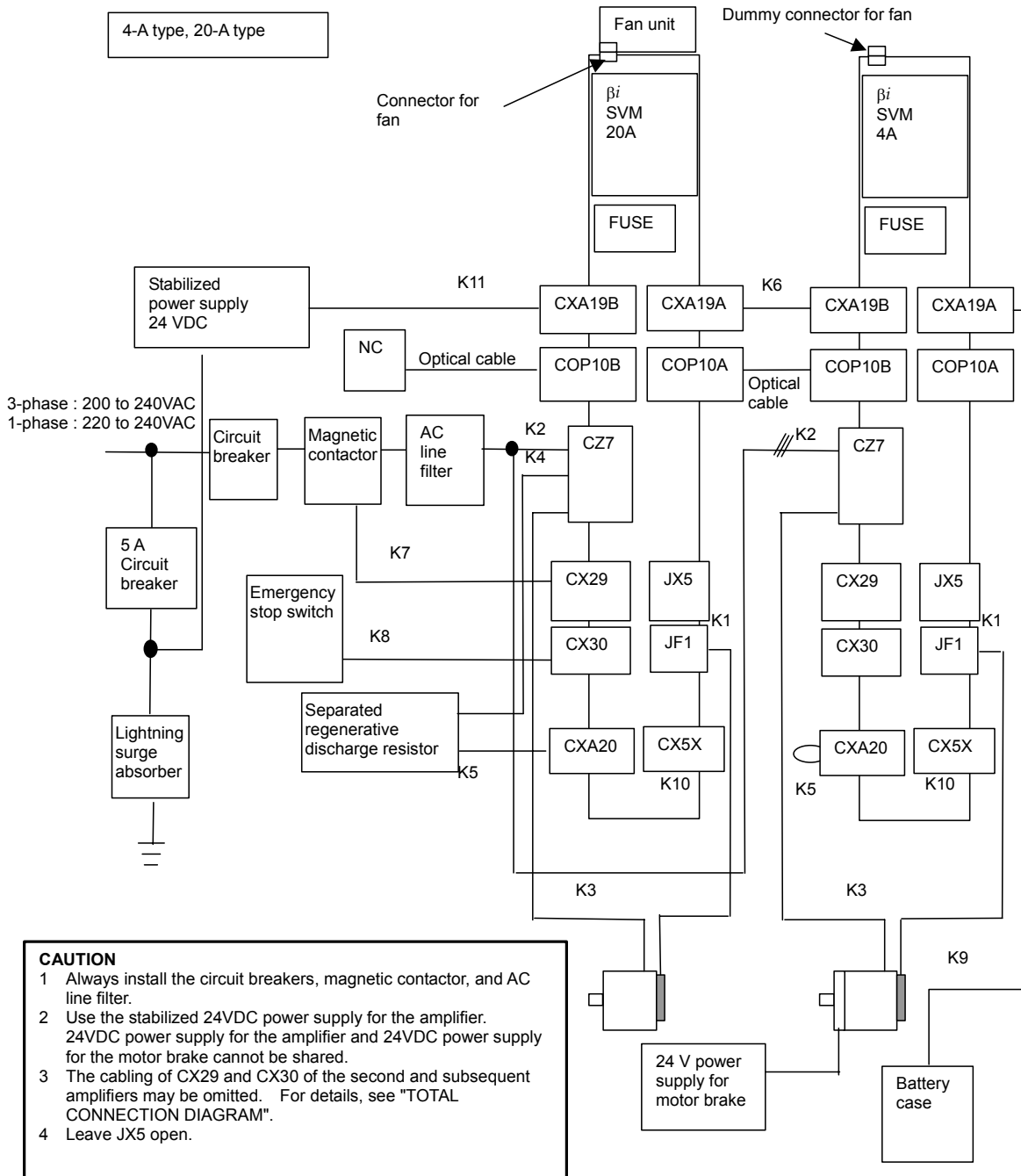

CAUTION

- 1 Always install the circuit breakers, magnetic contactor, and AC line filter.
- 2 Use the stabilized 24VDC power supply for the amplifier. 24VDC power supply for the amplifier and 24VDC power supply for the motor brake cannot be shared.
- 3 The cabling of CX29 and CX30 of the second and subsequent amplifiers may be omitted. For details, see "TOTAL CONNECTION DIAGRAM".
- 4 Leave JX5 open.

NOTE

- 1 Always install the circuit breakers, magnetic contactor, and AC line filter.
- 2 To protect the equipment from lightning surge voltages, install a lightning surge absorber across each pair of power lines and across each power line and the grounding line at the power inlet of the power magnetics cabinet.

**WARNING**

Defects, such as a loose screw and an incorrectly inserted connector, can lead to a motor malfunction, excessive heat generation, and a ground fault.

Exercise adequate care in installing servo amplifiers.

A loose screw (or, if a connector is used, a loose connector contact or an incorrect connector pin-to-cable connection) on high-current carrying power supply wires or motor power wires can lead to fire. Exercise adequate care in wiring.

9.1.2 SVM1-40i and SVM1-80i

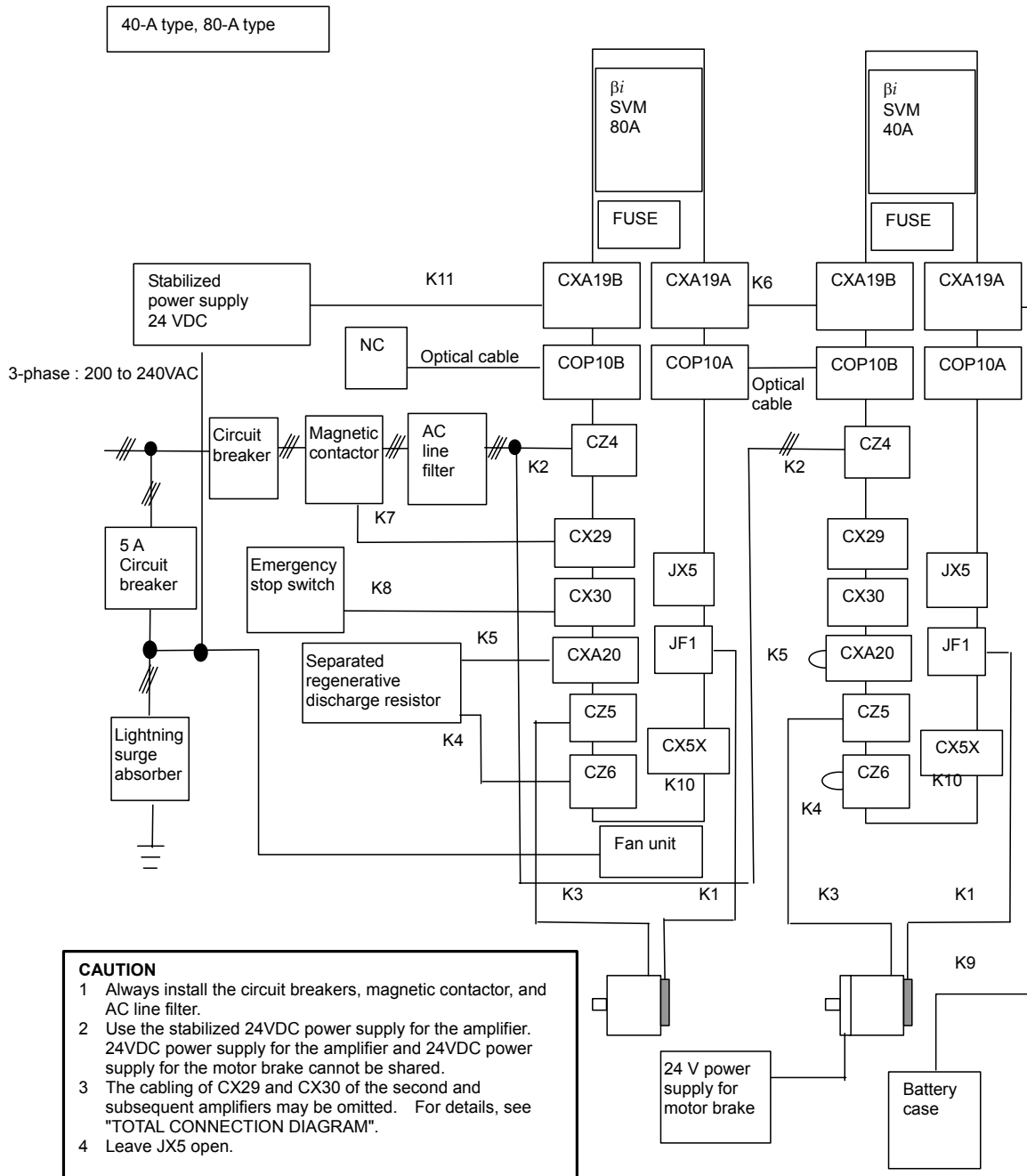

NOTE

- 1 Always install the circuit breakers, magnetic contactor, and AC line filter.
- 2 To protect the equipment from lightning surge voltages, install a lightning surge absorber across each pair of power lines and across each power line and the grounding line at the power inlet of the power magnetics cabinet.

**WARNING**

Defects, such as a loose screw and an incorrectly inserted connector, can lead to a motor malfunction, excessive heat generation, and a ground fault.

Exercise adequate care in installing servo amplifiers.

A loose screw (or, if a connector is used, a loose connector contact or an incorrect connector pin-to-cable connection) on high-current carrying power supply wires or motor power wires can lead to fire. Exercise adequate care in wiring.

9.2 CONNECTOR LOCATION

9.2.1 SVM1-4i and SVM1-20i

No.	Name	Remarks
1		DC link charge LED
2	CZ7-1 CZ7-2	Main power input connector
3	CZ7-3	Discharge register connector
4	CZ7-4 CZ7-5 CZ7-6	Motor power connector
5	CX29	Connector for main power MCC control signal
6	CX30	ESP signal connection connector
7	CXA20	Regenerative resistor connector (for alarms)
8	CXA19B	24VDC power input
9	CXA19A	24VDC power input
10	COP10B	Servo FSSB I/F
11	COP10A	Servo FSSB I/F
12	ALM	Servo alarm status display LED
13	JX5	Connector for testing(*1)
14	LINK	FSSB communication status display LED
15	JF1	Pulsecoder
16	POWER	Control power status display LED
17	CX5X	Absolute Pulsecoder battery
18		Tapped hole for grounding the flange

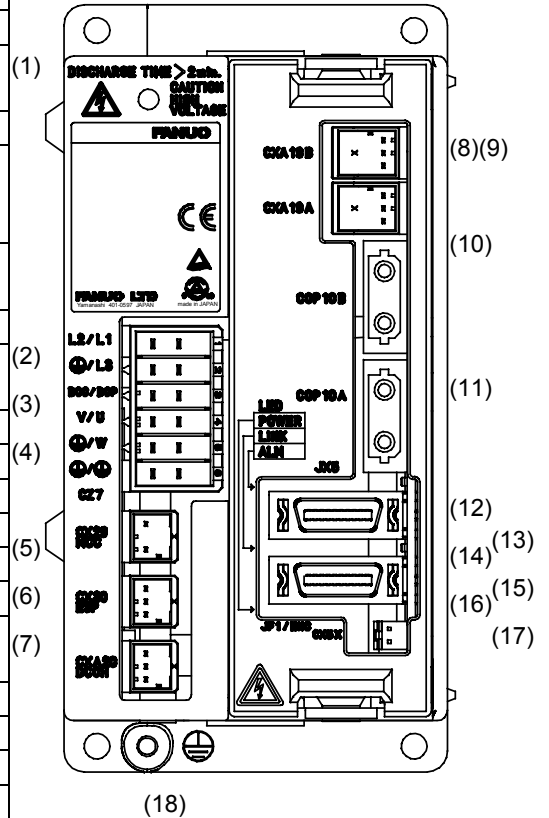

NOTE
*1 Connect nothing to JX5, and leave it open.

9.2.2 SVM1-40i and SVM1-80i

No.	Name	Remarks
1		DC link charge LED
2	CX29	Connector for main power MCC control signal
3	CX30	ESP signal connection connector
4	CXA20	Regenerative resistor connector (for alarms)
5	SW	Setting switch (DC alarm level)
6	CZ4	Main power input connector
7	CZ5	Motor power connector
8	CZ6	Discharge register connector
9	CXA19B	24VDC power input
10	CXA19A	24VDC power input
11	COP10B	Servo FSSB I/F
12	COP10A	Servo FSSB I/F
13	ALM	Servo alarm status display LED
14	JX5	Connector for testing(*1)
15	LINK	FSSB communication status display LED
16	JF1	Pulsecoder
17	POWER	Control power status display LED
18	CX5X	Absolute Pulsecoder battery
19		Tapped hole for grounding the flange

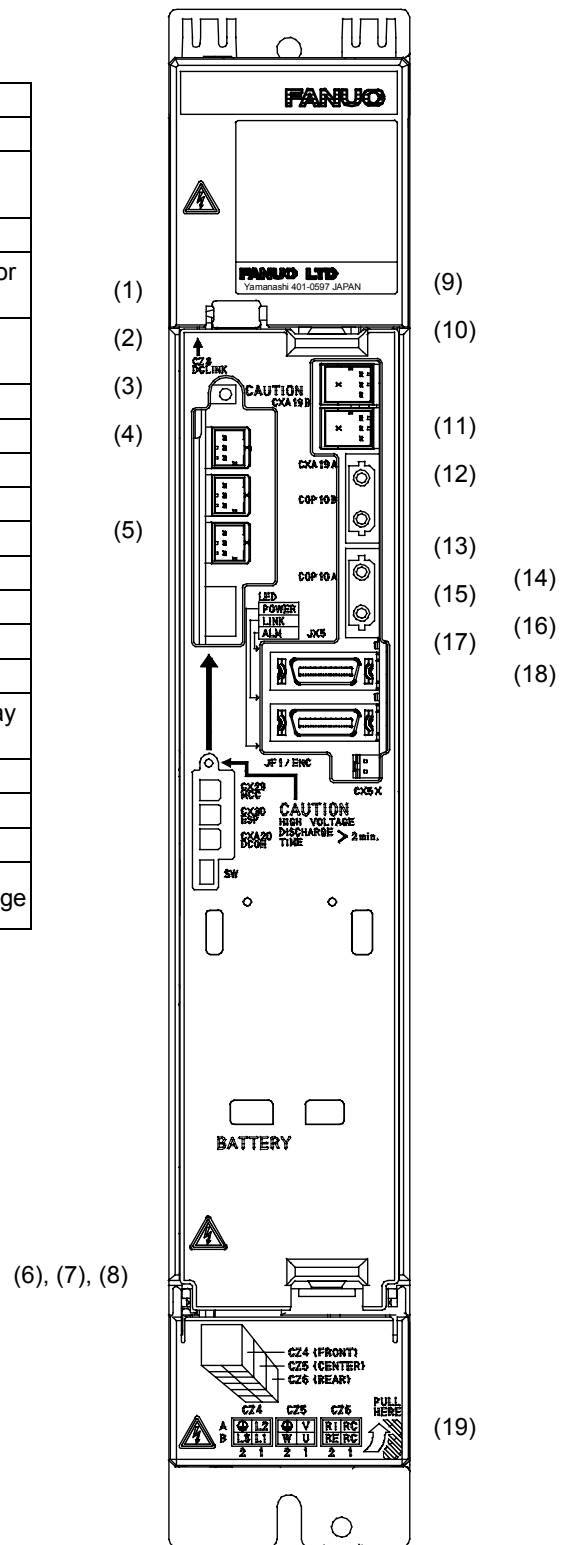

NOTE
 *1 Connect nothing to JX5, and leave it open.

9.2.3 Connection Tools

The ordering specification drawing numbers of connection tools for connectors when the tools are purchased from FANUC are listed below. You may also purchase these tools directly from the manufacturer.

Connectors manufactured by Tyco Electronics AMP

D-2000 series

Type	Ordering specification drawing No.	Manufacturer part No.	Use
Option	A06B-6110-K220#D2M	91595-1	M size Contact crimping tool
Option	A06B-6110-K220#D2R	1276716-1	Contact extractor

D-3000 series

Type	Ordering specification drawing No.	Manufacturer part No.	Use
Option	A06B-6110-K220#D3L	91558-1	L size Contact crimping tool
Option	A06B-6110-K220#D3R	234168-1	Contact extractor

D-5000 series

Type	Ordering specification drawing No.	Manufacturer part No.	Use
Option	A06B-6110-K220#D5SS	91596-1	SS size Contact crimping tool
Option	A06B-6110-K220#D5S	234170-1	S size Contact crimping tool
Option	A06B-6110-K220#D5M	234171-1	M size Contact crimping tool
Option	A06B-6110-K220#D5L	1366044-1	L size Contact crimping tool
Option	A06B-6110-K220#D5R	409158-1	Contact extractor

9.2.4 Details of Cable K1

9.2.4.1 Servo motor αi , αis series, Servo motor βis series ($\beta 0.4/5000is$ to $\beta 22/2000is$)

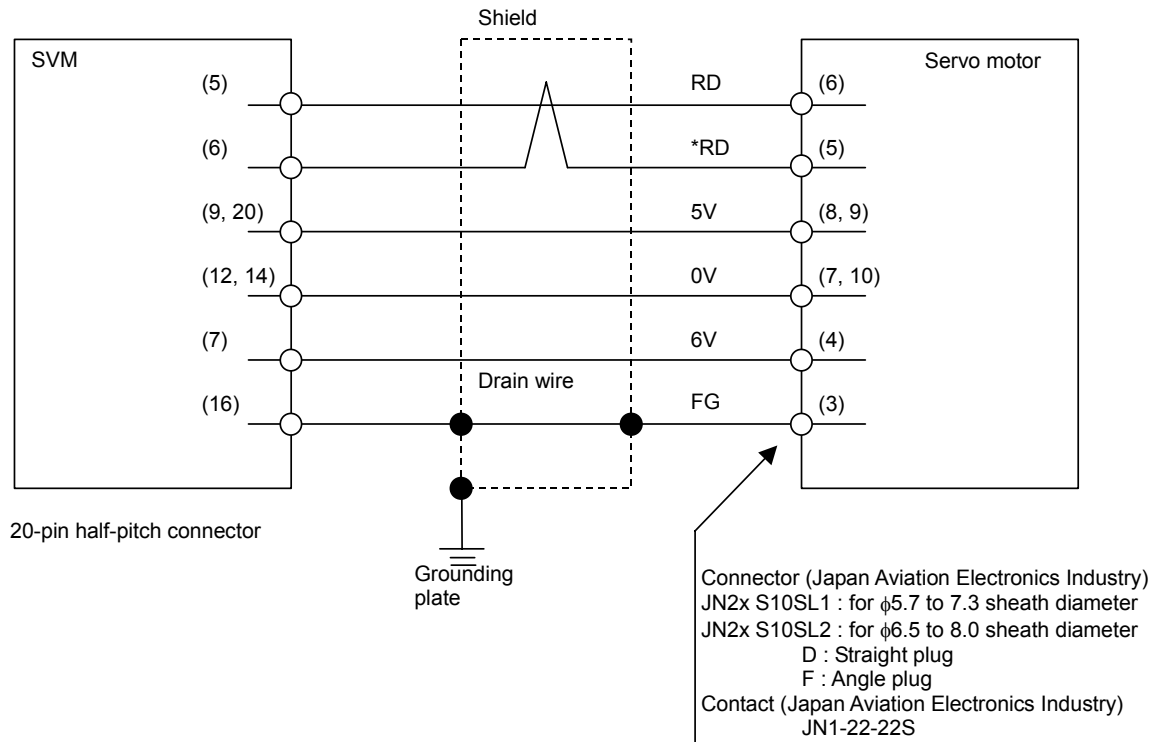

Using cable conductor

Cable length	28 m or less	50 m or less
5V, 0V, 6V	0.3mm ² × 5 Wire construction 12/0.18 or 60/0.08 Insulation outer diameter $\phi 1.5$ or less	0.5mm ² × 5 Wire construction 20/0.18 or 104/0.08 Insulation outer diameter $\phi 1.5$ or less
RD, *RD	0.18mm ² or more Twisted-pair wire	0.18mm ² or more Twisted-pair wire
Drain wire	0.15mm ² or more	0.15mm ² or more

NOTE

The ground plate to which the shield is connected must be placed as close as possible to the servo amplifier so that distance between the ground plate and the servo amplifier becomes shortest.

* This applies also to the αMi and αCi series servo motors.

NOTE

- 1 In case that the cable is prepared by MTB, total resistance of 5V and 0V must be less than 2Ω .
- 2 Pulsecoder side connector can accept maximum 0.5mm^2 (wire construction 20/0.18 or 104/0.08, insulation outer diameter $\phi 1.5$ or less) wire and sheath diameter is $\phi 5.7$ to $\phi 8.0$. In case of using thicker wire or cable, take measures described below.

[Case 1] Cable conductor exceeds 0.5mm^2 .

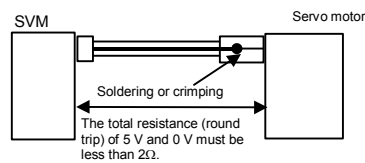

[Case 2] Sheath diameter of exceeds $\phi 8$.

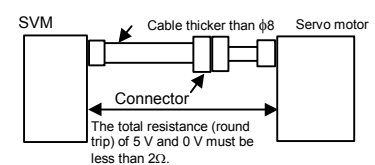

- 3 In case of incremental Pulsecoder, 6V is not necessary to be connected.

- Crimp tool specification
A06B-6114-K201/JN1S : For 0.3mm^2
A06B-6114-K201/JN1L : For 0.18mm^2 or 0.5mm^2
- Connector kit specification
A06B-6114-K204/S : Straight plug (including a contact)
A06B-6114-K204/E : Elbow plug (including a contact)
- Recommended cable
A66L-0001-0460 : Flexible cable 28 m or less long
A66L-0001-0462 : Flexible cable 50 m or less long
A66L-0001-0481 : Fixed cable 28m or less long
A66L-0001-0491 : Fixed cable 50m or less long

9.2.4.2 Servo motor β is series (β 0.2/5000is, β 0.3/5000is)

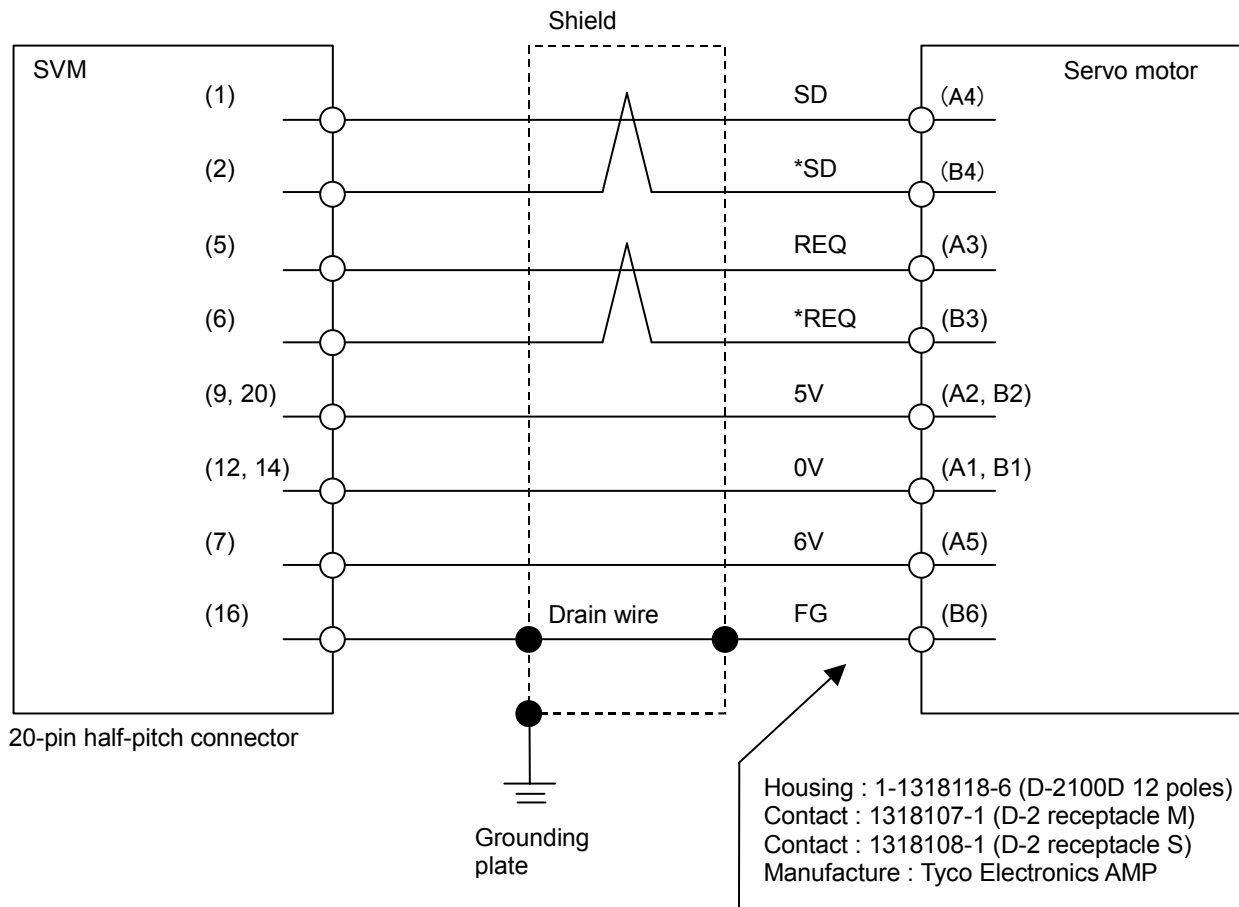

Using cable conductor

Cable length	20 m or less
5V, 0V, 6V	0.5 mm ² (AWG21) × 5 Wire construction 20/0.18 Insulation outer diameter φ0.88 to φ1.5
SD, *SD, REQ, *REQ	0.18mm ² (AWG25) or more Twisted-pair wire Wire construction 7/0.18 Insulation outer diameter φ0.88 to φ1.5
Drain wire	0.15mm ² or more
Recommended wire	0.5mm ² × 5 + 0.18mm ² × two-pair (For a fixed cable) Hitachi Cable, Ltd. : UL20276-SB (0) 5X21AWG+2PX25AWG (For a flexible cable) Hitachi Cable, Ltd. : UL20276-SB (FLEX) 5X20AWG+2PX25AWG

NOTE

- 1 The ground plate to which the shield is connected must be placed as close as possible to the servo amplifier so that distance between the ground plate and the servo amplifier becomes shortest.
- 2 In case that the cable is prepared by the user, the total resistance (round trip) of 5 V and 0 V must be less than 0.8Ω .
- 3 The maximum applicable wire diameter of the cable connector on the motor side is 0.5 mm^2 (when crimping tool 1463475-1 is used) or 0.85 mm^2 (when crimping tool 1276654-1 is used). In case of using thicker wire or cable, take measures described below.

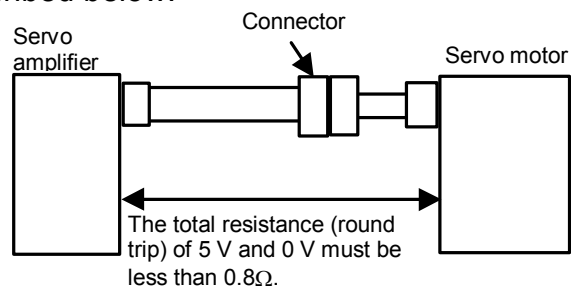

- 4 In case of incremental Pulsecoder, 6 V is not necessary to be connected.

9.2.5 Details of Cable K2

The following items related to servo amplifier input cables are explained below in the stated order.

- (1) Details of connectors
- (2) Selecting input cables (general)
- (3) Details of input cables

9.2.5.1 Details of connectors

(a) SVM1-4i, SVM1-20i

Three-phase input

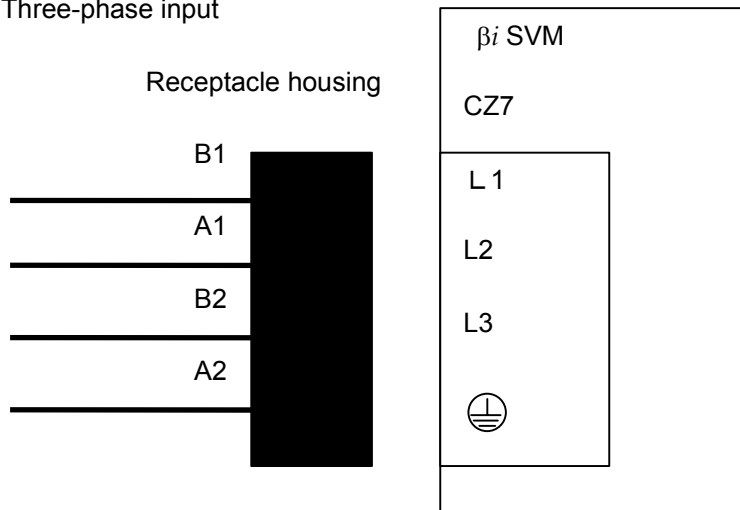

Single-phase input

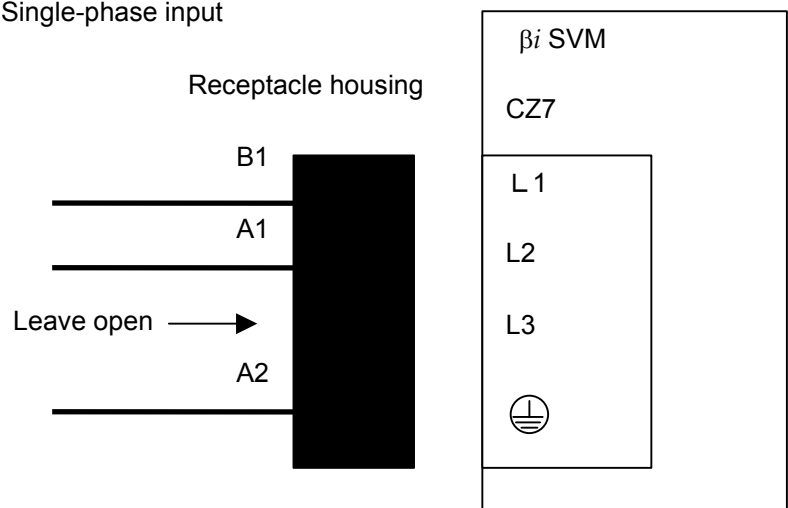

[Receptacle housing]

Use the following receptacle housing.

Manufacturer-defined model	Specification of the key	Manufacture
175363-3	Incorrect-insertion prevent key	Tyco Electronics AMP

[Receptacle contact]

Two receptacle contact types are available, so as to support different conductor diameters. Be sure to select the receptacle contact that matches the servo axis you use.

Rectangle contact model number		Conductor size (mm ²)	Conductor size AWG	Insulation outer diameter (mm)	Manual tool model number	Manufacture
L size	1-175218-2	0.5- 1.25	20/18/16	1.8-2.8	91558-1	Tyco Electronics AMP

[Connector and tool ordering information]

Connectors (including housings and contacts) and tools can be purchased directly from Tyco Electronics AMP. They can be ordered as options also from FANUC as listed below.

Ordering number	Description
A06B-6130-K200	Housing : Incorrect-insertion prevent key 175363-3 (1pcs.) Incorrect-insertion prevent key 1318095-2 (1pcs.) Contact : L size 1-175218-2 (10pcs.) Applicable wire diameter: 0.5-1.25mm ² , AWG20/18/16 Applicable tool: 91558-1 (not included in this kit)

(b) SVM1-40i, SVM1-80i

Receptacle housing

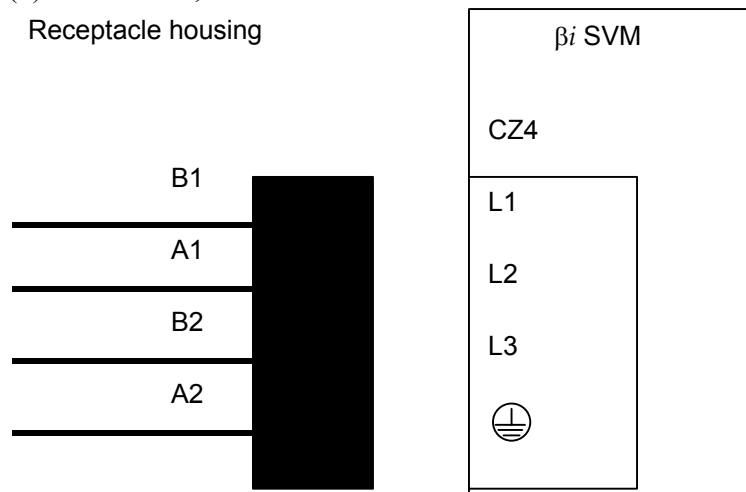

[Receptacle housing]

Use the following receptacle housing.

Manufacturer-defined model	Specification of the key	Manufacture
1-917807-2	XX	Tyco Electronics AMP

[Receptacle contact]

Rectangle contact model number		Conductor size (mm ²)	Conductor size AWG	Insulation outer diameter (mm)	Manual tool model number	Manufacture
S size	316040-6	1.25 – 2.20	16/14	3.0-3.8	234170-1	Tyco Electronics AMP
M size	316041-6	3.50 – 5.50	12/10	4.0-5.2	234171-1	Tyco Electronics AMP

[Connector and tool ordering information]

Connectors (including housings and contacts) and tools can be purchased directly from Tyco Electronics AMP. They can be ordered as options also from FANUC as listed below.

Ordering number	Description
A06B-6110-K200#XXS	Housing : XX key 1-917807-2 (1pcs.) Contact : S size 316040-6 (4pcs.) Applicable wire diameter : 1.25-2.20mm ² , AWG16/14 Applicable tool: 234170-1 (not included in this kit)
A06B-6110-K200#XXM	Housing : XX key 1-917807-2 (1pcs.) Contact : M size 316041-6 (4pcs.) Applicable wire diameter : 3.50-5.50mm ² , AWG12/10 Applicable tool : 234171-1 (not included in this kit)

[Crimping tool]

Ordering number	Description
A06B-6110-K220#D5S	Applicable tool : 234170-1 Contact : S size 316040-6 Applicable wire diameter : 1.25-2.2mm ² , AWG16/14
A06B-6110-K220#D5M	Tool : 234171-1 Contact : M size 316041-6 Applicable wire diameter: 3.50-5.50mm ² , AWG12/10
A06B-6110-K220#D5R	Extractor : 409158-1

9.2.5.2 Selecting cables (general)

Select the cable specification by considering the following conditions for use:

- (1) Motor current rating or current needed in use on a real machine
- (2) Cable type (heat resistance temperature, etc.)
- (3) Environment in which the cable is installed (operating ambient temperature, etc.)
- (4) Certification for CE marking (compliance with various safety standards and EMC standard)

Examples of selecting a heavy-duty power cable are shown below. Fully check the cable specifications based on the actual use conditions and use an example below.

The cable diameters are determined based on JCS No. 168 D (1980), "Allowable Currents for Power Cables (1)."

Selection example of power line (reference)

[Selection example 1]

- Heavy-duty power cable specification :
Maximum allowable conductor temperature 60°C
- Environment temperature : 30°C

Cable diameter [mm ²]	Allowable current value [Arms]	Receptacle contact specification
0.75	Less than 11	L size 1-175218-2
1.25	Less than 15	L size 1-175218-2 S size 316040-6
2	Less than 19	S size 316040-6
3.5	Less than 27	M size 316041-6
5.5	Less than 35	M size 316041-6

[Selection example 2]

- Heavy-duty power cable specification :
Maximum allowable conductor temperature 80°C
- Environment temperature : 55°C

Cable diameter [mm ²]	Allowable current value [Arms]	Receptacle contact specification
0.75	Less than 9.2	L size 1-175218-2
1.25	Less than 12.7	L size 1-175218-2 S size 316040-6
2	Less than 16.3	S size 316040-6
3.5	Less than 23.4	M size 316041-6
5.5	Less than 31.2	M size 316041-6

9.2.5.3 Details of input cables

Select cables by taking the following conditions for use into account.

[Example combinations of input cables for servo motors running with continuous-rating output (reference only)]

Servo motor	Continuous current rating for three-phase input [Arms] (reference only)	Continuous current rating for single-phase input [Arms] (reference only)	[Example 1.] Cable wire diameter [mm ²]	[Example 2.] Cable wire diameter [mm ²]
$\beta 0.2/5000is$	0.2	0.5	0.75 (0.75)	0.75 (0.75)
$\beta 0.3/5000is$	0.5	1.1	0.75 (0.75)	0.75 (0.75)
$\beta 0.4/5000is$	0.7	1.4	0.75 (0.75)	0.75 (0.75)
$\beta 0.5/5000is$	1.1	2.2	0.75 (0.75)	0.75 (0.75)
$\beta 1/5000is$	2.1	4.3	0.75 (0.75)	0.75 (0.75)
$\beta 2/4000is$	2.6	5.4	0.75 (0.75)	0.75 (0.75)
$\beta 4/4000is$	3.9	8.1	0.75 (0.75)	0.75 (0.75)
$\beta 8/3000is$	6.3	9.7	0.75 (0.75)	0.75 (1.25)
$\beta 12/3000is$	9.4	-	0.75	1.25
$\beta 22/2000is$	13.1	-	1.25	2
$\alpha 1/5000i$	2.6	5.4	0.75 (0.75)	0.75 (0.75)
$\alpha 2/5000i$	3.9	8.1	0.75 (0.75)	0.75 (0.75)
$\alpha 4/4000i$	7.3	-	0.75	0.75
$\alpha 8/3000i$	8.4	-	0.75	0.75
$\alpha 12/3000i$	15.7	-	2	2
$\alpha 22/3000i$	21.0	-	3.5	3.5
$\alpha 2/5000is$	3.9	8.1	0.75 (0.75)	0.75 (0.75)
$\alpha 4/5000is$	5.2	9.7	0.75 (0.75)	0.75 (1.25)
$\alpha 8/4000is$	13.1	-	1.25	2
$\alpha 12/4000is$	14.2	-	1.25	2

9.2.6 Details of Cable K3

The following items related to servo motor/amplifier power cables are explained below in the stated order.

- (1) Details of connectors
- (2) Selecting power cables (general)
- (3) Power cable for servo motor

9.2.6.1 Details of connectors

The D-3000 and -5000 connector series (manufactured by Tyco Electronics AMP.) are used for power cable connection in the βi series. The specifications of a receptacle housing and contact vary depending on the model for which they are used as stated below.

(a) SVM1-4*i*, SVM1-20*i*

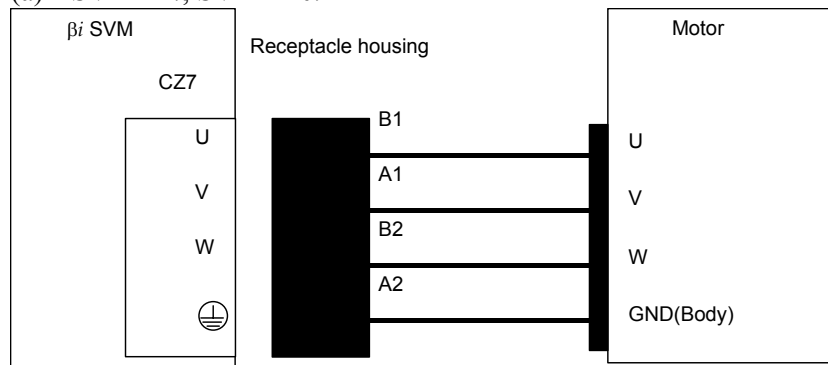

[Receptacle housing]

Use the following receptacle housing.

Manufacturer-defined model	Manufacture
1318095-2	Tyco Electronics AMP

[Receptacle contact]

Two receptacle contact types are available, so as to support different conductor diameters. Be sure to select the receptacle contact that matches the servo axis you use.

Rectangle contact model number		Conductor size (mm ²)	Conductor size AWG	Insulation outer diameter (mm)	Manual tool model number	Manufacture
L size	1-175218-2	0.5-1.25	20/18/16	1.8-2.8	91558-1	Tyco Electronics AMP

[Connector and tool ordering information]

Connectors (including housings and contacts) and tools can be purchased directly from Tyco Electronics AMP. They can be ordered as options also from FANUC as listed below.

See Subsection 5.2.4 “Details of Cable K2.”

(b) SVM1-40i, SVM1-80i



[Receptacle housing]

Use the following receptacle housing.

Manufacturer-defined model	Specification of the key	Manufacture
2-917807-2	YY	Tyco Electronics AMP

[Receptacle contact]

Rectangle contact model number		Conductor size (mm ²)	Conductor size AWG	Insulation outer diameter (mm)	Manual tool model number	Manufacture
S size	316040-6	1.25–2.2	16/14	3.0-3.8	234170-1	Tyco Electronics AMP
M size	316041-6	3.5–5.5	12/10	4.0-5.2	234171-1	Tyco Electronics AMP

[Connector and tool ordering information]

Connectors (including housings and contacts) and tools can be purchased directly from Tyco Electronics AMP. They can be ordered as options also from FANUC as listed below.

Ordering number	Description
A06B-6110-K202#YYS	Housing : YY key 2-917807-2 (1pcs.)
	Contact : S size 316040-6 (4pcs.)
	Applicable wire diameter : 1.25-2.20mm ² , AWG16/14
	Applicable tool : 234170-1 (not included in this kit)
A06B-6110-K202#YYM	Housing : YY key 2-917807-2 (1pcs.)
	Contact : M size 316041-6 (4pcs.)
	Applicable wire diameter : 3.50-5.50mm ² , AWG12/10
	Applicable tool : 234171-1 (not included in this kit)

9.2.6.2 Details of cables (general)

See Subsection 5.2.4 “Details of Cable K2.”

9.2.6.3 Power cable for servo motor

A servo motor power cable assembly consists of:

- (a) Power cable
- (b) Motor-side connector

- (a) Power cable

Examples of combining a servo motor and power cable are described below according to Subsection 5.2.4.2, “Selecting cables (general).”

[Example combination of servo motor and power cable (reference only)]

Servo motor	Continuous current rating [Amps] (reference only)	[Example 1.] Cable wire diameter [mm ²]	[Example 2.] Cable wire diameter [mm ²]
β 0.2/5000is	0.84	0.75	0.75
β 0.3/5000is	0.84	0.75	0.75
β 0.4/5000is	3.5	0.75	0.75
β 0.5/5000is	3.0	0.75	0.75
β 1/5000is	2.7	0.75	0.75
β 2/4000is	3.2	0.75	0.75
β 4/4000is	4.7	0.75	0.75
β 8/3000is	6.0	0.75	0.75
β 12/3000is	10.2	0.75	1.25
β 22/2000is	11.3	1.25	1.25
α 1/5000i	2.7	0.75	0.75
α 2/5000i	3.5	0.75	0.75
α 4/4000i	7.7	0.75	0.75
α 8/3000i	8.4	0.75	0.75
α 12/3000i	18.1	2	3.5
α 22/3000i	18.4	2	3.5
α 2/5000is	3.3	0.75	0.75
α 4/5000is	4.6	0.75	0.75
α 8/4000is	11.1	1.25	1.25
α 12/4000is	13.4	1.25	2

- (b) Motor-side connector

The specifications of a motor-side connector vary depending on the motor model for which it is used.

Refer to “FANUC AC SERVO MOTOR β is series Descriptions” (B-65302EN) for detailed descriptions about motor-side connectors for the β is series servo motors.

Refer to “FANUC AC SERVO MOTOR α is/ α i series Descriptions” (B-65262EN) for detailed descriptions about motor-side connectors for the α is/ α i series servo motors.

9.2.7 Details of Cables K4 and K5

9.2.7.1 SVM1-4i and SVM1-20i

When a regenerative discharge resistor is used

The following regenerative discharge resistor models are available.

A06B-6130-H401	The following housing and contact are connected to the resistor.
A06B-6130-H402	The following housing and contact are connected to the resistor.

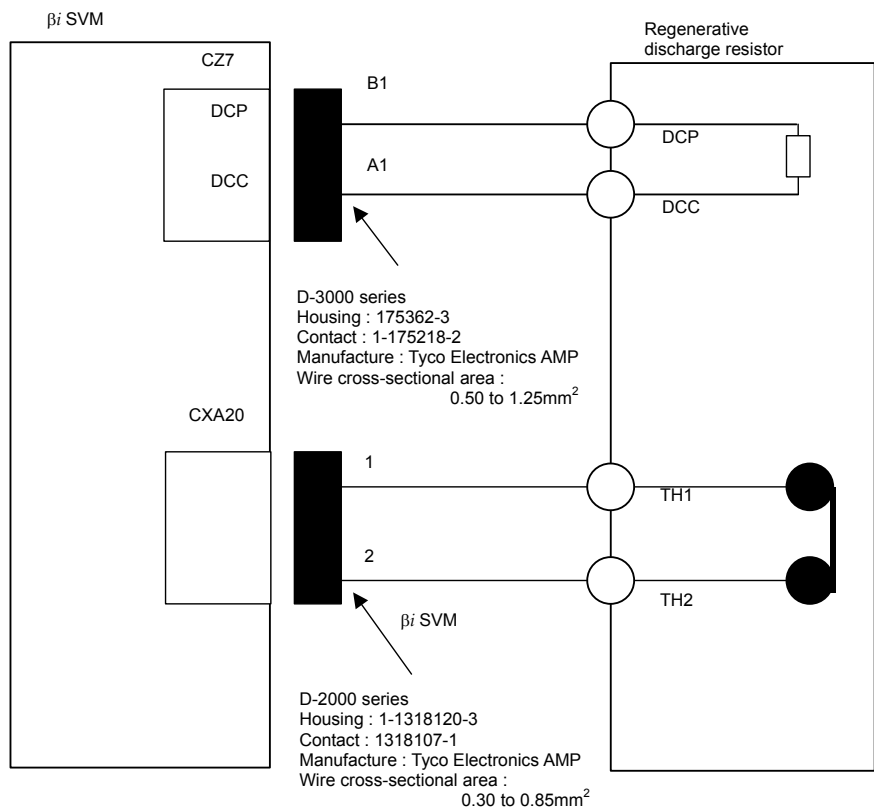

For connection tools, see Subsection 9.2.3.

When no regenerative discharge resistor is used

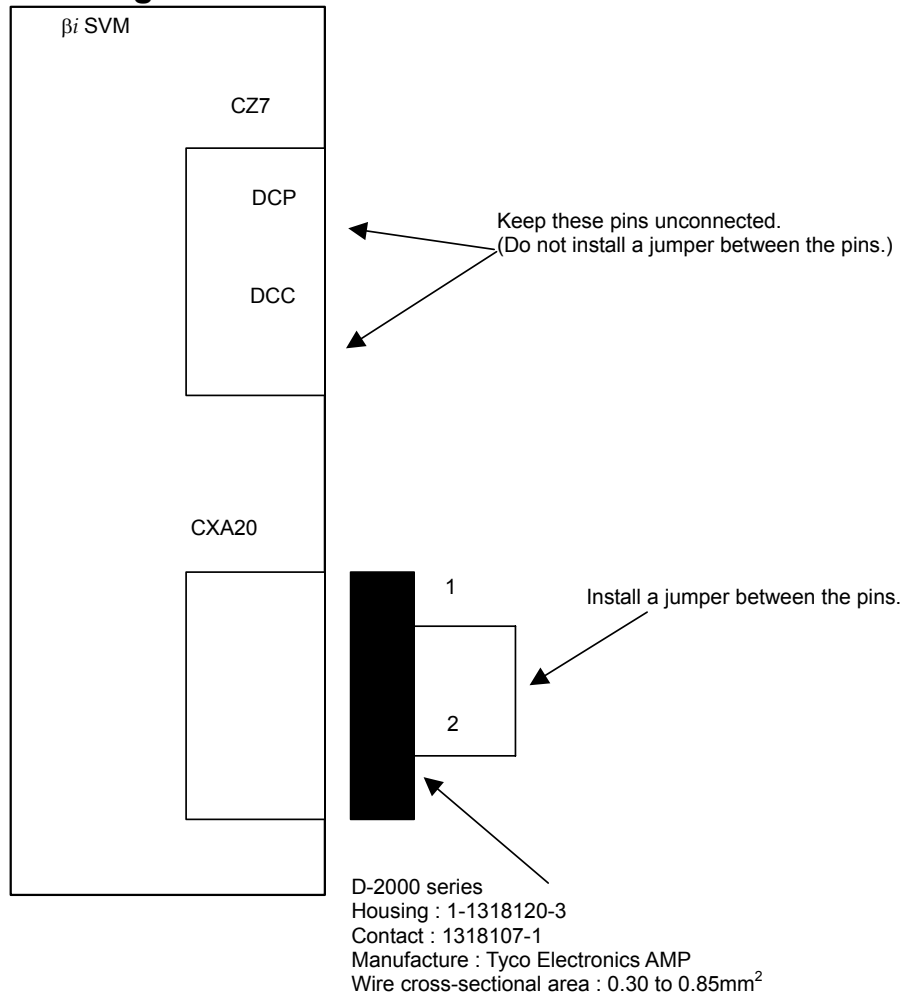

For connection tools, see Subsection 9.2.3.

⚠ CAUTION
 Do not connect the DCP and DCC pins to each other.
 It is recommended that the housing 1313182-2 be inserted to prevent incorrect insertion.

9.2.7.2 SVM1-40i and SVM1-80i

When a separated regenerative discharge resistor is used

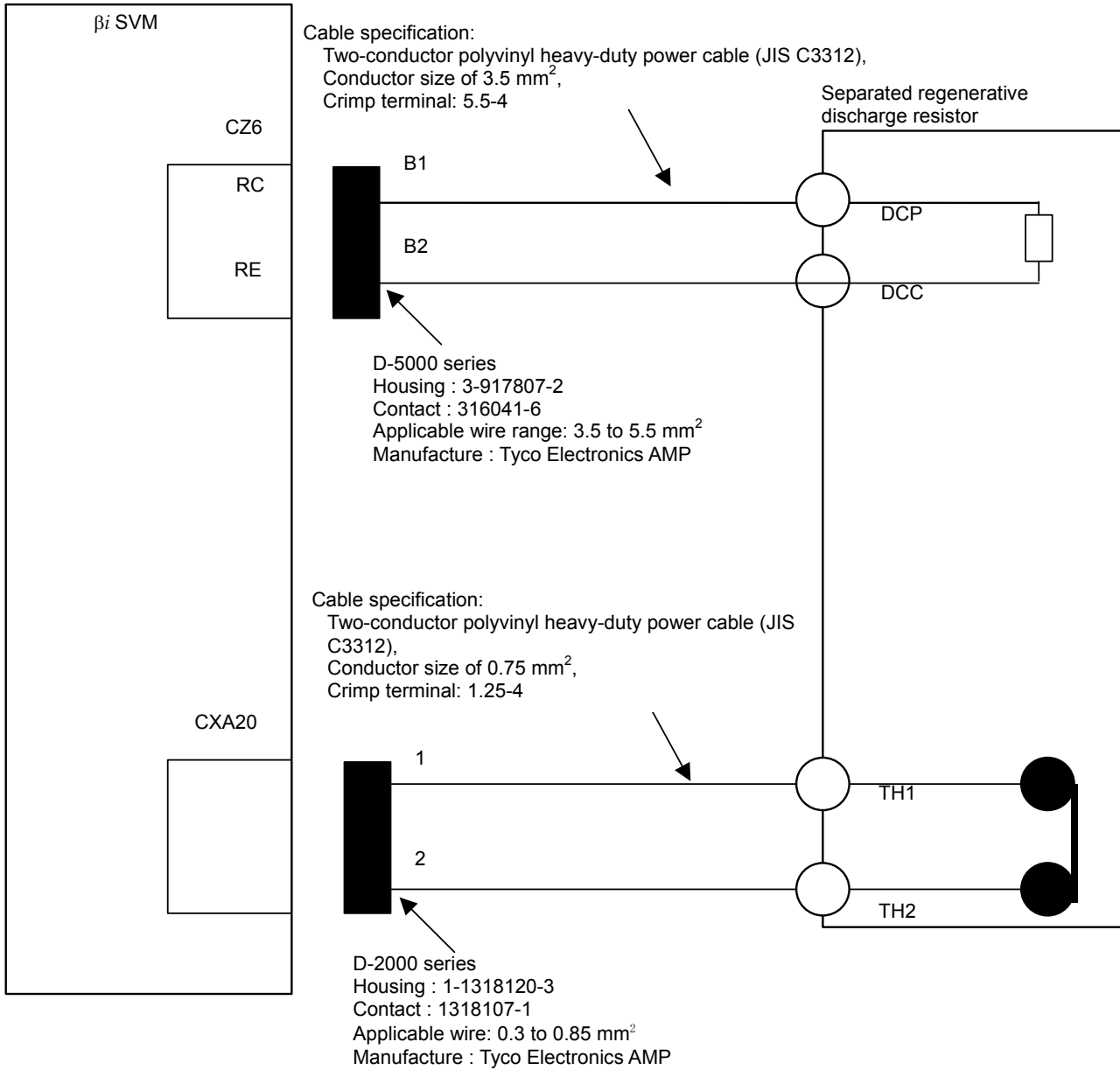

For connection tools, see Subsection 9.2.3.

When a built-in regenerative discharge resistor is used

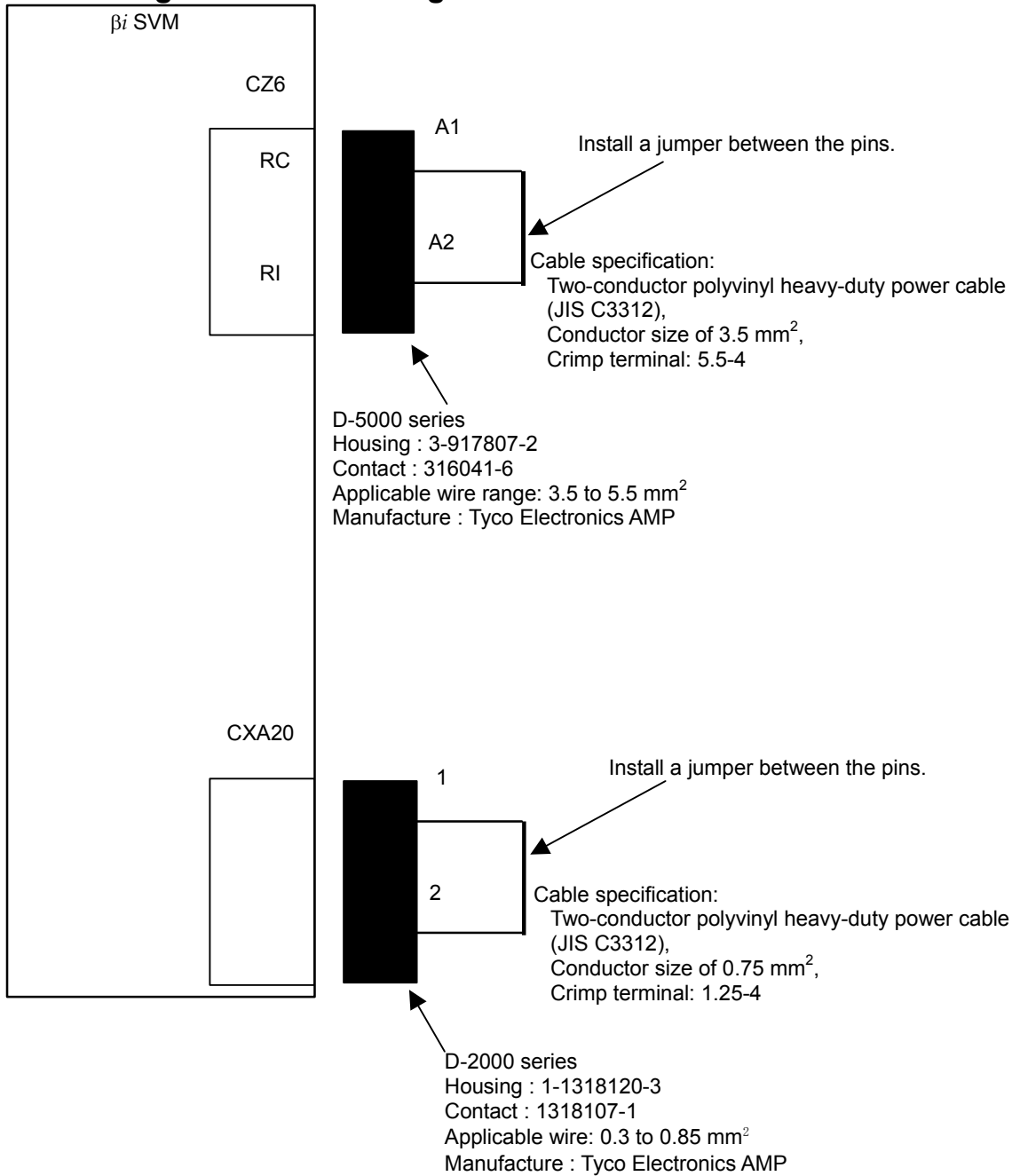

For connection tools, see Subsection 9.2.3.

9.2.8 Details of Cable K6

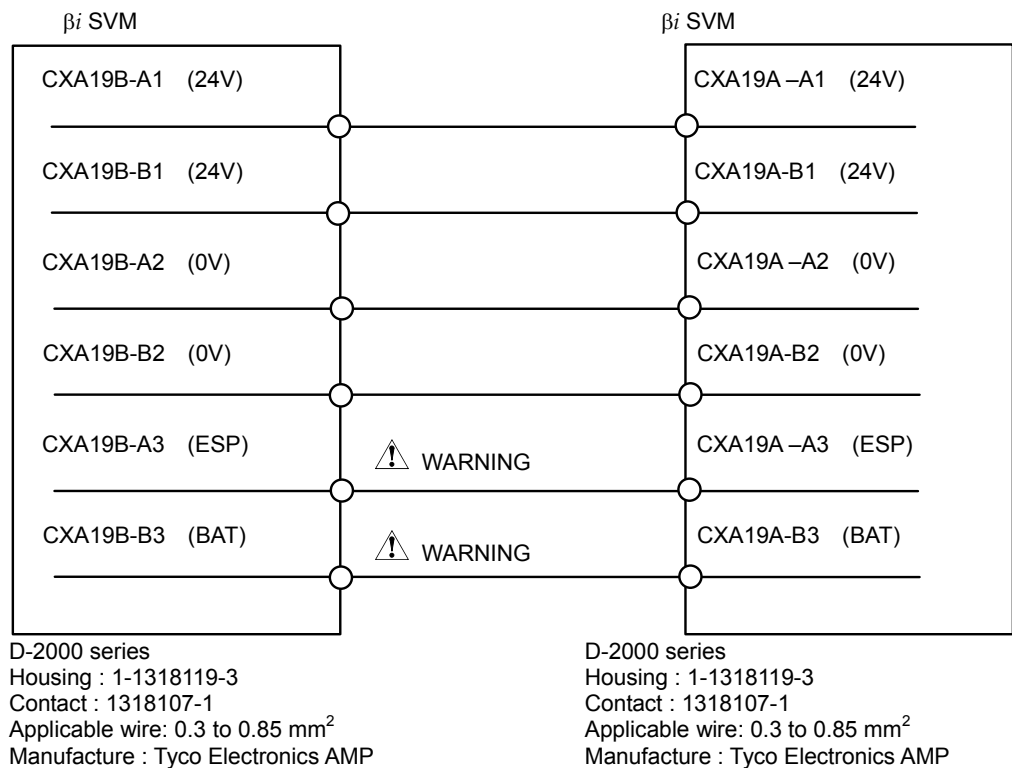

NOTE

The (B3)BATL is the interface used to connect the batteries for the absolute Pulsecoder. For details, see the description of battery connection.

⚠ WARNING

- 1 When connecting two or more servo amplifiers, be careful about the way the ESP (A3) is connected, because even when the emergency stop button is pressed, it may fail to stop the motor promptly. For details, see "Details of Cable K8."
- 2 When using the built-in battery (A06B-6093-K001), never connect the BAT(B3) of the connector CXA19A/CXA19B. Otherwise, a short-circuit will occur between the battery output voltages for different SVMs, possibly resulting in the batteries becoming very hot, which is dangerous.
- 3 Do not connect more than one battery to the same BAT(B3) line. Otherwise, a short-circuit will occur between the output voltages of different batteries, possibly resulting in the batteries becoming very hot, which is dangerous.

9.2.9 Details of Cable K7

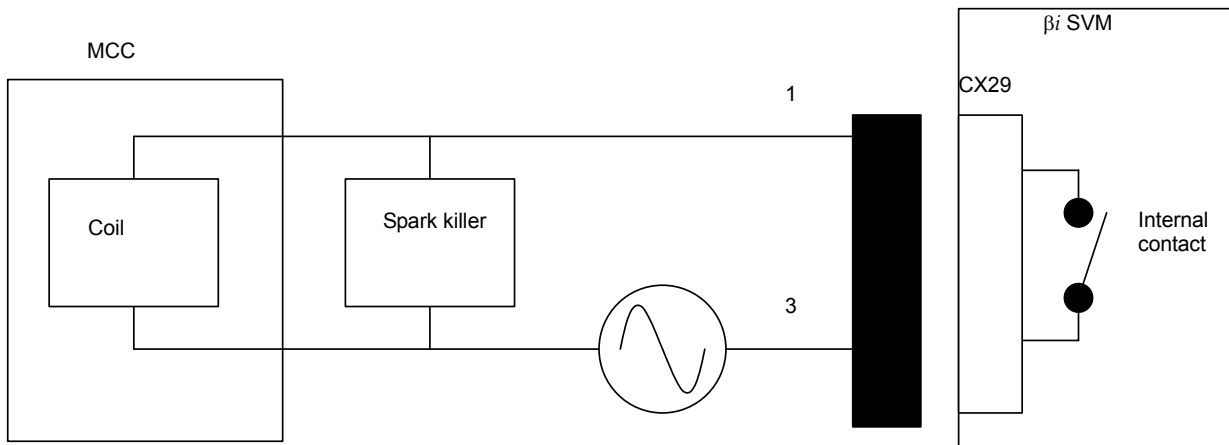

External power supply
(Use an appropriate power supply for the coil voltage the customer uses.)

D-2000 series
Housing : 3-1318130-3
Contact : 1318107-1
Applicable wire: 0.3 to 0.85 mm²
Manufacture : Tyco Electronics AMP

For connection tools, see Subsection 9.2.3.

Internal contact capacity

	Resistance load (COS φ=1)	Inductive load (COS φ=0.4, L/R=15msec)
Rated load	250VAC, 3A / 24VDC, 5A	250VAC, 2A / 24VDC, 1A
Maximum contact capacity	5A	5A

NOTE

- 1 To protect the internal contact, be sure to insert a spark killer (CR) that matches the magnetic contactor used.
- 2 When more than one servo amplifier is connected, the cabling of the second and subsequent amplifiers may be omitted.

9.2.10 Details of Cable K8

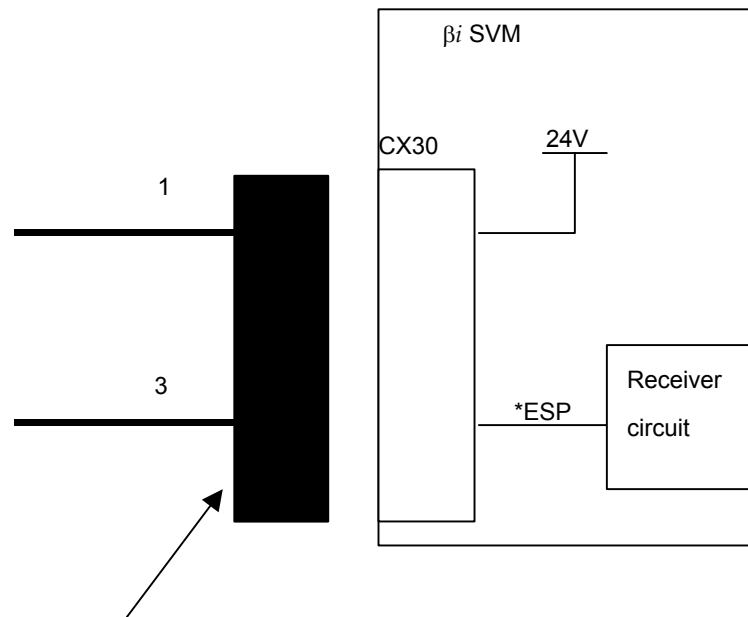

D-2000 series

Housing : 2-1318120-3

Contact : 1318107-1

Applicable wire: 0.3 to 0.85mm²

Manufacture : Tyco Electronics AMP

For connection tools, see Subsection 9.2.3.

- (1) When the contact is ON (closed), the servo motor is operational. When the contact is OFF (open), the external magnetic contactor (MCC) is in the off state, and the servo motor does not operate.
- (2) When the contact is set to OFF (open) while the motor is turning, the servo motor is stopped by the dynamic brake.
- (3) The contact input signal is defined as follows:
 - <1> As the external contact capacity, a voltage of at least 30 VDC and a current of at least 100 mA are required.
 - <2> When contactless input is used, the significant levels (the voltage across the input pin) are as follows:
 - Low level "logic 0": 2 V or less
 - High level "logic 1": 20 V or more

Emergency stop signal (*ESP) block diagram

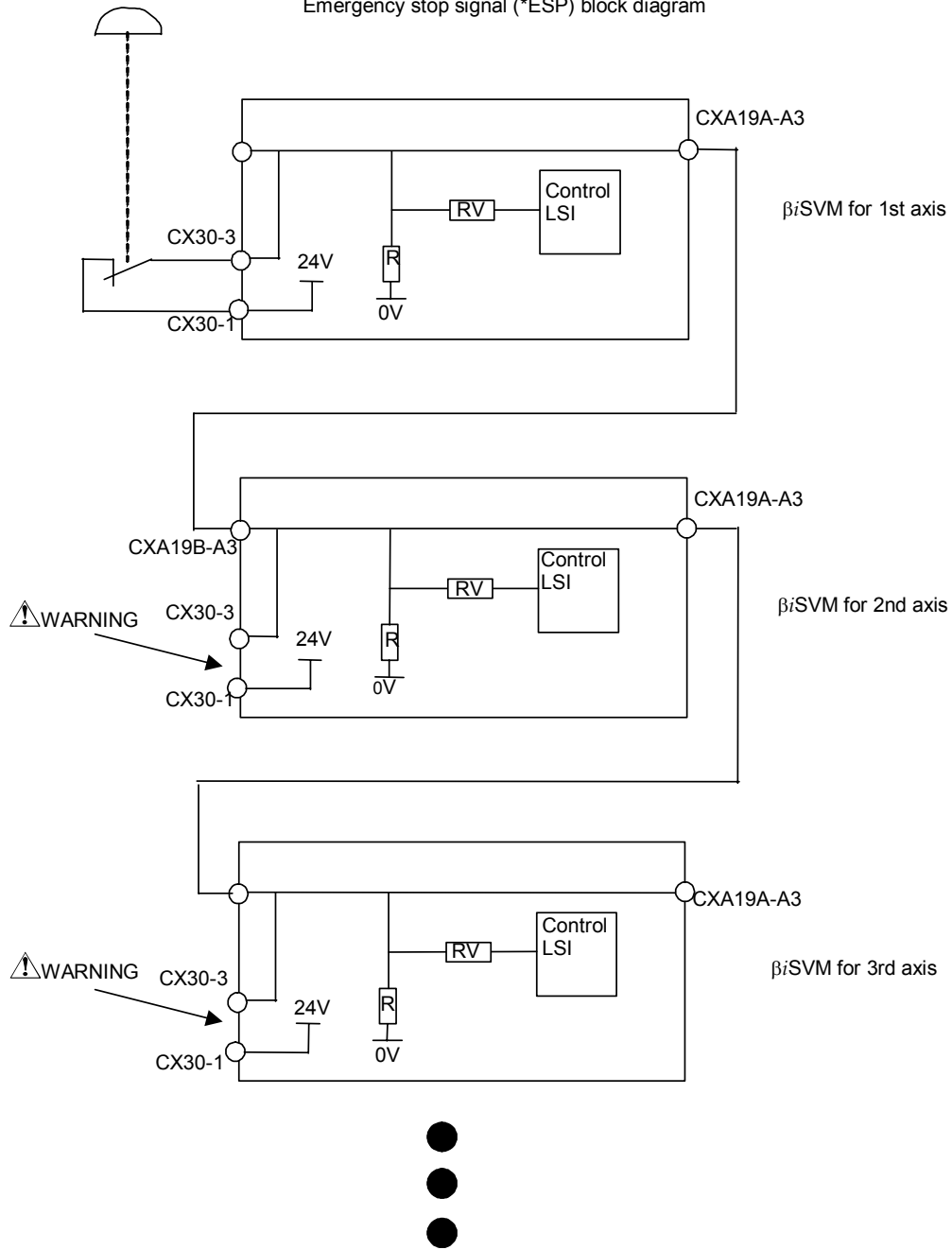

⚠ WARNING
 When connecting more than one amplifier, leave connector CX30 of every amplifier for the second and subsequent axes open.
 (Never connect these connectors with a wire, a switch, or the like.)
 Even when the emergency stop button is pressed, the motors may not stop immediately.

9.2.11 Details of Cable K9

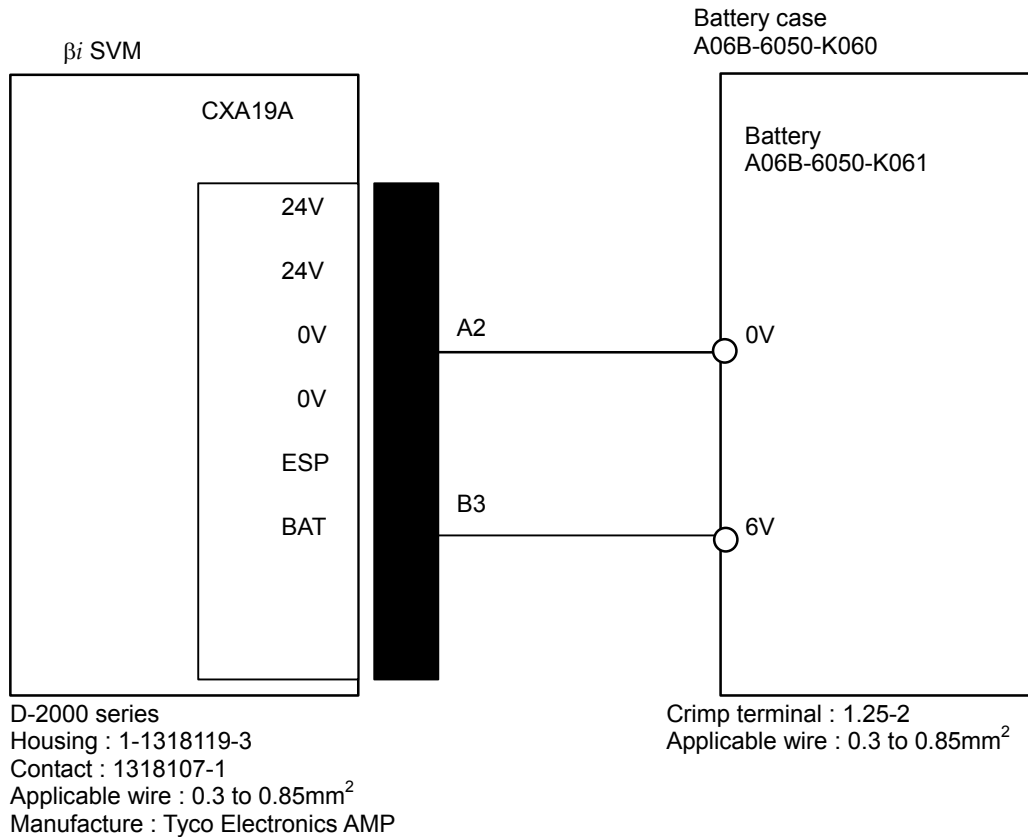

For connection tools, see Subsection 9.2.3.

NOTE

- 1 Because the battery requires periodic maintenance, the above connection method is recommended, where easily available commercial batteries (four size D alkaline batteries) can be used.
- 2 Servo motors for six axes can be connected to one battery unit.
- 3 If servo motors for six axes are connected to the battery unit, the service life of the battery unit is about two years for the βi series servo motors or about one year for the β series servo motors. The battery should be replaced periodically.



WARNING

Do not connect more than one battery to the same BATL(B3) line. Otherwise, a short-circuit will occur between the output voltages of different batteries, possibly resulting in the batteries becoming very hot, which is dangerous.

9.2.12 Details of Cable K10

- (1) Incorporating built-in batteries in each SVM
(For SVM1-4i or SVM1-20i)

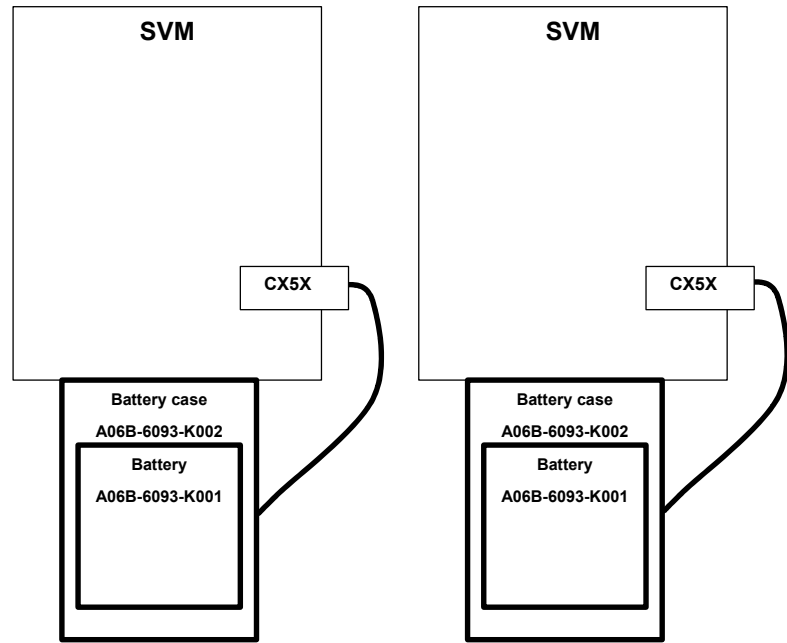

- Using the built-in battery (A06B-6093-K001) requires the battery case (A06B-6093-K002).

WARNING

- 1 When using the built-in battery (A06B-6093-K001), never connect the BAT(B3) of the connector CXA19A/CXA19B. Otherwise, a short-circuit will occur between the output voltages of different SVM batteries, possibly resulting in the batteries becoming very hot, which is dangerous.
- 2 Do not connect more than one battery to the same BAT(B3) line. Otherwise, a short-circuit will occur between the output voltages of different batteries, possibly resulting in the batteries becoming very hot, which is dangerous.

- (2) Incorporating built-in batteries in each SVM
(For SVM1-40i or SVM1-80i)

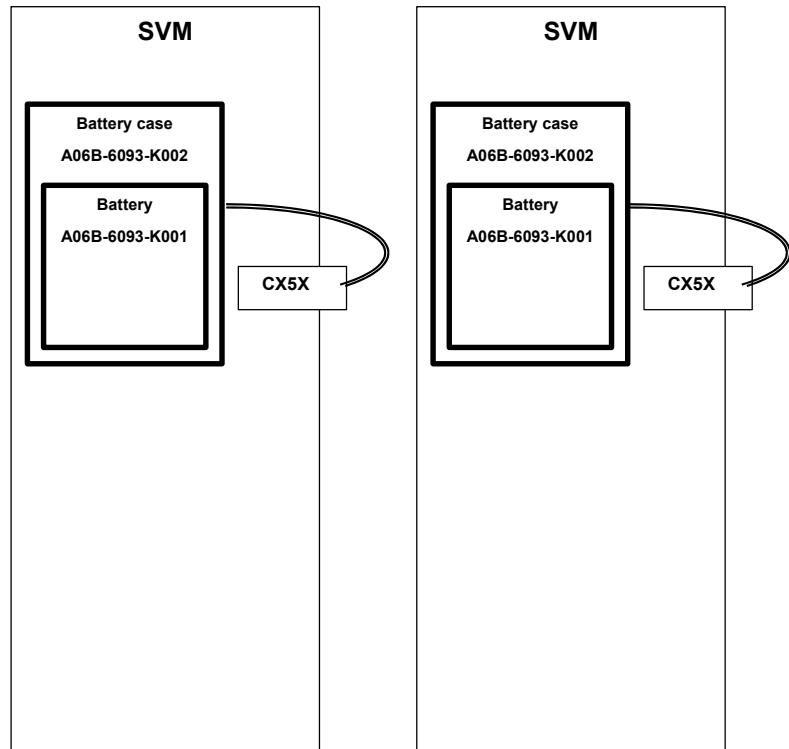

- Using the built-in battery (A06B-6093-K001) requires the battery case (A06B-6093-K002).

⚠ WARNING

- 1 When using the built-in battery (A06B-6093-K001), never connect the BAT(B3) of the connector CXA19A/CXA19B. Otherwise, a short-circuit will occur between the output voltages of different SVM batteries, possibly resulting in the batteries becoming very hot, which is dangerous.
- 2 Do not connect more than one battery to the same BAT(B3) line. Otherwise, a short-circuit will occur between the output voltages of different batteries, possibly resulting in the batteries becoming very hot, which is dangerous.

9.2.13 Details of Cable K11

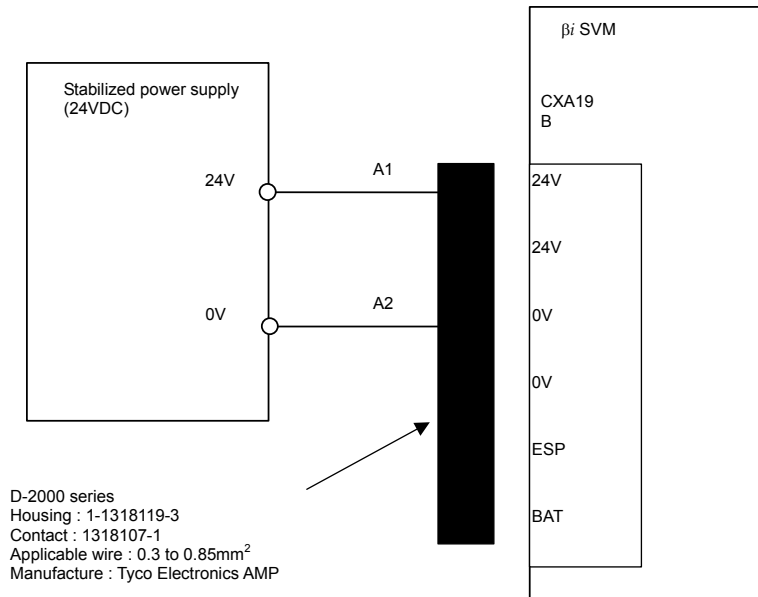

Up to four units can be connected (when AWG#18 cable is used).

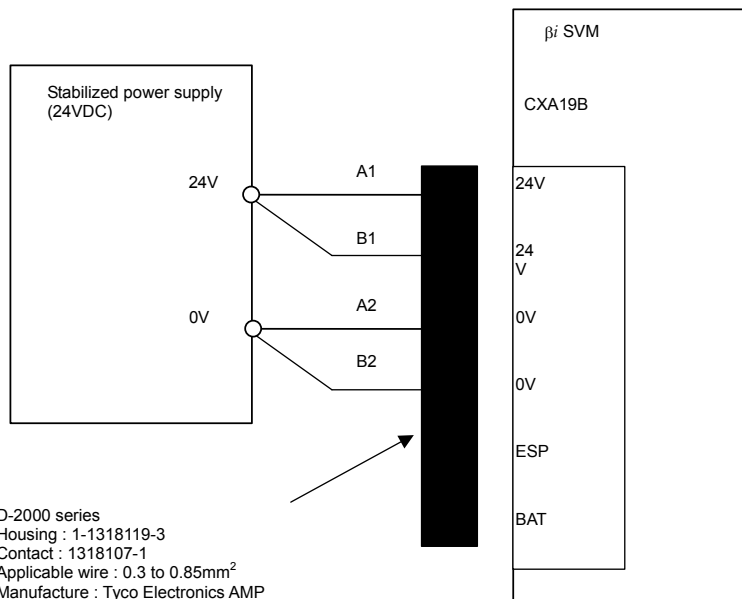

Up to eight units can be connected (when AWG#18 cable is used)

Maximum permissible current of the connector

	When only one pin is connected
Maximum permissible current	4 A/pin (when AWG#18 cable is used)

For connection tools, see Subsection 9.2.3.

9.3 HANDLING OF EXTERNAL MAGNETIC CONTACTORS

This section explains how to handle external magnetic contactors when FSSB interface SVMs and I/O Link interface SVMs are used together.

- 1 Multiple FSSB interface SVMs can share an external magnetic contactor. Determine the capacity of the magnetic contactor from the sum of the power supply ratings of the SVMs.
- 2 It is recommended that one external magnetic contactor be prepared for each I/O link interface SVM.

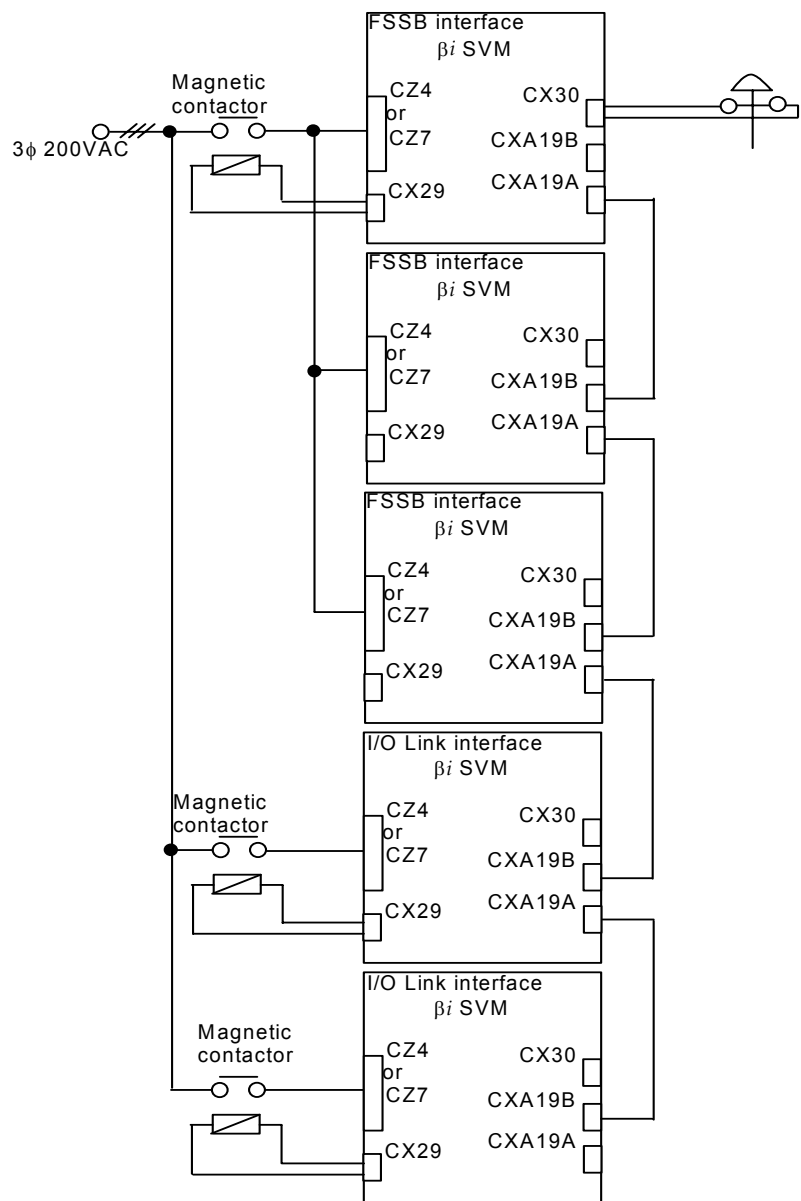

10 HEAT DISSIPATION

The amount of heat dissipation depends on the SVM model and the current that flows through the servo motor. For the current that flows through a servo motor, reference the continuous rated current of each servo motor. (For the continuous rated current of each servo motor, refer to the servo motor descriptions.) As the current that flows through a servo motor, the root-mean-square value of the current that flows through an actual servo motor on a machine can be used. The amount of heat dissipation indicated below assumes the use of HRV2.

(1) Total amount of heat dissipation

The total amount of heat dissipation is calculated according to the following expression:

$$\text{Total amount of heat dissipation} = a + K a_1 \times b_1$$

a : Amount of heat dissipation determined by the SVM model [W]

Ka1 : Coefficient determined by the SVM [W/Arms]

b1 : Current flowing through the servo motor [Arms]

Total amount of heat dissipation

Name	Specification	a [W]	K [W/Arms]
SVM1-4i	H001	20	Ka1: 8.1
SVM1-20i	H002	20	Ka1: 7.7
SVM1-40i	H003	20	Ka1: 7.1
SVM1-80i	H004	20	Ka1: 6.7

(2) Residual amount of heat in the cabinet

By placing the heat sink section outside the cabinet, the residual amount of heat in the cabinet can be calculated according to the expression below.

$$\text{Residual amount of heat in the cabinet} = a + K b_1 \times b_1$$

a : Amount of heat dissipation determined by the SVM model [W]

Kb1 : Coefficient determined by the SVM [W/Arms]

b1 : Current flowing through the servo motor [Arms]

Residual amount of heat in the cabinet

Name	Specification	a [W]	K [W/Arms]
SVM1-4i	H001	20	Kb1: 8.1
SVM1-20i	H102	20	Kb1: 7.7
SVM1-40i	H003	20	Kb1: 1.4
SVM1-80i	H004	20	Kb1: 0.7

II. SVPM

1

OVERVIEW

The β i series SVPM has the following features:

- (1) Because a power supply is incorporated, a system with two or three servo axes and one spindle can be built easily.
- (2) Multi-axis AC servo amplifier with excellent cost performance
- (3) This unit is designed in compliance with the following safety standards:
 - EN50178
 - UL508C
 - CSA C22.2
 - EN61000-6-2
 - EN55011
- (4) This multi-axis AC servo amplifier is suitable for the servo motor β i series, which is suitable for feed axes of machining tools, and the spindle motor β i series, which is suitable for a spindle.

2

CONFIGURATION

Configuration of β i series servo amplifier SVPM

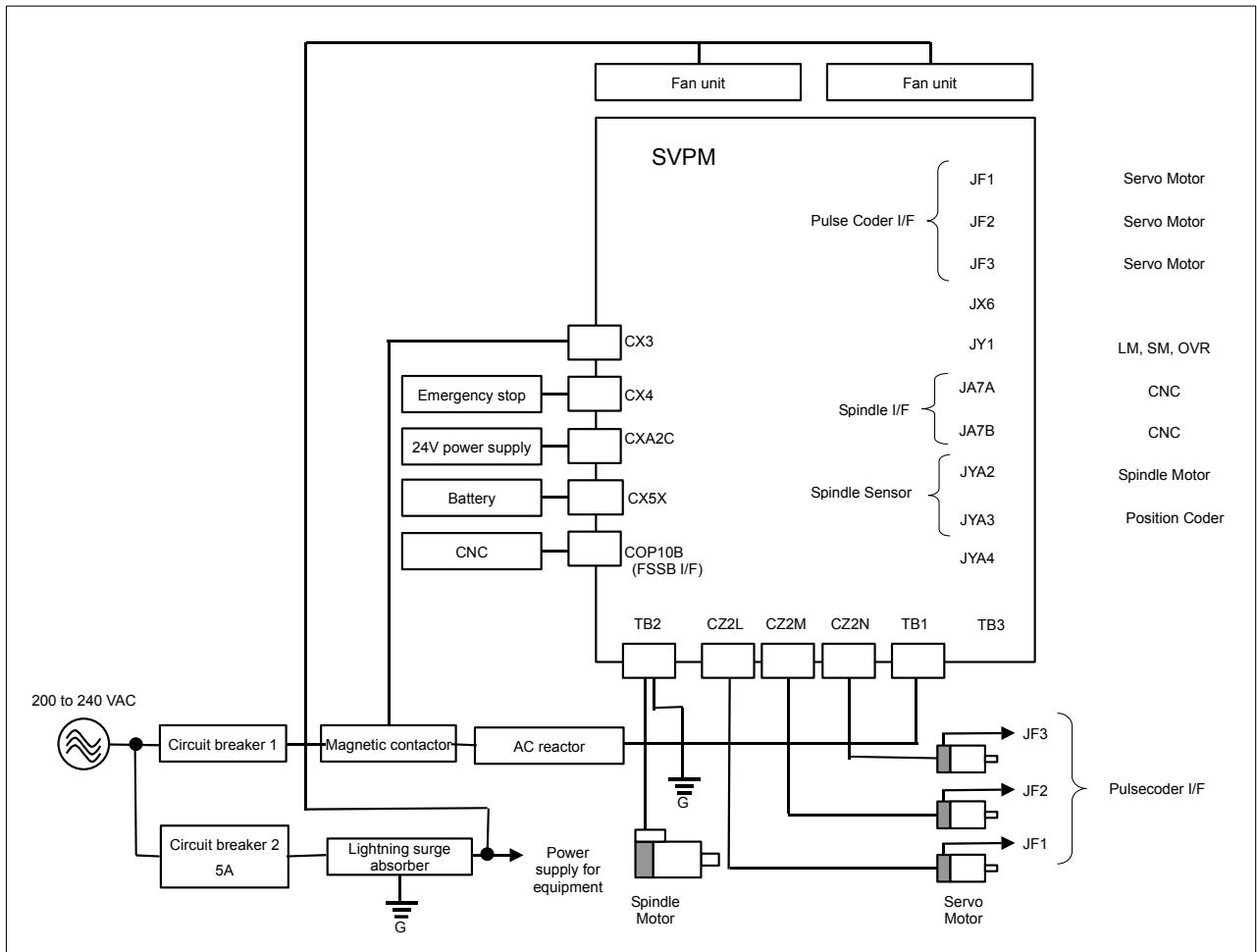

3

SPECIFICATIONS

3.1 SPECIFICATIONS

Two-axis type (SVPM2)

Item	SVPM2-5.5i (TypeA)	SVPM2-5.5i (TypeC)	SVPM2-11i (TypeA)	SVPM2-11i (TypeC)	SVPM2-15i (TypeA)	SVPM2-15i (TypeC)
Unit specification	A06B-6134-H201#A	A06B-6134-H201#C	A06B-6134-H202#A	A06B-6134-H202#C	A06B-6134-H203#A	A06B-6134-H203#C
Power PC board	A20B-2101-0020	A20B-2101-0020	A20B-2101-0021	A20B-2101-0021	A20B-2101-0022	A20B-2101-0022
Control PC board	A20B-2101-0012	A20B-2101-0012	A20B-2101-0012	A20B-2101-0012	A20B-2101-0012	A20B-2101-0012
Module PC board	A20B-2902-0670	A20B-2902-0672	A20B-2902-0670	A20B-2902-0672	A20B-2902-0670	A20B-2902-0672
Main power supply 3-phase input	Input voltage	200-240VAC (+10%, -15%) 50/60Hz				
	Input current (50Hz)	26Arms		49Arms		64Arms
	Power supply rating	9KVA		17KVA		22KVA
Control power supply	Input voltage	24VDC±10%				
	Input current	1.5Amax.				
Control method	Sine wave PWM control with Transistor Bridge					
Servo HRV control	HRV2, HRV3					
Rated output current of spindle	29Arms		56Arms		64Arms	
Basic output frequency of spindle	60Hz					
Output frequency range of spindle	1Hz-1KHz					
Rated output current of servo axis	L axis	6.5Arms		6.5Arms		13Arms
	Maxis	6.5Arms		6.5Arms		13Arms
Maximum output current of servo axis	L axis	20A		20A		40A
	M axis	20A		20A		40A
Output frequency range of servo axis	0Hz-334Hz					
Protection function	High Current IPM Abnormal High Voltage of DC Link Low Voltage of DC Link Low Voltage of Control Power Supply Short Time Overload FSSB Communication Error					
Ambient temperature range	0-+55 °C					
Weight	14.8kg					
Dimensions	Outside dimensions	260x380x272				
	Fin dimensions	260x380x100				
Option	AC reactor	A81L-0001-0155			A81L-0001-0156	

Three-axis type (SVPM3)

Item	SVPM3-5.5i (TypeA)	SVPM3-5.5i (TypeC)	SVPM3-11i (TypeA)	SVPM3-11i (TypeC)	SVPM3-15i (TypeA)	SVPM3-15i (TypeC)
Unit specification	A06B-6134-H301#A	A06B-6134-H301#C	A06B-6134-H302#A	A06B-6134-H302#C	A06B-6134-H303#A	A06B-6134-H303#C
Power PC board	A20B-2101-0023	A20B-2101-0023	A20B-2101-0024	A20B-2101-0024	A20B-2101-0025	A20B-2101-0025
Control PC board	A20B-2101-0013	A20B-2101-0013	A20B-2101-0013	A20B-2101-0013	A20B-2101-0013	A20B-2101-0013
Module PC board	A20B-2902-0670	A20B-2902-0672	A20B-2902-0670	A20B-2902-0672	A20B-2902-0670	A20B-2902-0672
Main power supply 3-phase input	Input voltage	200-240VAC (+10%, -15%) 50/60Hz				
	Input current(50Hz)	26Arms		49Arms		64Arms
	Power supply rating	9KVA		17KVA		22KVA
Control power supply	Input voltage	24VDC \pm 10%				
	Input current	1.5Amax.				
Servo HRV control	HRV2, HRV3					
Control method	Sine wave PWM control with Transistor Bridge					
Rated output current of spindle	29Arms		56Arms		64Arms	
Basic output frequency of spindle	60Hz					
Output frequency range of spindle	1Hz-1KHz					
Rated output current of servo axis	L axis	6.5Arms		6.5Arms		13Arms
	M axis	6.5Arms		6.5Arms		13Arms
	N axis	13Arms		13Arms		13Arms
Maximum output current of servo axis	L axis	20Ap		20Ap		40Ap
	M axis	20Ap		20Ap		40Ap
	N axis	40Ap		40Ap		40Ap
Output frequency range of servo axis	0Hz-334Hz					
Protection function	High Current IPM Abnormal High Voltage of DC Link Low Voltage of DC Link Low Voltage of Control Power Supply Short Time Overload FSSB Communication Error					
Ambient temperature	0-+55 °C					
Weight	14.8kg					
Dimensions	Outside dimensions	260x380x272				
	Fin dimensions	260x380x100				
Option	AC reactor	A81L-0001-0155			A81L-0001-0156	

3.2 COOLING FAN MOTOR

Install a cooling fan motor listed below.

Otherwise, make arrangements so that the required air flow can be obtained.

Ordering number		Optional fan	Required air flow
SVPM2-5.5i A06B-6134-H201#*	SVPM3-5.5i A06B-6134-H301#*	A06B-6134-K001 One unit	2 m/s
SVPM2-11i A06B-6134-H202#*	SVPM3-11i A06B-6134-H302#*	A06B-6134-K001 One unit	
SVPM2-15i A06B-6134-H203#*	SVPM3-15i A06B-6134-H303#*	A06B-6134-K001 One unit	

3.3 HOW TO OBTAIN A POWER SUPPLY CAPACITY

- Output capacity -

The output capacity is the sum of the total spindle motor continuous output rating multiplied by a coefficient (1.15) and the servo motor continuous output rating multiplied by a coefficient (0.6).

-Power supply capacity-

SVPM*-5.5i

Power supply capacity (kVA) = output capacity (kW) × 1.64

SVPM*-11i

Power supply capacity (kVA) = output capacity (kW) × 1.55

SVPM*-15i

Power supply capacity (kVA) = output capacity (kW) × 1.47

[How to obtain the input current so units to be installed at the input section can be selected]

Obtain the SVPM input current, using the following expression. Use it as a reference value in selecting a circuit breaker, magnetic contactor, and power cable.

(Margin for selection: 1 to 1.5 times)

$$SVPM \text{ input current (Arms)} = \frac{\text{Power supply capacity (kVA)}}{\sqrt{3} \times \text{nominal power supply voltage (Vrms)}} \times 1.2 \text{ (margin)}$$

(Assume the nominal power supply voltage (Vrms) is usually 200 Vrms.)

3.4 APPLICABLE MOTORS

		Spindle Motor				Servo Motor				
		$\beta 3/10000i$	$\beta 6/10000i$	$\beta 8/8000i$	$\beta 12/7000i$	$\beta 2/4000is$	$\beta 4/4000is$	$\beta 8/3000is$	$\beta 12/3000is$	$\beta 22/2000is$
SVPM2-5.5i A06B-6134-H201*	Spindle	O								
	Servo L axis					O	O	O		
	Servo M axis					O	O	O		
SVPM2-11i A06B-6134-H202*	Spindle	**	O	O						
	Servo L axis					O	O	O		
	Servo M axis					O	O	O		
SVPM2-15i A06B-6134-H203*	Spindle	**	**	**	O					
	Servo L axis					**	**	**	O	O
	Servo M axis					**	**	**	O	O
SVPM3-5.5i A06B-6134-H301*	Spindle	O								
	Servo L axis					O	O	O		
	Servo M axis					O	O	O		
	Servo N axis					**	**	**	O	O
SVPM3-11i A06B-6134-H302*	Spindle	**	O	O						
	Servo L axis					O	O	O		
	Servo M axis					O	O	O		
	Servo N axis					**	**	**	O	O
SVPM3-15i A06B-6134-H303*	Spindle	**	**	**	O					
	Servo L axis					**	**	**	O	O
	Servo M axis					**	**	**	O	O
	Servo N axis					**	**	**	O	O



CAUTION

** Combining with this motor requires changing the motor control parameter.

An incorrect parameter setting may damage the motor.

3.5 CIRCUIT BREAKER, MAGNETIC CONTACTOR, AND AC REACTOR

3.5.1 AC Line Filter and Magnetic Contactor

The ratings of the circuit breakers and magnetic contactor are determined by the specifications of the power supply module used. The ordering specification drawing numbers and specifications of circuit breakers and magnetic contactors are listed below.

When the user prepares circuit breakers and a magnetic contactor, use those that satisfy the specifications listed below.

- Specifications of circuit breakers and magnetic contactors

SVPM name	Circuit breaker 1	Circuit breaker 2	Magnetic contactor
SVPM*-5.5i (*: 2 or 3)	30A	5A	30A
SVPM*-11i (*: 2 or 3)	55A		55A
SVPM*-15i (*: 2 or 3)	70A		70A

NOTE

- 1 For the locations of the circuit breakers and magnetic contactor, see Section 1.2, "CONFIGURATION".
- 2 Select the rated voltages of the circuit breakers according to the power supply voltage.

- Recommended products

Manufactured by Fuji Electric Co., Ltd.

SVPM name	Circuit breaker 1	Circuit breaker 2	Magnetic contactor
SVPM*-5.5i (*: 2 or 3)	EA103B/50	EA33/5	SC- N 1
SVPM*-11i (*: 2 or 3)	EA103B/60		SC- N 2
SVPM*-15i (*: 2 or 3)	EA103B/75		SC- N2S

NOTE

For details, refer to the brochure supplied by Fuji Electric Co., Ltd.
Note that the coil voltage specification of the magnetic contactor varies depending on the power supply voltage and frequency used.

- Ordering specification drawing number of circuit breaker 1

Type	Applicable model	Ordering specification drawing No.	Circuit breaker specification	Circuit breaker cover specification
Option	SVPM*-5.5i (*: 2 or 3)	A06B-6077-K102	Fuji Electric, EA103B/50	Fuji Electric, BZ-TB20B-3
	SVPM*-11i (*: 2 or 3)	A06B-6077-K103	Fuji Electric, EA103B/60	Fuji Electric, BZ-TB20B-3
	SVPM*-15i (*: 2 or 3)	A06B-6077-K104	Fuji Electric, EA103B/75	Fuji Electric, BZ-TB20B-3

- Ordering specification drawing number of circuit breaker 2

Type	Applicable model	Ordering specification drawing No.	Circuit breaker specification	Circuit breaker cover specification
Option	For control power supply (common to all SVPM models)	A06B-6077-K106	Fuji Electric, EA33/5	Fuji Electric, BZ-TB10B-503

- Ordering specification drawing number of magnetic contactor

Type	Applicable model	Ordering specification drawing No.	Magnetic contactor specification	Magnetic contactor cover specification
Option	SVPM*-5.5i (*: 2 or 3)	A06B-6077-K122	Fuji Electric, SC-1N	Fuji Electric, SZ-1N/T
	SVPM*-11i (*: 2 or 3)	A06B-6077-K123	Fuji Electric, SC-2N	Fuji Electric, SZ-1N/T
	SVPM*-15i (*: 2 or 3)	A06B-6077-K124	Fuji Electric, SC-2SN	Fuji Electric, SZ-2SN/T

NOTE

The coil voltage specification of the magnetic contactor is 200 VAC.

3.5.2 AC Reactor

Type	Applicable model	Ordering specification drawing No.
Basic	SVPM*-5.5i (*: 2 or 3)	A81L-0001-0155
	SVPM*-11i (*: 2 or 3)	
	SVPM*-15i (*: 2 or 3)	A81L-0001-0156

3.6 SPINDLE AXIS TYPES (#A AND #C) AND APPLICABLE SENSORS

Two models (#A and #C) are available for each sensor for spindles. The following table lists combinations of applicable sensors and functions.

			Configuration						Remarks
			1	2	3	4	5	6	
Spindle system configuration	Ordering number A06B-6134-H***#A, #C	#A (TYPE A)	○	○	○	○			
		#C (TYPE C)					○	○	
	Sensor on the motor	Mi sensor	○		○	○			
		MZi sensor		○					
		Without sensor					○	○	
	Sensor on the spindle	α position coder			○			○	*3
		External one-rotation				○			*3
Function	Rigid tapping		○ *1	○	○	○ *2		○	
	Orientation by a position coder			○	○			○	
	Orientation by the external one-rotation signal					○ *2			*5
	Spindle synchronization	Velocity synchronization	○ *2	○	○	○ *2		○	*4
		Phase synchronization		○	○			○	*4
	Threading			○	○			○	
	Cs contouring control			○ *6	○ *7				

- *1 The spindle and motor must be interconnected with a timing belt or gear. No orientation is available to adjust the tapping start position.
- *2 The spindle and motor must be interconnected with a timing belt or gear.
- *3 The spindle and sensor must be interconnected in one-to-one connection mode.
- *4 Two motor amplifiers are required.
- *5 Note that the stop position moves by a backlash between the spindle and motor because of the theory of operation.
- *6 This function is enabled on the machine that the spindle motor is directly connected to a spindle.
- *7 The resolution of position detection is 4096 p/rev.

Other spindle axis functions

○ : Applicable

	#A	#C	Remarks
Analog output of load meter and speedometer	○		Connector JY1
Analog output of either load meter or speedometer		○	Connector JY1
Analog override input	○	○	Connector JY1

3.7 DERATING

Derating

Consider derating as shown below, according to ambient temperatures.

Target models: All SVPM models

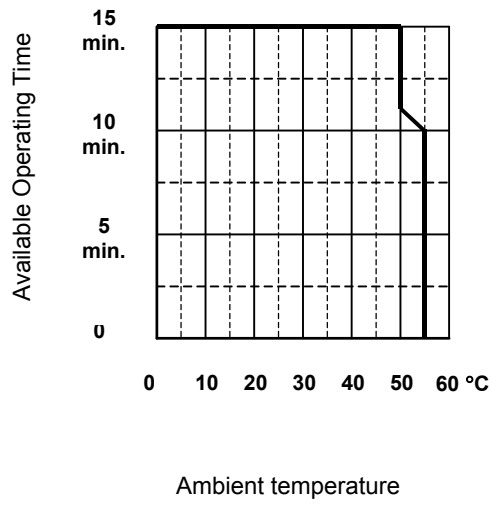

4

ORDERING INFORMATION

Refer to the order list (B-65321EN).

5

POWER SUPPLY

5.1 INPUT POWER SUPPLY

5.1.1 Three-phase Input Power Supply for Motor Power

- Nominal rated voltage: 200 to 240 VAC
- Allowable voltage fluctuation: -15% to +10%
- Frequency: 50/60 Hz
- Allowable frequency fluctuation: ± 2 Hz
- Power supply impedance: Voltage fluctuation caused by load (at maximum output) not to exceed 7%
- Power supply unbalance: Within $\pm 5\%$ of the rated voltage

NOTE

The allowable voltage fluctuation is a change observed for several minutes. It is not a continuous change.

- (1) If the power supply impedance is high, and the voltage fluctuation exceeds the specification, an SVPM alarm (DC link low voltage alarm or DC link overvoltage alarm) or a motor output drop may result.

Use an appropriate power supply of which input voltage fluctuation during motor acceleration does not exceed 7%.

[Checking the power supply impedance]

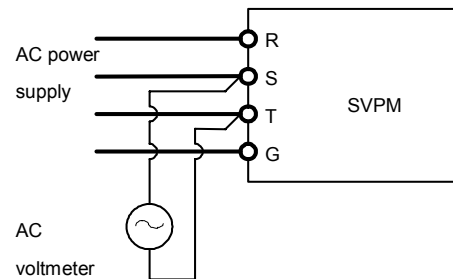

$$\frac{|E0 - E1|}{E0} \times 100(\%) < 7(\%)$$

E0: Voltage under no load

E1: Voltage at maximum output (power running and regeneration)

- (2) Input the power supply to the SVPM control circuit (power supply input of CXA2C) before turning on the CNC or within 500 ms after turning on the CNC.
- (3) Because a capacitor for power-factor improvement may affect power supply regeneration, it is recommended that such a capacitor be not installed.
- (4) The rated output of the motor is guaranteed on the rated input voltage. When the input voltage changes, the rated output may not be observed even if the change is within the allowable fluctuation range.

5.1.2 Single-phase Input for Control Power

Be sure to use a stabilized power supply as the 24-V power supply for amplifiers. The 24-V power supply for motor brakes cannot be shared.

- Nominal rated voltage: 24VDC
- Allowable voltage fluctuation:
 $\pm 10\%$ (including momentary variations)
- Power supply ratings: 1.5A (per amplifier)

For the specification and circuit configuration of the external 24-VDC power supply, see "POWER SUPPLY" in Part I, "SVM".

5.2 POWER TRANSFORMER FOR EXPORTS

When a SVPM of the 200V input series is used in an area where the input voltage is not within the range of 200 to 230VAC, a power transformer is required. The ordering drawing numbers and specifications of power transformers manufactured by FANUC are listed below. When other than a FANUC power transformers is to be prepared by the user, it must satisfy the transformer specifications indicated Section 2.1.

Ordering drawing numbers of power transformers manufactured by FANUC

Ordering number	Name	Remarks
A06B-6052-J001	For SVPM*-5.5i (*:2 or 3)	Primary 380/415/460VAC Secondary 200VAC
A06B-6044-J006	For SVPM*-11i (*:2 or 3)	
A06B-6044-J007	For SVPM*-15i (*:2 or 3)	

- Specifications of power transformers manufactured by FANUC

Power transformer for SVPM

Model	SVPM*-5.5i	SVPM*-11i	SVPM*-15i
Ordering drawing number	A06B-6052-J001	A06B-6044-J006	A06B-6044-J007
FANUC drawing number	A80L-0001-0496	A80L-0001-0313	A80L-0001-0314
Rated capacity	10kVA	20kVA	30kVA
Rated primary voltage	380/415/460VAC 230VAC (The secondary is used as an autotransformer.) +10% -15%, 50/60±1Hz, 3φ		
Rated primary current	15A (at 380V) 14A (at 415V) 13A (at 460V)	30A (at 380V) 28A (at 415V) 25A (at 460V)	46A (at 380V) 42A (at 415V) 38A (at 460V)
Rated secondary voltage	AC200/220/230V		
Rated secondary current	29A	58A	87A
Voltage regulation at the secondary	5%		
Voltage deviation at the secondary	±3%		
Connection	Y-Y connection		
Insulation	Class H (maximum allowable temperature : 180°C)		
Ambient temperature	0 to 45°C		
Allowable temperature rise	135deg		
Relative humidity	Max. 95%RH		
Type	Dry type, natural air cooling type		
Dielectric withstand voltage	2000VAC, for 1 minute		
Weight	Max. 61kg	Max. 115kg	Max. 165kg
Outline drawing	Fig. 8.1.4(a)	Fig. 8.1.4(b)	Fig. 8.1.4(c)
Connection diagram			

- Connecting a power transformer

Power transformers must be set according to the supply voltage used.

(a) Connection points of power transformers for SVPM*-5.5i, SVPM*-11i, and SVPM*-15i

Supply voltage	Connection points at the primary	Remarks
380VAC	R - R1, S - S1, T - T1(380-V tap))	
400VAC	R - R1, S - S1, T - T1(380-V tap)	
415VAC	R - R2, S - S2, T - T2(415-V tap)	
440VAC	R - R2, S - S2, T - T2(415-V tap)	
460VAC	R - R3, S - S3, T - T3(460-V tap)	
480VAC	R - R3, S - S3, T - T3(460-V tap)	

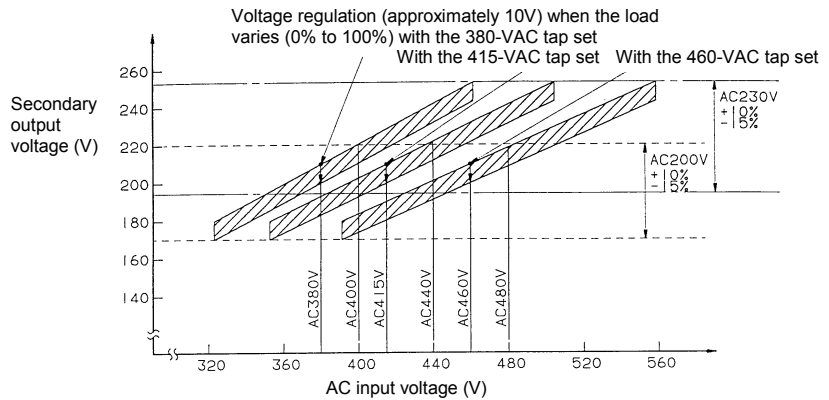

⚠ CAUTION

- 1 When installing a transformer in a cabinet, be careful to ensure that the transformer does not thermally affect other equipment. For example, separate the transformer from the other equipment.
- 2 When installing a transformer outside the cabinet, make sure that the transformer is not directly exposed to cutting chips or coolant.
- 3 If there is a possibility of the transformer falling, secure the transformer with bolts or similar.

6

INSTALLATION CONDITIONS AND NOTES

6.1 ENVIRONMENTAL CONDITIONS

See Chapter 6 in Part I “SVM”.

6.2 Selecting a Ground-Fault Circuit Interrupter

See Chapter 6 in Part I “SVM”.

6.3 NOISE PROTECTION

See Chapter 6 in Part I “SVM”.

6.4 INSTALLING LIGHTNING SURGE ABSORBERS

At the power input of the power magnetics cabinet, install a surge absorber between the power lines and between each power line and a ground to protect the unit from a voltage surge caused by lightning. How to install the surge absorber is shown below.

(1) Surge absorber for three-phase input

When using an integrated lightning surge absorber between the power lines and between each power line and a ground

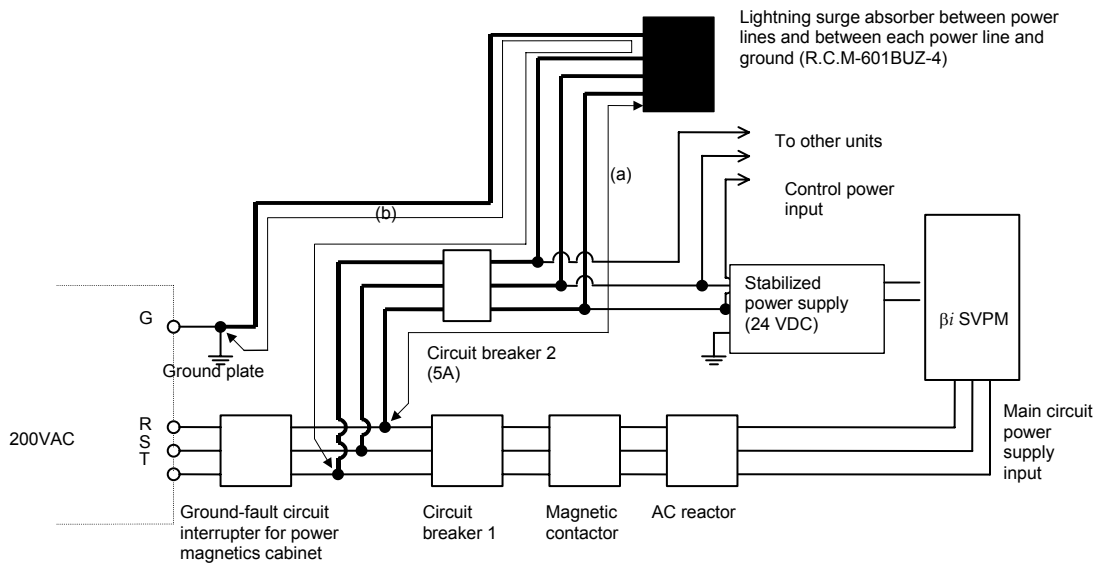

When using separate lightning surge absorbers between the power lines and between each power line and a ground

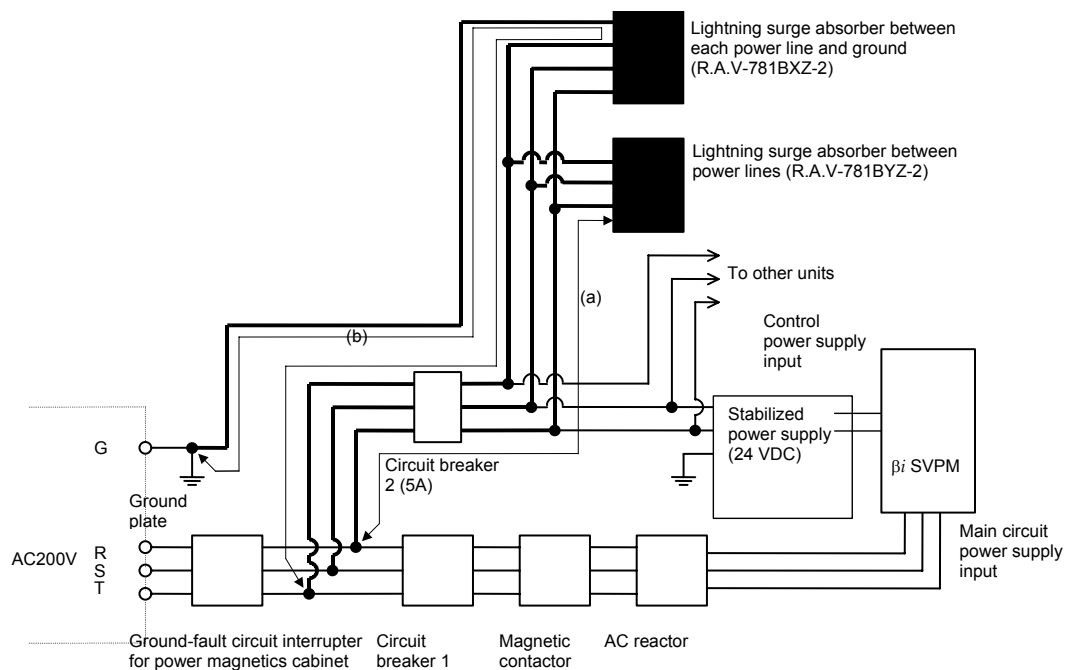

⚠ WARNING

- 1 Make the wires shown with thick line in the above diagram as short as possible in order to increase the effect of the lightning surge absorber.
Wire Cross section : At least 2mm²
Length : Keep the total wire length (a+b) to within 2m, where a = length of wire used to connect lightning surge absorber (1) b = length of wire used to connect lightning surge absorber (2)
- 2 When performing a dielectric strength test by applying an overvoltage (such as 1000 or 1500 VAC) to a power line, remove lightning surge absorber (2) so that it will not operate.
- 3 The circuit protector (5A) is intended to protect the lines if a lightning surge absorber is damaged due to a surge that is higher than the maximum allowable voltage of the surge absorber.
- 4 Usually, no current flows through the lightning surge absorbers. So the circuit protector (5A) may be used also for other sections (such as power supply module control power and spindle motor fan power).

The following table lists commercially available lightning surge absorbers.

Table 6.4(a) Lightning surge absorbers (not complying with the relevant standards)

Lightning surge absorber	Manufacturer's specification Okaya Electric Industries	Clamp voltage [V]±10%	Maximum allowable surge current 8/20µsec [A]	Maximum allowable surge voltage 1.2/50µsec [V]	Maximum allowable circuit voltage [Vrms]
<1>	R·A·V-781BYZ-2	783	1000	12000	300
<2>	R·A·V-781BXZ-2A	783	1000	12000	300

Table 6.4(b) Lightning surge absorbers (complying with the relevant standards)

Lightning surge absorber	Manufacturer's specification Okaya Electric Industries	Clamp voltage [V]±10%	Maximum allowable surge current 8/20µsec [A]	Maximum allowable surge voltage 1.2/50µsec [V]	Maximum allowable circuit voltage [Vrms]
<1>	R·A·V-781BYZ-2	783	1000	12000	300
<2>	R·A·V-781BXZ-4	783	1000	12000	300

7

PROTECTIVE GROUNDING

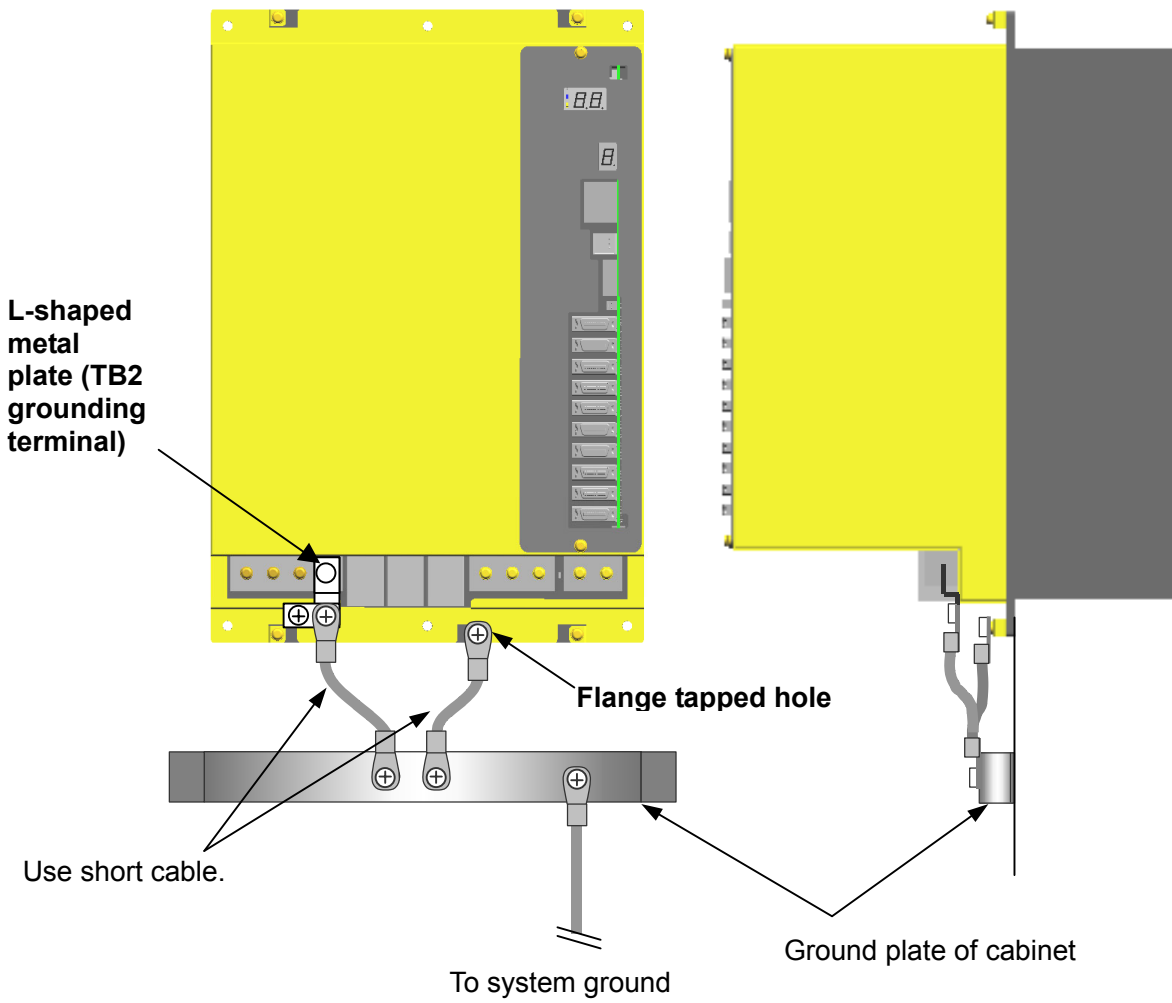

8

EXTERNAL DIMENSIONS / PANEL CUT-OUT DRAWINGS / MAINTENANCE AREA

8.1 EXTERNAL DIMENSIONS

8.1.1 External Dimensions of SVPM

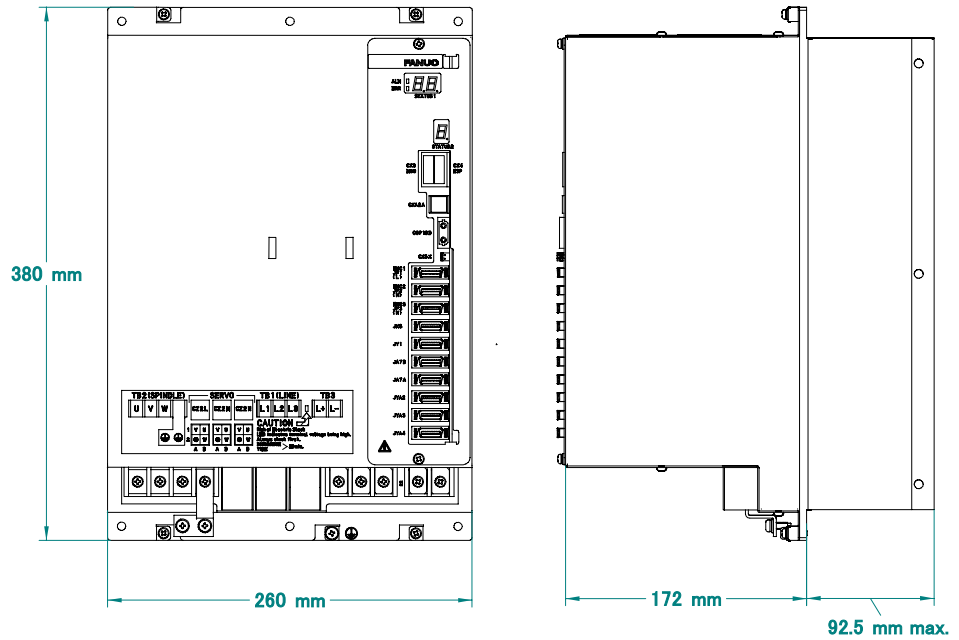

Weight : 14.8 kg

8.1.2 External Dimensions of Fan Unit (A06B-6134-K001)

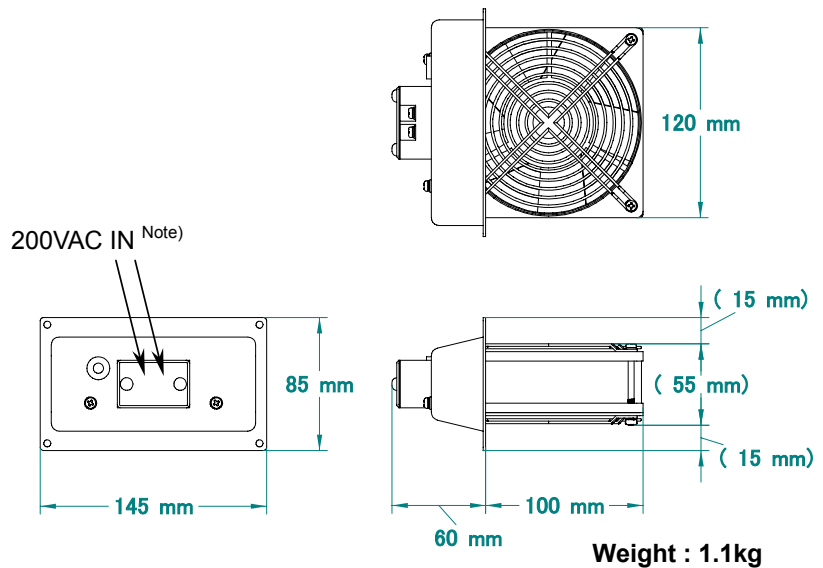

Weight : 1.1kg

NOTE

Use a 2-A fuse or circuit breaker to prevent a motor burnout.

8.1.3 AC Reactor Unit

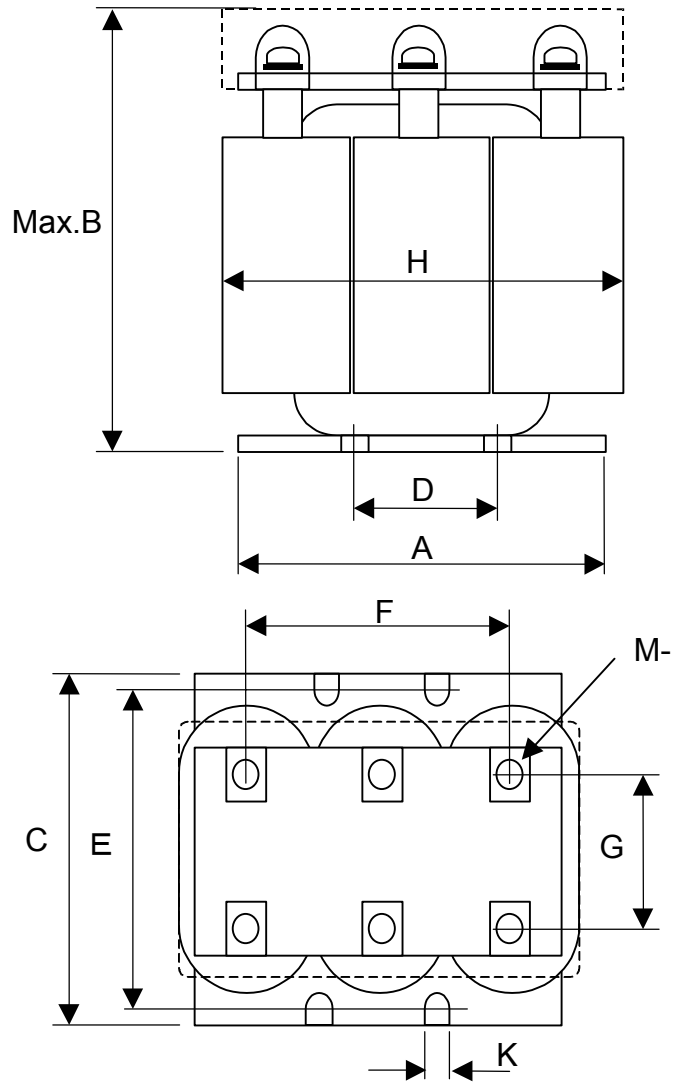

Applicable model	A	B	C	D	E	F	G	H	K	M-
For SVPM-5.5i, 11i	135	155	82	50	65	89	48	135	5	M5
For SVPM-15i	135	155	108	42	95	84	66	135	7.2	M5

8.1.4 Power Transformer

(a) For SVPM-5.5i (A06B-6052-J001)

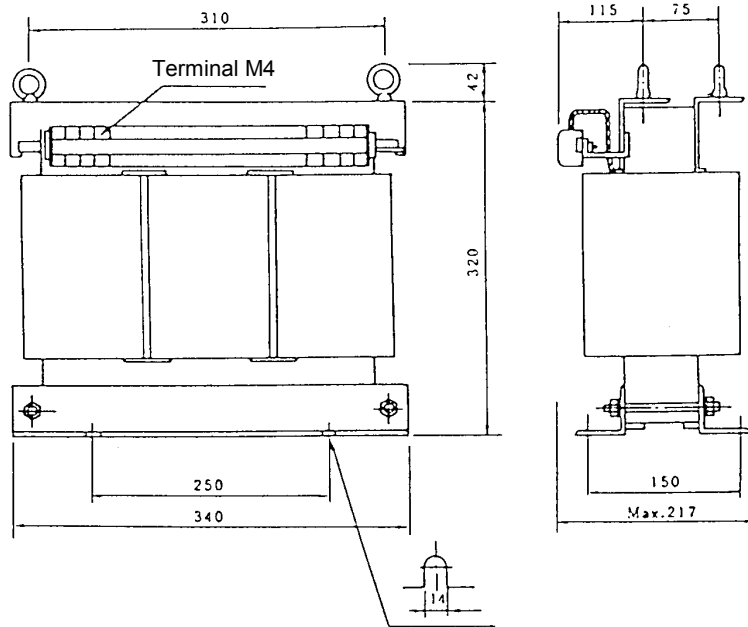

Outline Drawing of Power Transformer with no Cover

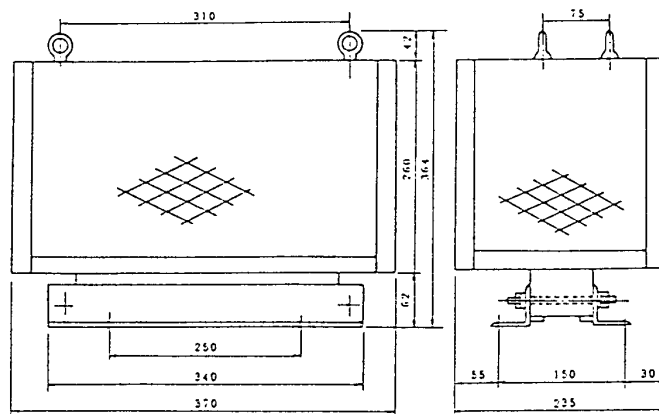

Outline Drawing of Power Transformer with Cover

NOTE

The four side panels are all meshed, while the top is a solid plate.

(b) For SVPM-11i (A06B-6044-J006)

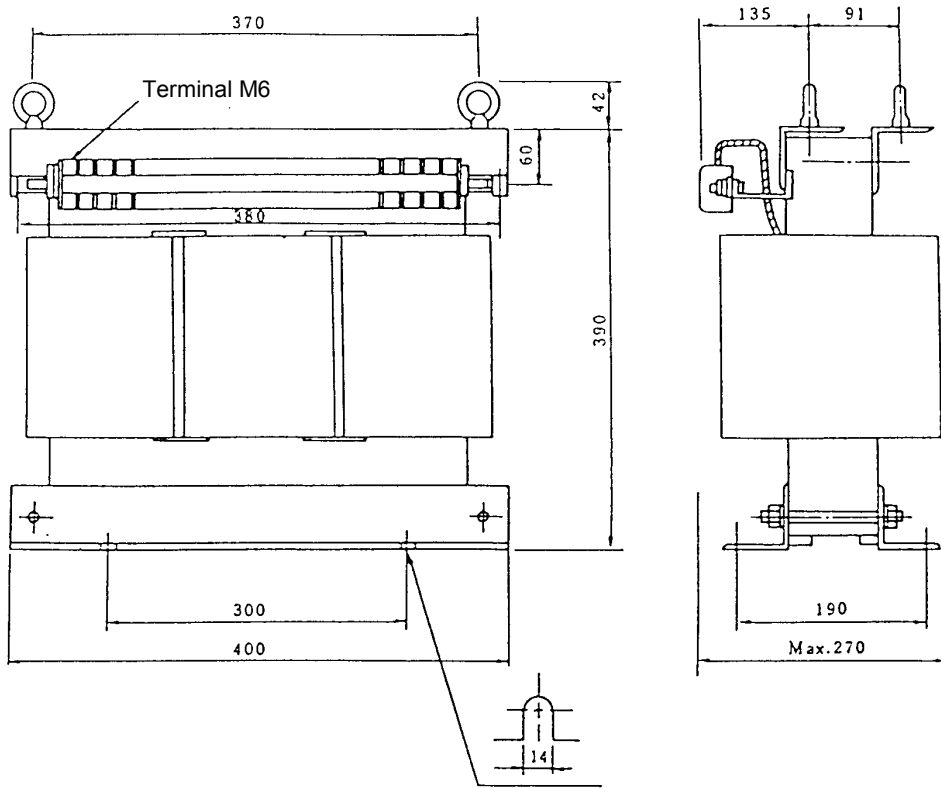

Outline Drawing of Power Transformer with no Cover

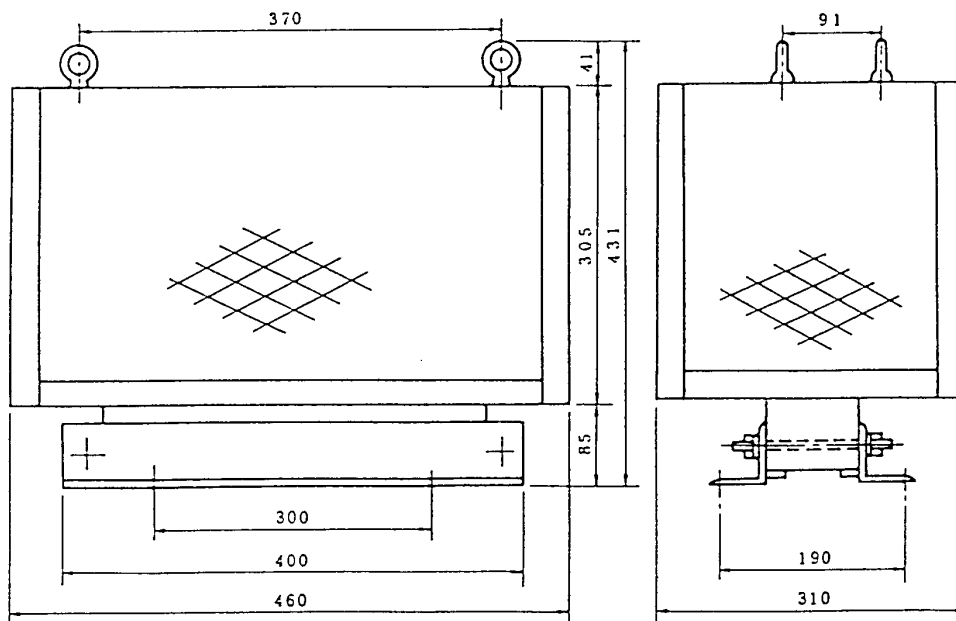

Outline Drawing of Power Transformer with Cover

NOTE
The four side panels are all meshed, while the top is a solid plate.

(c) For SVPM-15i (A06B-6044-J007)

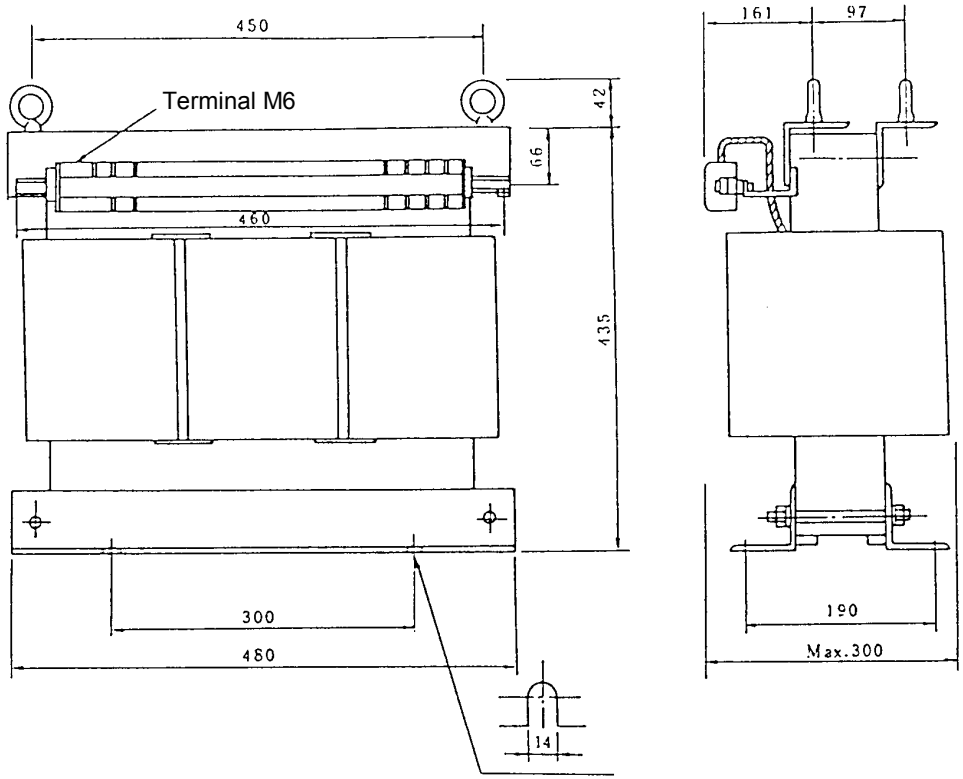

Outline Drawing of Power Transformer with no Cover

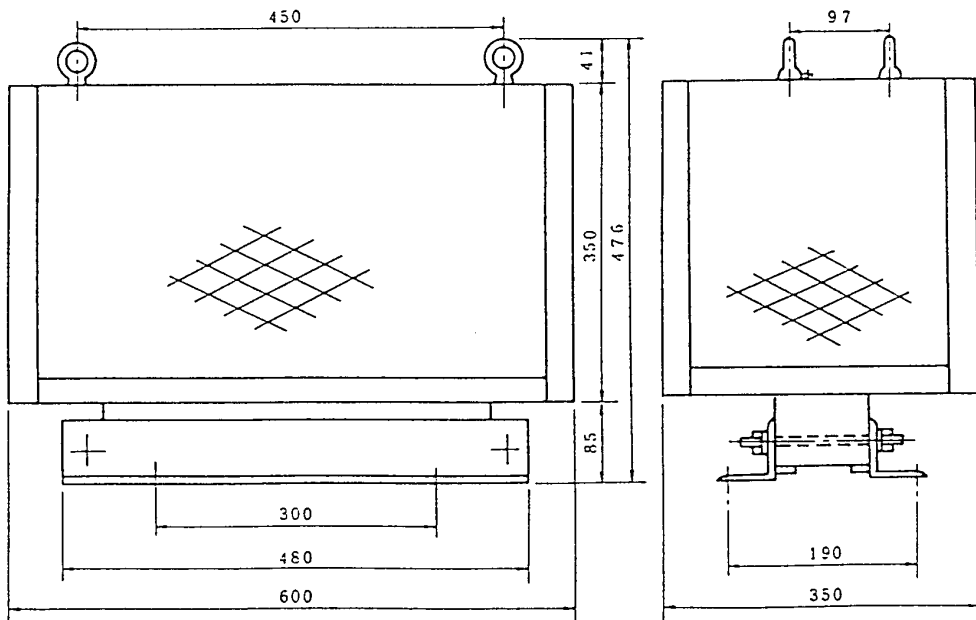

Outline Drawing of Power Transformer with Cover

NOTE
The four side panels are all meshed, while the top is a solid plate.

8.1.5 Circuit Breaker

Ordering drawing number	A	B	C	D	E	M ₁ -	F	G	H	I	J	K	L	M ₂ -	N	Mounting
A06B-6077-K102 (For SVPM*-5.5i)	75	50	190	115	130	M8	17	80	56	49	φ8	φ5	110	M4	25	2 positions (1)
A06B-6077-K103 (For SVPM*-11i)																
A06B-6077-K104 (For SVPM*-15i)																

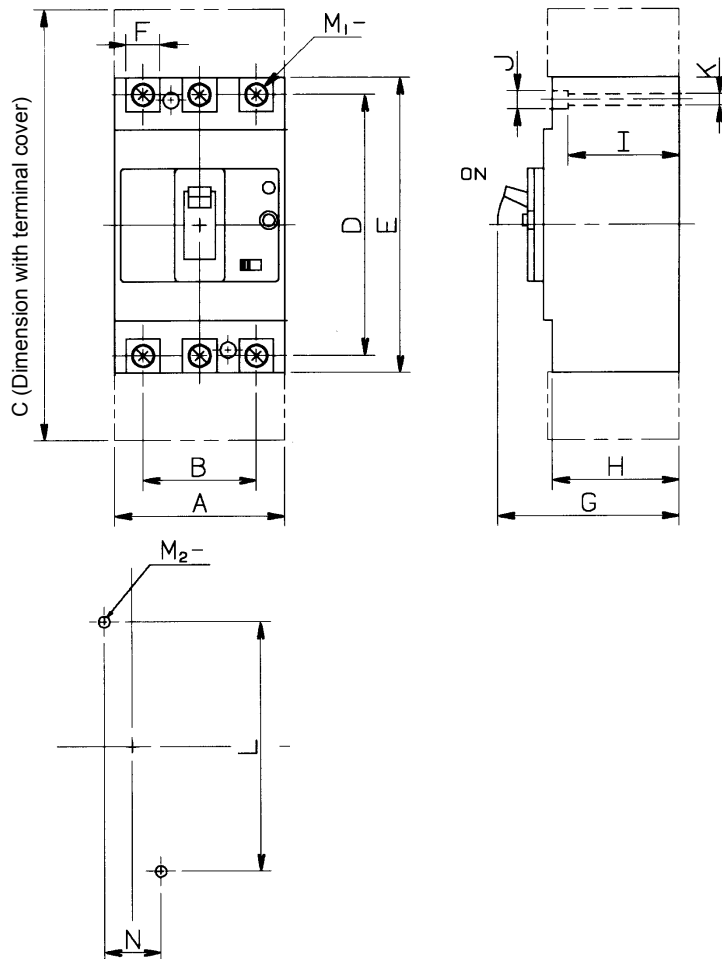

Dimensions for mounting holes

8.1.6 Magnetic Contactors

(a) A06B-6077-K122, A06B-6077-K123

(Dimensions with cover for protecting live parts)

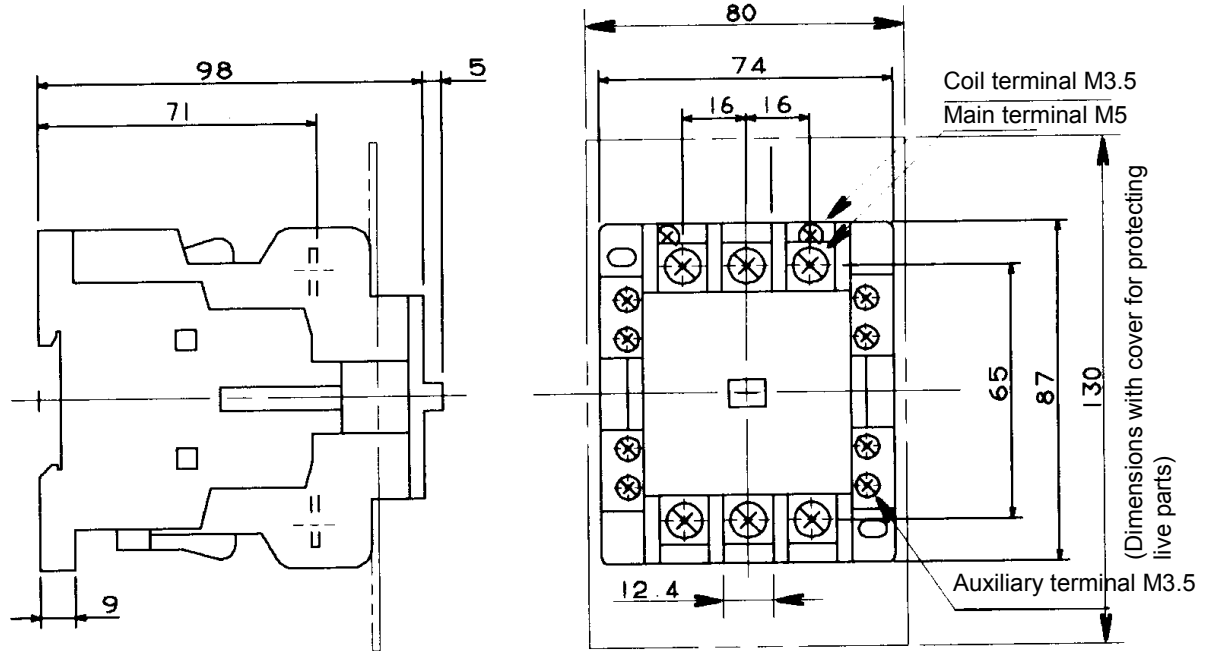

Dimensions for drilling mounting holes

Ordering drawing number	Fuji Electric part number		Operation coil voltage	Auxiliary contact structure	Weight
	Body	Cover			
A06B-6077-K122 (for SVPM*-5.5i)	SC-1N	SZ-1N/T	200V/50Hz	2a2b	0.68Kg
A06B-6077-K123 (for SVPM*-11i)	SC-2N	SZ-1N/T	200-220V/60Hz		0.68Kg

A06B-6077-K124

(Dimensions with cover for protecting live parts)

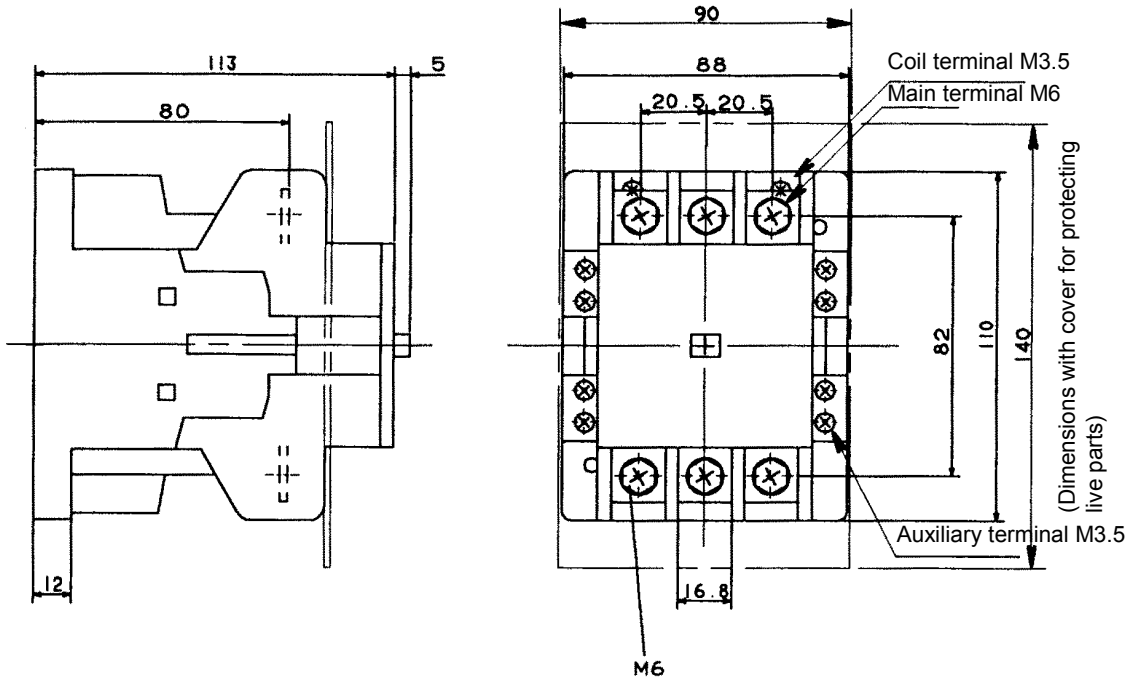

Dimensions for drilling mounting holes

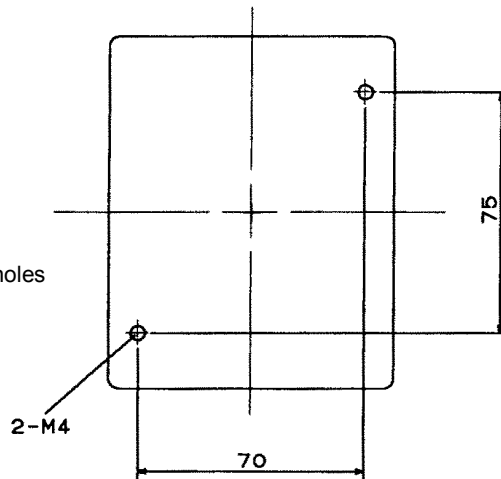

Ordering drawing number	Fuji Electric part number		Operation coil voltage	Auxiliary contact structure	Weight
	Body	Cover			
A06B-6077-K124 (for SVPM*-15i)	SC-2SN	SZ-2SN/T	200V/50Hz 200-220V/60Hz	2a2b	1.3Kg

8.1.7 Lightning Surge Protector

(a) A06B-6077-K144

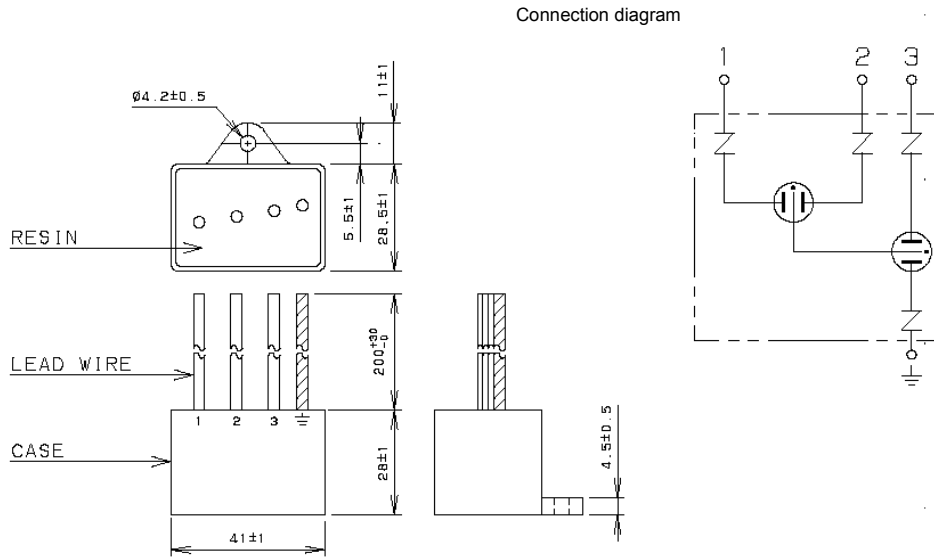

Specification	Rated voltage	AC discharge start voltage	Clamp voltage	Surge withstand current	Surge withstand voltage	Maximum surge discharge start voltage
R-C-M-601BUZ-4	250VAC	560VAC $\pm 20\%(U_a)$	2000V $\pm 10\%(V_{1.0})$	2500A (8/20 μ S)	20kV (1.2/50 μ S)	2kV (1.2/50 μ S)

8.2 PANEL CUT-OUT DRAWINGS

Panel cut-outs that apply when a FANUC fan unit (A06B-6134-K001) is used and when not used are shown below. A fan unit can be placed either on top of or below the servo amplifier.

NOTE

- 1 Attach the accompanying gasket around the panel cut-out to prevent oil and dust from getting into it.
- 2 Reinforce the right and left sides of the panel cut-out in the power magnetics cabinet by using fittings such as angles to maintain satisfactory contact between the power magnetics cabinet and the amplifier.
- 3 Placing a FANUC fan unit on top of the servo amplifier requires installing a duct. Refer to the "Example Duct Structure for Using a FANUC Fan Unit (A06B-6134-K001)" for descriptions about the structure of the duct.
- 4 Placing a FANUC fan unit below the servo amplifier does not require installing a duct. If no FANUC fan unit is used, the user is requested to install a fan motor that can generate an air flow of at least 2 m/s at the heat sink.

(1) When no FANUC fan unit is used

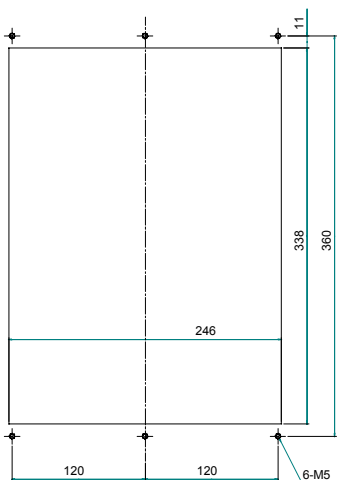

(2) When one FANUC fan unit is used (placed on top of the servo amplifier)

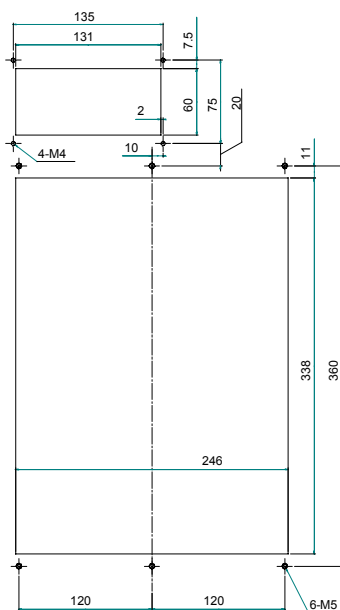

(3) When two FANUC fan units are used (placed on top of the servo amplifier)

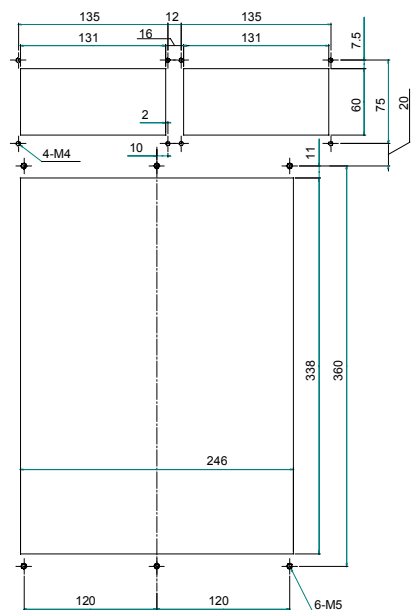

(4) When one FANUC fan unit is used
(placed below the servo amplifier)

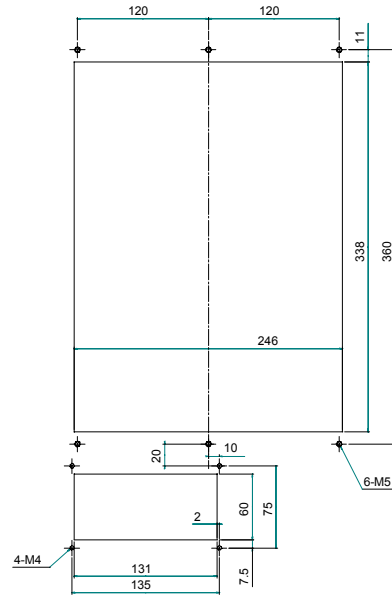

(5) When two FANUC fan units are used
(placed below the servo amplifier)

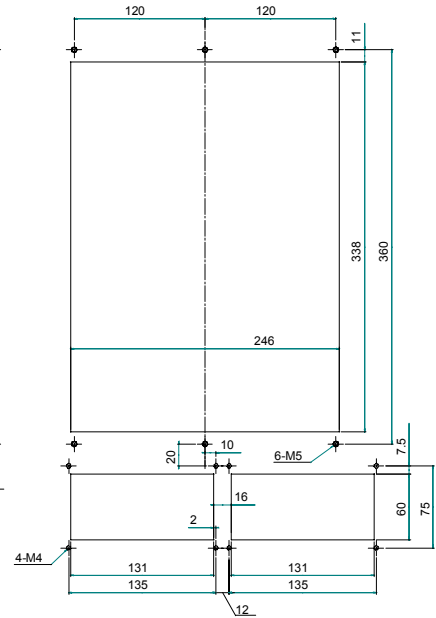

8.3 MAINTENANCE AREA

(1) When no fan unit is used

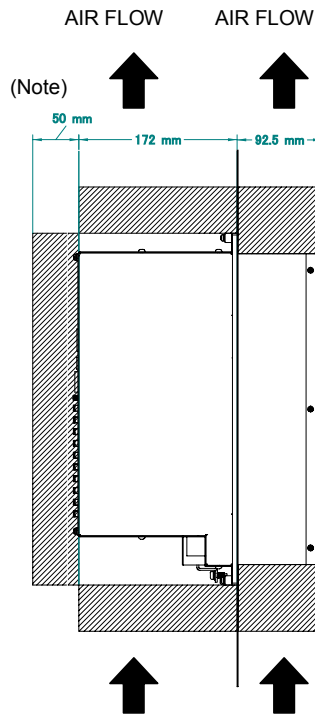
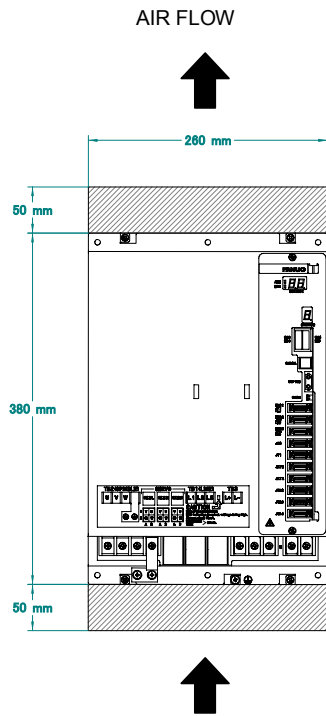

(NOTE) When a right-angle type cable connector is used (+30 mm when a straight type cable connector is used)

(2) When a fan unit used (placed on top of the servo amplifier)

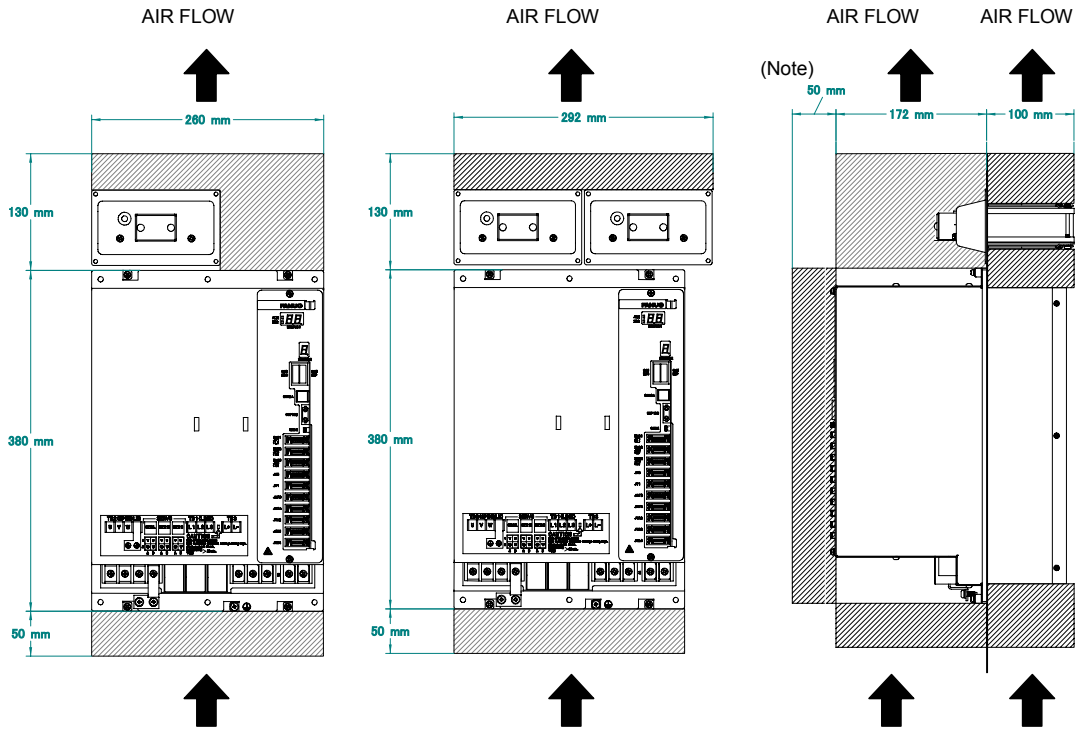

(NOTE) When a right-angle type cable connector is used (+30 mm when a straight type cable connector is used)

(3) When a fan unit used (placed below the servo amplifier)

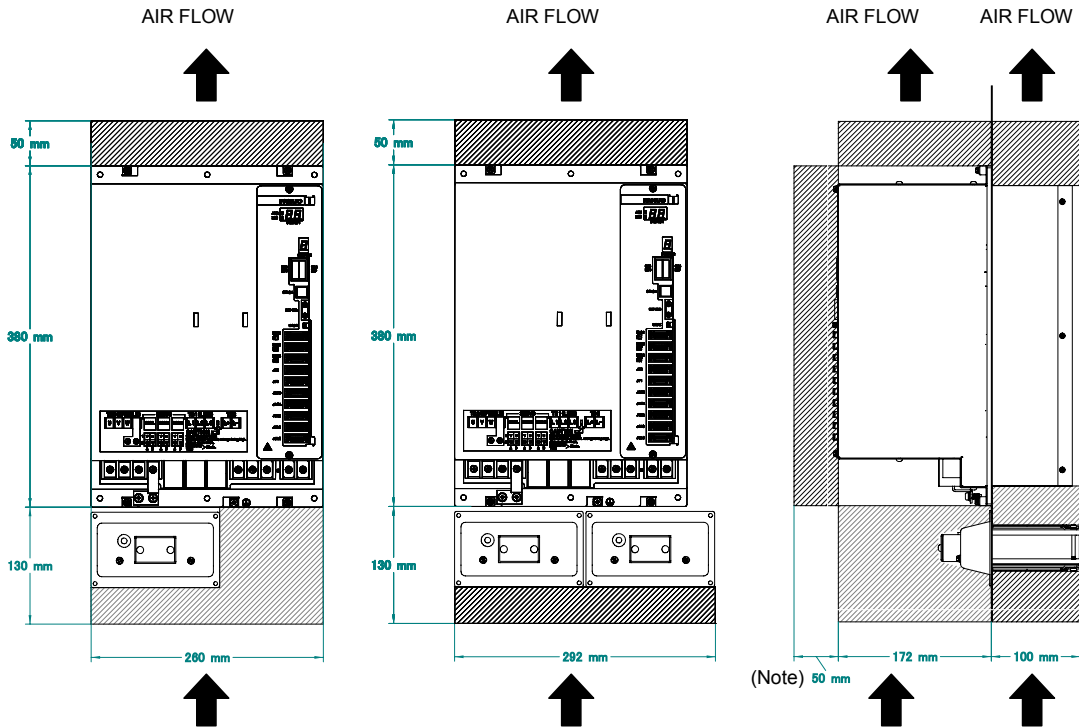

(NOTE) When a right-angle type cable connector is used (+30 mm when a straight type cable connector is used)

8.4 DUCT

Shown below is an example duct structure where a FANUC fan unit (A06B-6134-K001) is used.

NOTE

- 1 Install a duct having the shape shown below between the fan unit and heat sink to provide a ventilation flue.
- 2 Weld the duct to the cabinet.
- 3 If the fan unit is placed below the servo amplifier, no duct is needed.

(1) When one fan unit is used

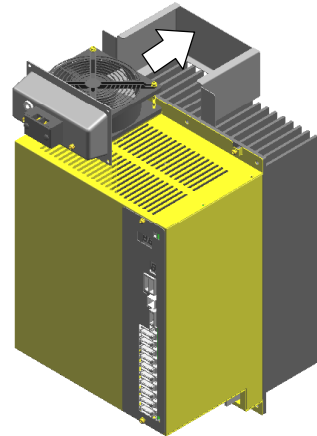
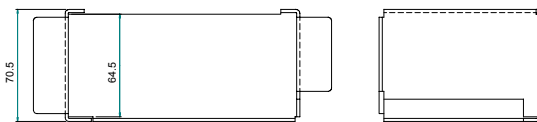
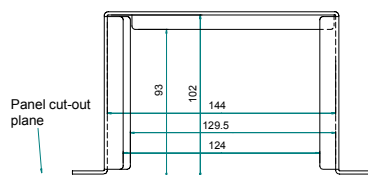

(2) When two fan units are used

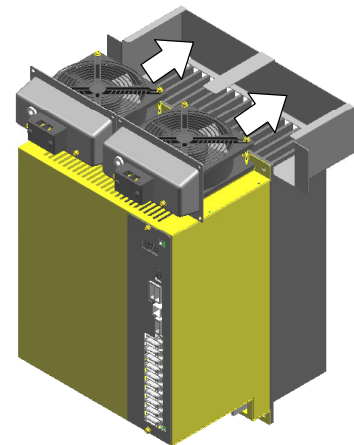
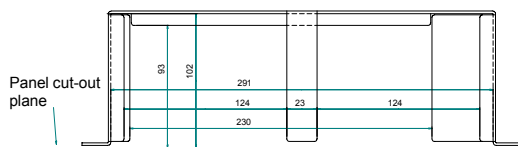

How to mount a fan unit (A06B-6134-K001)

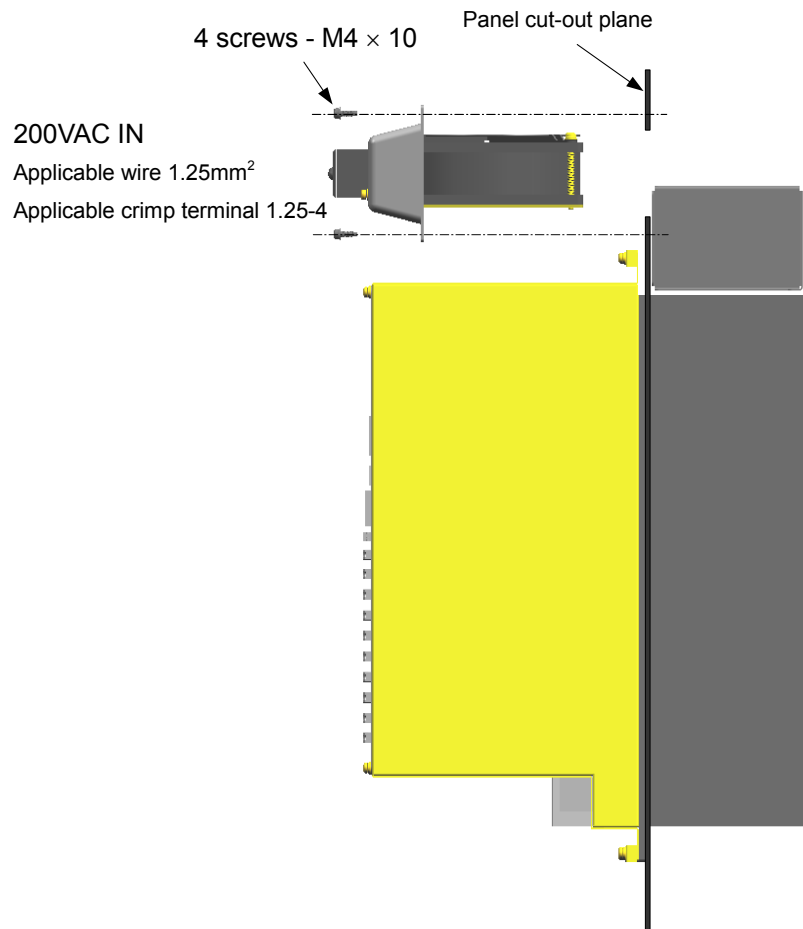

9

TOTAL CONNECTION DIAGRAM

9.1 CONNECTION DIAGRAM

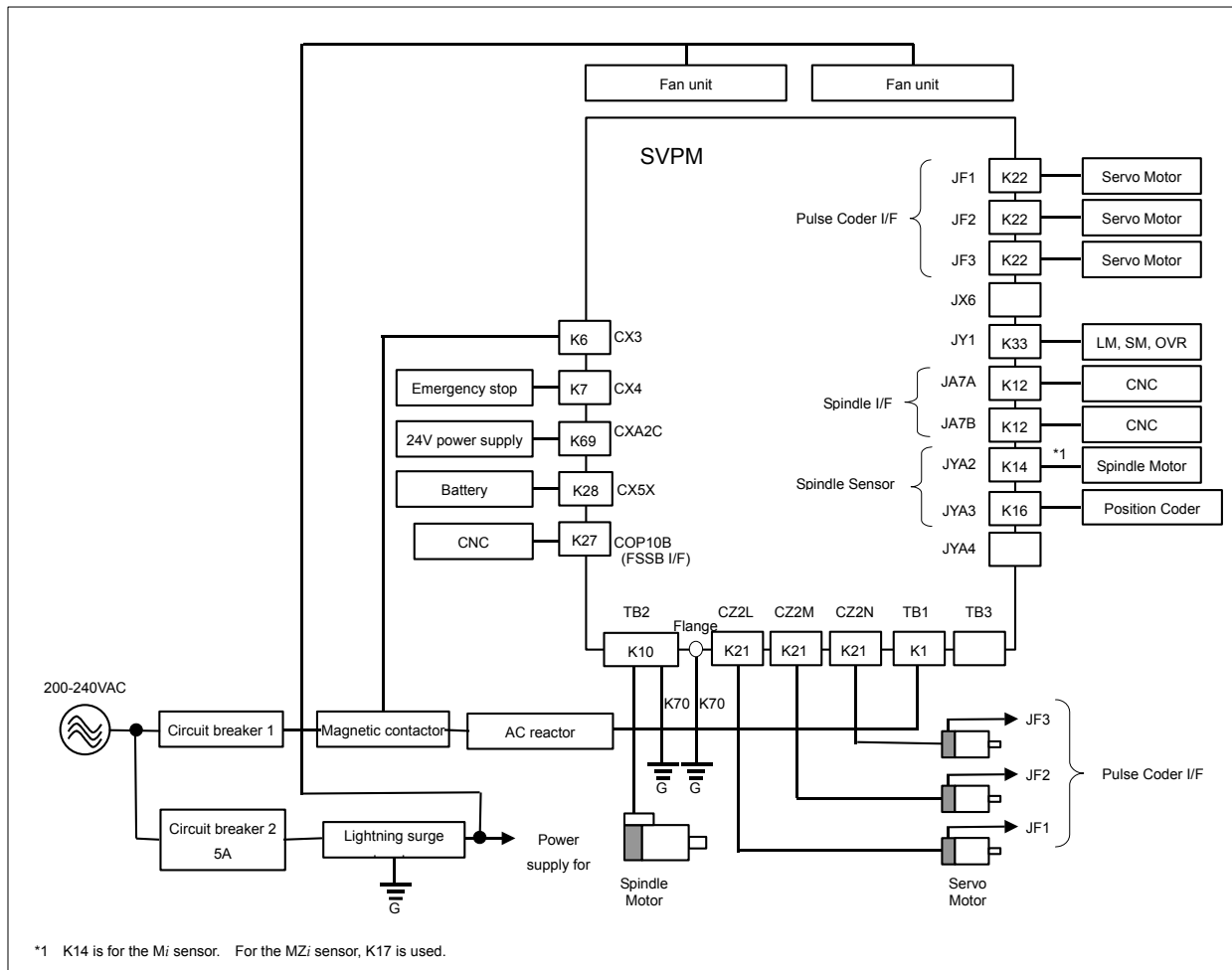

NOTE

- 1 Always install the circuit breakers, magnetic contactor, and AC reactor.
- 2 To protect the equipment from lightning surge voltages, install a lightning surge absorber across each pair of power lines and across each power line and the grounding line at the power inlet of the power magnetics cabinet.
- 3 Be sure to connect the grounding terminal (G) on TB2 to a substantial ground.

9.2 CONNECTOR LOCATION

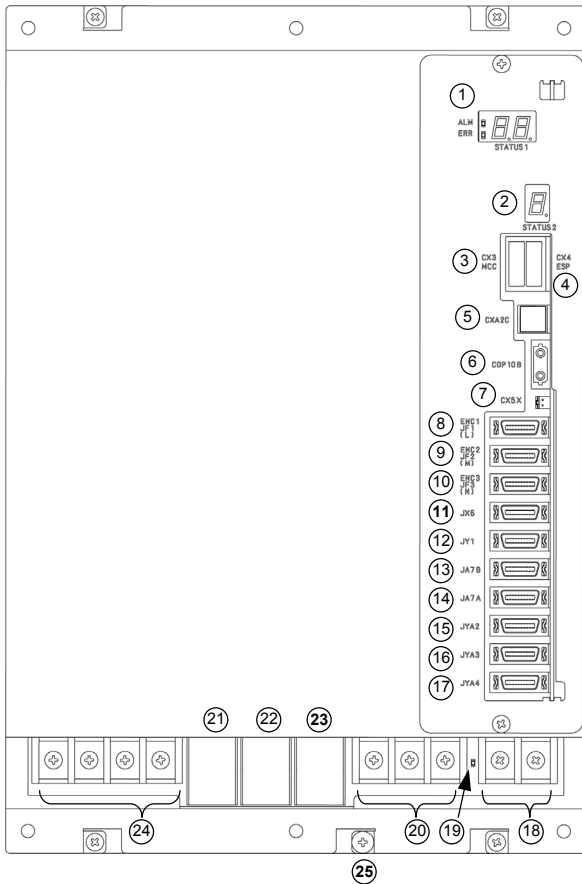

No.	Name	Remarks
1	STATUS1	Status LED : spindle
2	STATUS2	Status LED : servo
3	CX3	Main power MCC control signal
4	CX4	Emergency stop signal (ESP)
5	CXA2C	24VDC power input
6	COP10B	Servo FSSB I/F
7	CX5X	Absolute Pulsecoder battery
8	JF1	Pulsecoder : L axis
9	JF2	Pulsecoder : M axis
10	JF3	Pulsecoder : N axis
11	JX6	Power outage backup module
12	JY1	Load meter, speedometer, analog override
13	JA7B	Spindle interface input
14	JA7A	Spindle interface output
15	JYA2	Spindle sensor M_i , M_zi
16	JYA3	α position coder
17	JYA4	External one-rotation signal
18	TB3	DC link terminal block
19		DC link charge LED (Warning)
20	TB1	Main power supply connection terminal board
21	CZ2L	Servo motor power line : L axis
22	CZ2M	Servo motor power line : M axis
23	CZ2N	Servo motor power line : N axis
24	TB2	Spindle motor power line
25		Tapped hole for grounding the flange

⚠ WARNING
 Do not touch any component in the module or any connected cable when LED 19 is on, because it is dangerous.

9.3 DETAILED DESCRIPTIONS OF CONNECTIONS

9.3.1 Common

9.3.1.1 Details of cable K1

Cable K1 is used to supply main power to the SVPM.

(1) Configuration

(a) For a power supply voltage of 200 to 240 VAC

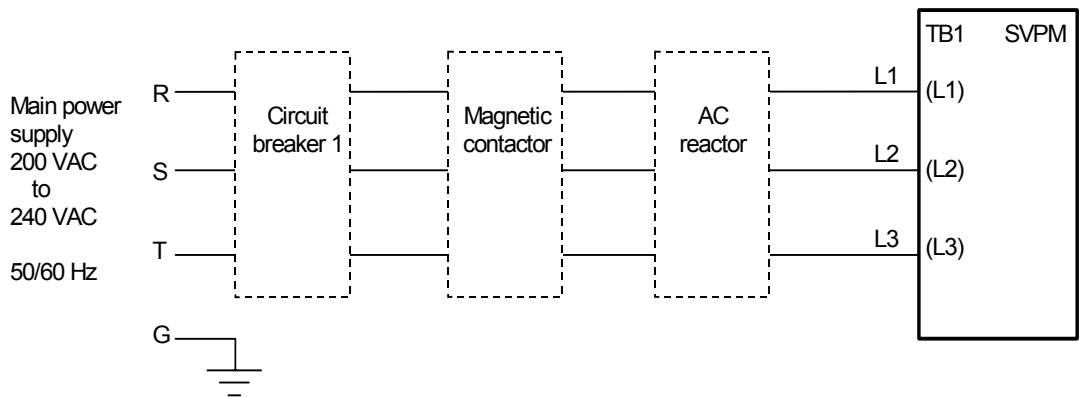

(b) For a power supply voltage of 400 to 480 VAC (an insulating transformer is needed)

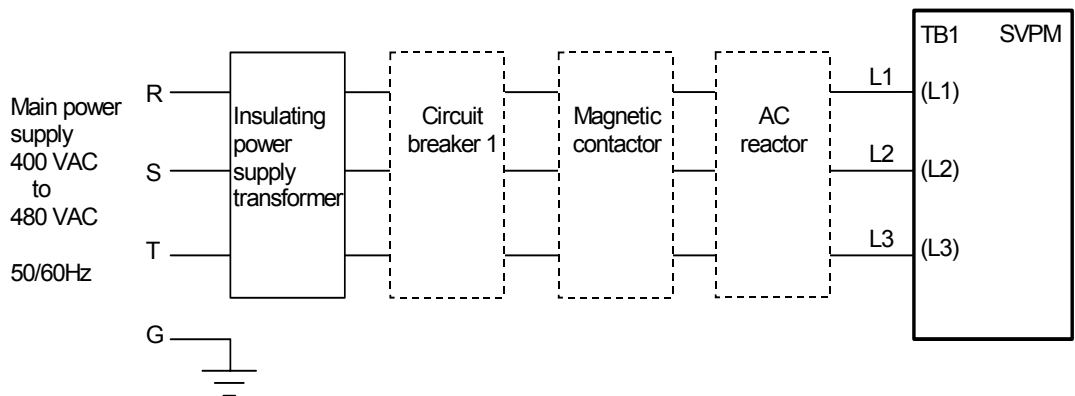

(2) Cable specifications

Model	Applicable cable		Terminal screw	Tightening torque
	Heavy-duty power cable (Note 1)	Heat-resistant cable (Note 2)		
SVPM*-5.5i	5.5 mm ² or more	5.5 mm ² or more	M5	2.0 to 2.5 N·m
SVPM*-11i	8 mm ² or more	8 mm ² or more	M5	2.0 to 2.5 N·m
SVPM*-15i	14 mm ² or more	14 mm ² or more	M5	2.0 to 2.5 N·m

NOTE

- 1 Four-conductor polyvinyl heavy-duty power cable (JIS C3312) (VCT : heat-resistant 60 °C)
- 2 Fire-retardant polyflex wire (heat-resistant 105 °C) or equivalent to LMFC manufactured by The Furukawa Electric Co., Ltd.
- 3 The cross-section area of each cable is determined under the following conditions:
 - (1) At SVPM rated output
 - (2) Environment temperature of cable : 30°C
 - (3) Number of harnesses
 - 3 (No current flows through the ground wire during normal operation.)

The required cross-section area of a cable varies depending on the environment and requirements of the user. Select an appropriate cable size.

⚠ WARNING

- 1 Defects, such as a loose screw, an incorrectly inserted connector, and a poorly crimped terminal, can lead to a motor malfunction, excessive heat generation, and a ground fault. Exercise adequate care in installing servo amplifiers.
- 2 A loose screw and a poorly crimped terminal (or, if a connector is used, a loose connector contact or an incorrect connector pin-to-cable connection) on high-current carrying power supply wires or motor power wires can lead to fire. Exercise adequate care in wiring.

9.3.1.2 Details of cable K6

Cable K6 is used to control the magnetic contactor if it is installed outside the unit.

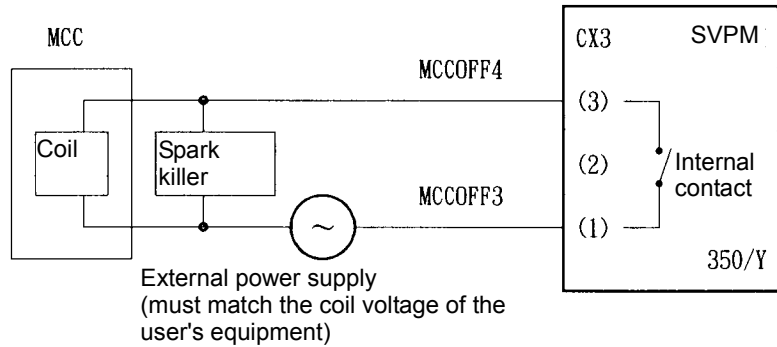

Connector	Manufactured by Tyco Electronics AMP D-3200 series Housing 2-178128-3 (1 pcs.) Contact 1-175218-2 (2 pcs.) (FANUC ordering information: A06B-6134-K201)
Cable	Two-conductor polyvinyl heavy-duty power cable (JIS C3312), conductor size of 1.25 mm ² (50/0.18), PVC sheath 9.6 mm in diameter

Internal-contact specification:

	Resistive load ($\cos\phi=1$)	Inductive load ($\cos\phi=0.4, L/R=7\text{msec}$)
Rated load	250VAC, 5A / 30VDC, 5A	250VAC, 2A / 30VDC, 2A
Maximum contact rating	5A	5A

NOTE

Always install a spark killer (CR) that matches the magnetic contactor to protect the internal contacts. The following table lists the recommended capacitances and resistances.

Coil voltage	C	R
24 VDC	0.22 μF	22 Ω
100 to 230 VAC	0.1 μF	220 Ω

9.3.1.3 Details of cable K7

Cable K7 is used to supply an emergency stop signal to the SVPM.

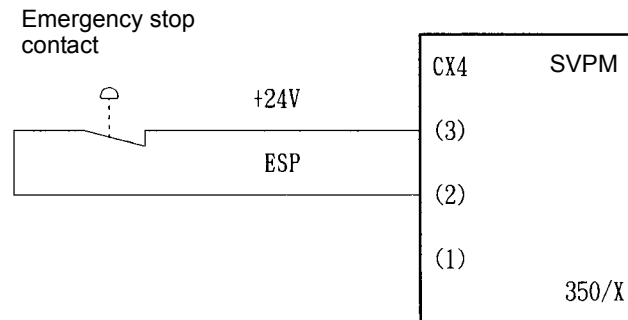

Connector	Manufactured by Tyco Electronics AMP D-3200 series Housing 1-178128-3 (1 pcs.) Contact 1-175218-2 (2 pcs.) (FANUC ordering information: A06B-6134-K201)
Cable	Two-conductor polyvinyl heavy-duty power cable (JIS C3312), conductor size of 1.25 mm ² (50/0.18), PVC sheath 9.6 mm in diameter

- (1) When the contact is ON (closed), the spindle motor and servo motor are enabled.
When the contact is OFF (open), the external magnetic contactor (MCC) is in the off state, and the spindle motor and servo motor do not operate.
- (2) When the contact is set to OFF (open) during motor rotation, the spindle motor decelerates, then stops, and the servo motor is stopped by the dynamic brake.
- (3) The contact input signal is specified as follows:
 - <1> As the external contact capacity, a voltage of at least 30 VDC and a current of at least 100 mA are required.
 - <2> Significant levels (with the voltage between input pins) when the contactless signal input mode is used:
 - Low level "logic 0": Up to 2 V
 - High level "logic 1": At least 20 V
- (4) When the SVPM main power is turned off for safety in such a case that the machine protection door is open, the contact of the ESP signal (CX4), which is input to the SVPM, must be set to OFF (open) within 200 ms after turn-off of the SVPM main power.
When the contact of the ESP signal (CX4) remains ON (closed) after the SVPM main power is turned off, a DC link low-voltage alarm occurs in the SVPM.

9.3.1.4 Details of cable K69

Cable K69 is used to supply control power (+24 V) to the SVPM.

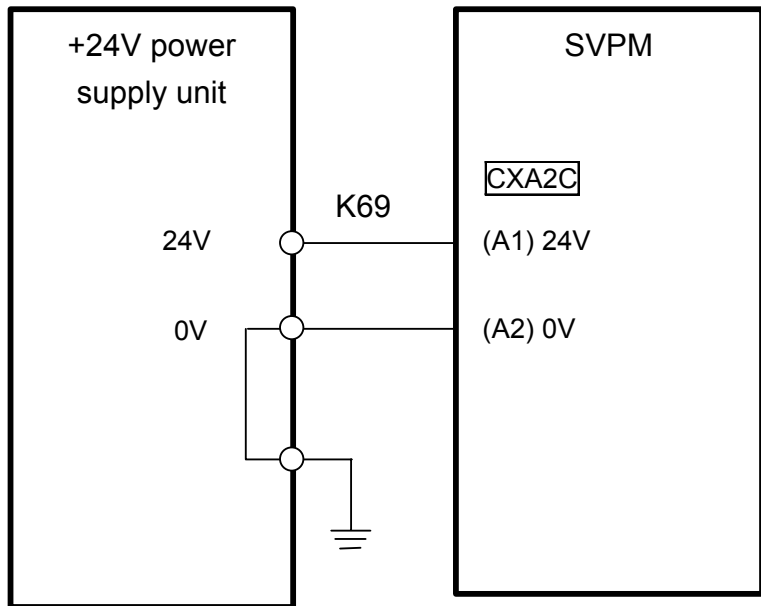

Connector	Manufactured by Tyco Electronics AMP D-2100 series Housing 1-1318119-4 (1 pcs.) Contact 1318107-1 (2 pcs.) (FANUC ordering information:A06B-6134-K201)
Cable	Conductor size : 0.5mm ² , AWG20 Instruction outer diameter : 1.11-1.87 mm

9.3.1.5 Details of cable K70

Cable K70 is used to ground the SVPM.

Grounding cable conductor diameter

Motor power cable cross-section S (mm ²)	Grounding cable cross-section (mm ²)
$S \leq 5.5$	5.5 or greater
$5.5 < S \leq 16$	S or greater
$16 < S \leq 35$	16 or greater
$35 < S$	S/2 or greater

NOTE

The following M5 crimp terminal can be used with a cable having a large conductor diameter.
Nichifu Co., Ltd. CB22-5S
Overall conductor size range : 16.78 to 22.66 mm²

(Grounding example with K70)

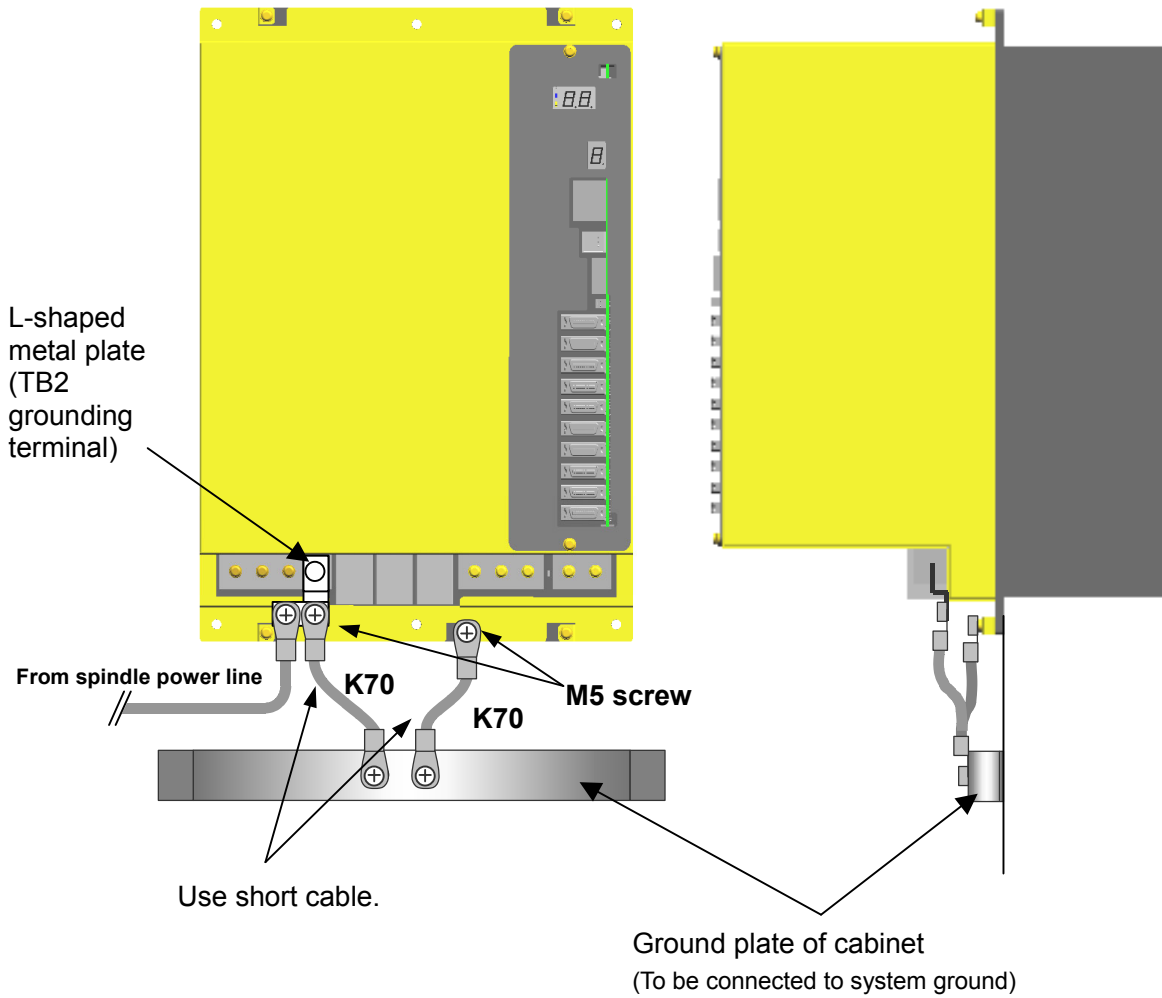

NOTE

Securing cables (crimp terminals) to the ground terminal together is not permitted. As shown in the above figure, attach one cable (crimp terminal) to each screw.

9.3.1.6 Details of cable K21

The cable K21 is a power cable used between the SVPM and motor. The cable is attached to the SVPM through the connector D-5000.

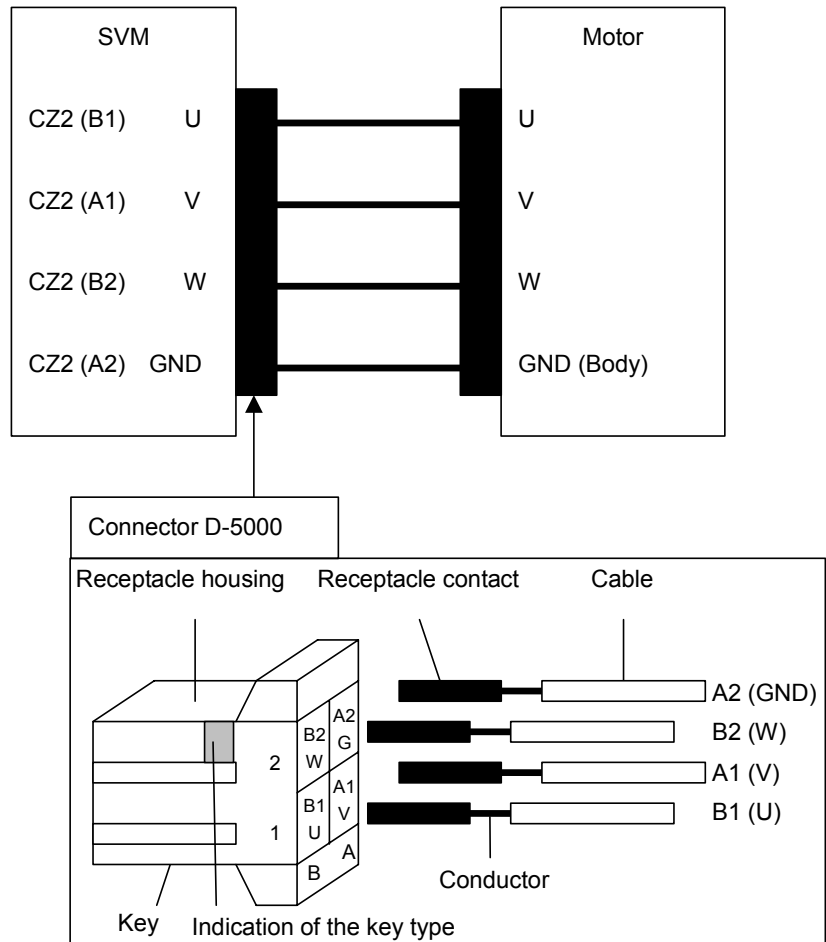

- About the receptacle housing of the SVPM-side connector
The SVPM-side connector is a key type. The key is intended to prevent incorrect connection between the axes. Select the receptacle housing that matches the SVPM and its axis that are to be used.

Specification of the key	Applicable SVPM
XX	CZ2L
XY	CZ2M
YY	CZ2N

- About the receptacle contact of the SVPM-side connector
Four types receptacle contacts are prepared for the different line diameter of the cable. Please use the receptacle contact which suits the line diameter of the cable.

- About the cable specification
Select the cable specification by considering the following conditions for use.
 - <1> Motor current rating or current needed in use on a real machine
 - <2> Cable type (heat resistance temperature, etc.)
 - <3> Environment in which the cable is installed (operating ambient temperature, etc.)
 - <4> Need of water proofing (pay attention to the diameter of the applicable cable clamp)
 - <5> Certification for CE marking (compliance with various safety standards and EMC standard)
 - <6> Securing insulation space among the cable pins at the time of cabling

- About the motor-side connector
The specification of the motor-side connector varies from one motor model to another.
Refer to "FANUC AC SERVO MOTOR β is series Descriptions (B-65302EN)" for explanations about the specification of the motor-side connector.

9.3.1.7 Details of cable K22

The cable K22 is used to connect the SVPM and Pulsecoder.

For servo motor β is series (β 2/4000is to β 22/2000is)

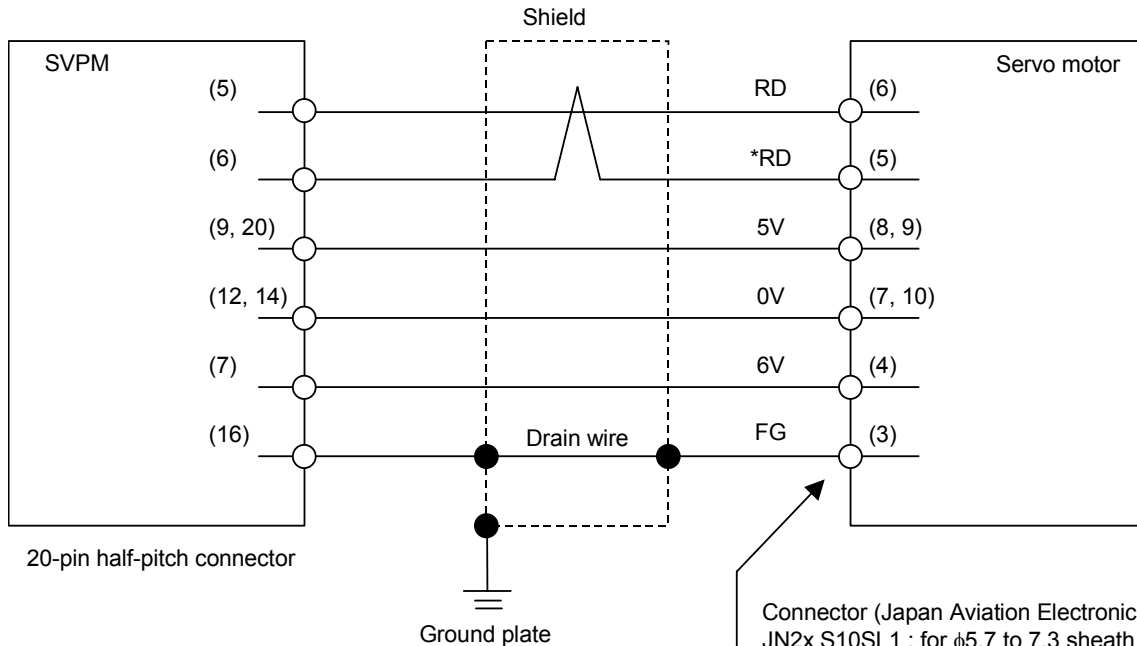

Connector (Japan Aviation Electronics Industry)
 JN2x S10SL1 : for ϕ 5.7 to 7.3 sheath diameter
 JN2x S10SL2 : for ϕ 6.5 to 8.0 sheath diameter
 D : Straight plug
 F : Angle plug
 Contact (Japan Aviation Electronics Industry)
 JN1-22-22S

Using cable conductor

Signal name	Cable length : 28m or less	Cable length : 50m or less
5V, 0V, 6V	0.3mm ² × 5 (Note 4) Wire construction 12/0.18 or 60/0.08 Insulation outer diameter ϕ 0.8 to ϕ 1.5	0.5mm ² × 5 (Note 4) Wire construction 20/0.18 or 104/0.08 Insulation outer diameter ϕ 0.8 to ϕ 1.5
RD, *RD	0.18mm ² or more Twisted-pair wire Insulation outer diameter ϕ 0.8 to ϕ 1.5	0.18mm ² or more Twisted-pair wire Insulation outer diameter ϕ 0.8 to ϕ 1.5
Drain wire	0.15mm ² or more	0.15mm ² or more

See Subsection 5.4.1 for explanations about the SVPM-side connector that matches the recommended cable.

NOTE

- 1 The ground plate to which the shield is connected must be placed as close as possible to the servo amplifier so that distance between the ground plate and the servo amplifier becomes shortest.
- 2 In case that the cable is prepared by MTB, total resistance of 5V and 0V must be less than 2Ω .
- 3 Pulsecoder side connector can accept maximum 0.5mm^2 (wire construction 20/0.18 or 104/0.08, diameter $\phi 1.5$ or less) wire and sheath diameter is $\phi 5.7$ to $\phi 8.0$. In case of using thicker wire or cable, take measures described below.

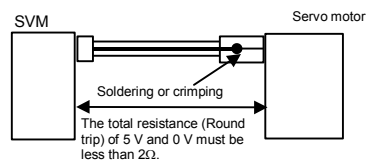
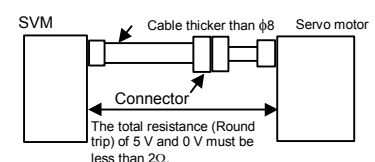
[Case 1] Cable conductor exceeds 0.5mm^2 .[Case 2] Sheath diameter of exceeds $\phi 8$.

- 4 In case of incremental Pulsecoder, 6V is not necessary to be connected.

- Crimp tool specification
A06B-6114-K201/JN1S : For 0.3mm^2
A06B-6114-K201/JN1L : For 0.18mm^2 or 0.5mm^2
- Connector kit specification
A06B-6114-K204/S : Straight plug (including a contact)
A06B-6114-K204/E : Elbow plug (including a contact)
- Recommended cable
A66L-0001-0460 : Flexible cable 28m or less long
A66L-0001-0462 : Flexible cable 50m or less long
A66L-0001-0481 : Fixed cable 28m or less long
A66L-0001-0491 : Fixed cable 50m or less long

9.3.1.8 Details of cable K27

Cable K27 is an optical fiber cable used in the FSSB interface.

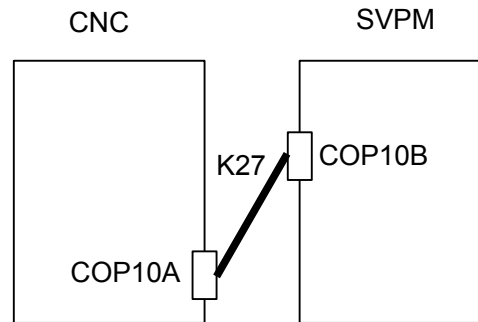

- The cable is run from connector COP10A to connector COP10B in the SVPM.
- Refer to the applicable CNC connection manual for detailed specifications of the optical fiber cable.

9.3.1.9 Details of cable K28

When a battery box is used)

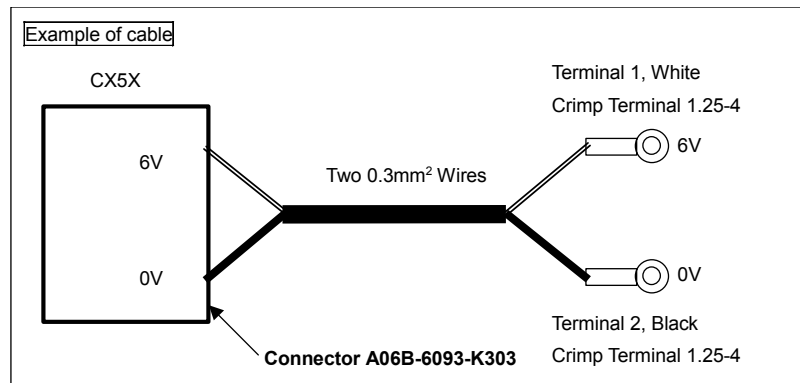
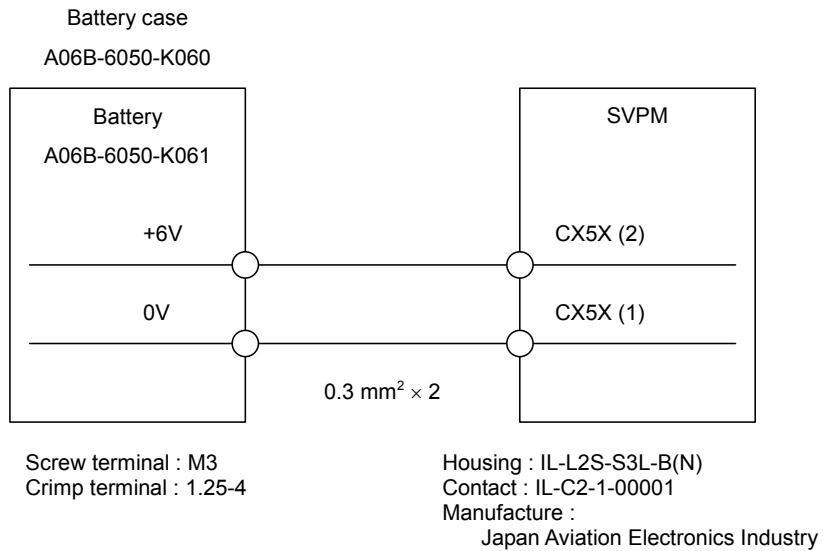

- A connector (A06B-6093-K303) is optionally available.

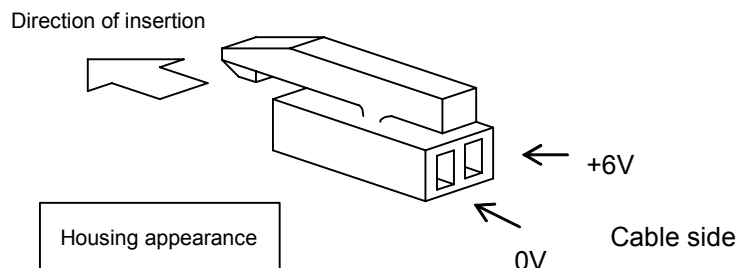

When the built-in battery is used)

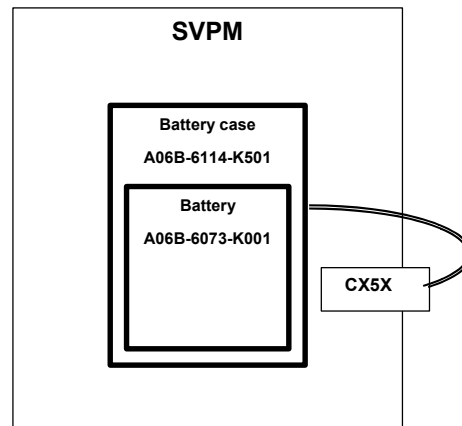

- Using the built-in battery (A06B-6073-K001) always requires the battery case (A06B-6114-K501).

9.3.2 Spindle Motor

9.3.2.1 Details of cable K10

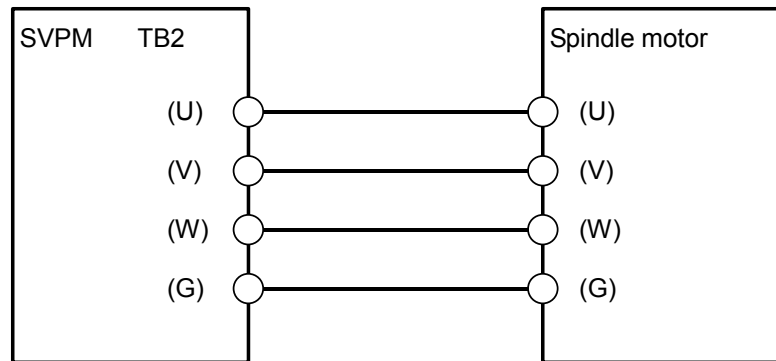

To connect the cable to the SVPM, use a crimp terminal selected according to the following table.

Amplifier model	Terminal screw	Tightening torque
SVPM2-5.5 <i>i</i> to 15 <i>i</i> SVPM3-5.5 <i>i</i> to 15 <i>i</i>	M5	2.0 to 2.5 N·m

About the cable specification

Select the cable specification by considering the following conditions for use.

- <1> Motor current rating or current needed in use on a real machine
- <2> Cable type (heat resistance temperature, etc.)
- <3> Environment in which the cable is installed (operating ambient temperature, etc.)
- <4> Need of water proofing (pay attention to the diameter of the applicable cable clamp)
- <5> Certification for CE marking (compliance with various safety standards and EMC standard)
- <6> Securing insulation space among the cable pins at the time of cabling

9.3.2.2 Details of cable K12

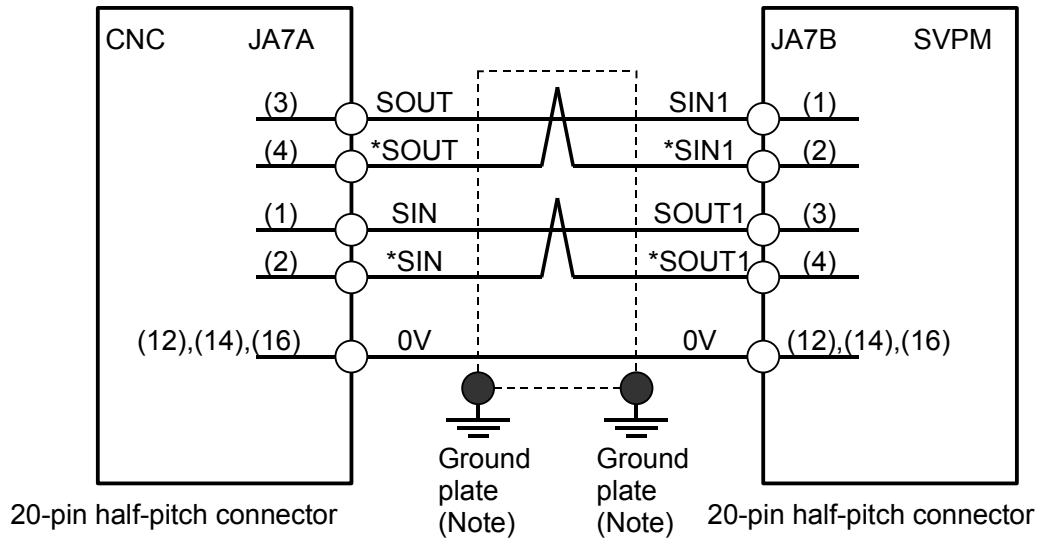

Cable specification: 0.09 mm² twisted pair with common shielded
 Recommended cable (wire only): A66L-0001-0284#10P
 See Section 5.4.1 for details of connectors applied to recommended cable.

NOTE
 If cable K12 is installed near the likes of a power cable, its shielding wire must be connected to a ground plate. If an SVPM is installed near the CNC, however, it is not necessary to connect the shielding wire to a ground plate.

Connector pin assignment

JA7A and JA7B

9	5V (Note 1)	10		19		20	5V (Note 1)
7		8		17		18	5V (Note 1)
5		6		15		16	0V
3	SOUT	4	*SOUT	13		14	0V
1	SIN	2	*SIN	11		12	0V

NOTE

- 1 The +5V pin is intended for optical link transmission based on the optical I/O link adapter. Do not use it when a metal cable is being used; otherwise, the +5V line of the CNC will be short-circuited with that of the SVPM.
- 2 SVPM serial interface connection using an optical fiber cable
The use of an optical I/O link adapter with the SVPM serial interface extends the maximum allowable length of the optical fiber cable to up to 200 m.
Use optical fiber cables in the following cases:
 - When the required cable length is 20 m or longer.
 - When the cable must be extended across multiple cabinets, and the cabinets cannot be connected with a grounding wire 5.5 mm² or larger.
 - The cable may be affected by noise, for example, if the cable is laid near a strong magnetic noise source like a welding machine or in parallel with a power line over a long distance.

9.3.2.3 Details of cable K14

(1) For the motor with *Mi* sensor

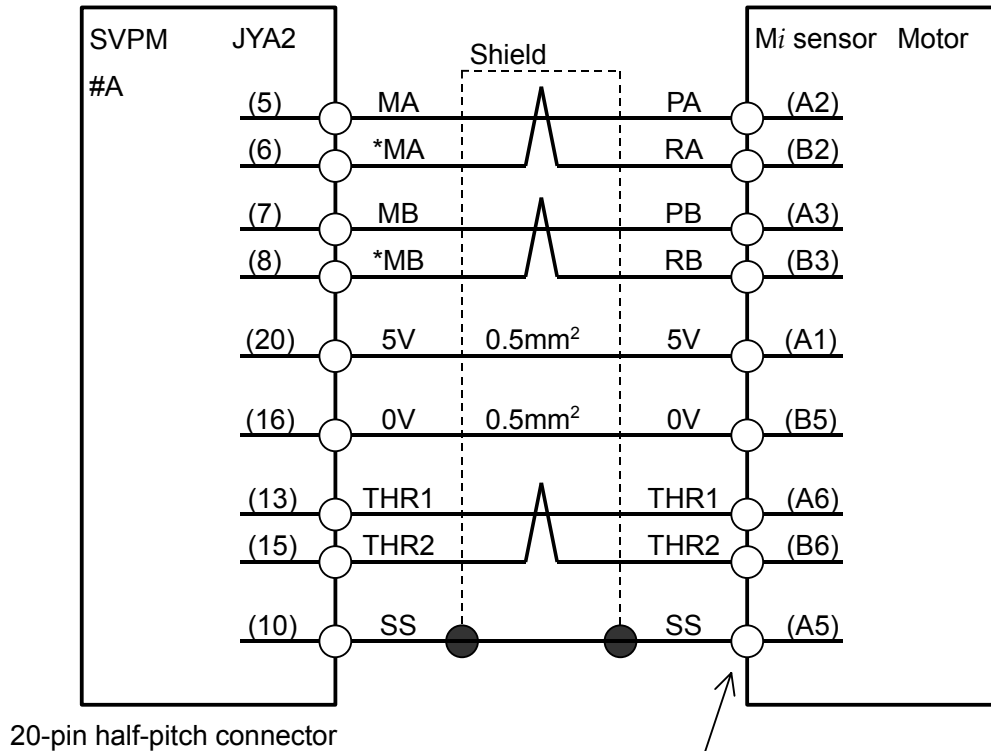

Manufactured by Tyco Electronics AMP
 Housing : 178289-6
 Contact : 1-175217-2

Cable specification : 6 common shielded cable
 (Three 0.18mm² twisted pairs + 0.5mm² wires)

Recommended cable conductor : A66L-0001-0368

See Section 5.4.1 for explanations about the JYA2-side connector that matches the recommended cable.

NOTE
 If only one 5V line and only one 0V line are used, use pins 20 and 16 for them, so that, if the connector is attached the wrong way, the sensor can be prevented from being damaged.

Connector pin assignment

JYA2

9	5V	10	SS	19	#	20	5V
7	MB	8	*MB	17	#	18	5V
5	MA	6	*MA	15	THR2	16	0V
3	#	4	#	13	THR1	14	0V
1	MZ	2	*MZ	11	#	12	0V

NOTE

Do not use any pin that is marked #, because they may already be in use for input/output signals for an optional PCB.

Pin arrangement of the connector (manufactured by Tyco Electronics AMP) on the motor side

A1	+5V	B1	
A2	PA	B2	RA
A3	PB	B3	RB
A4		B4	
A5	SS	B5	0V
A6	THR1	B6	THR2

9.3.2.4 Details of cable K16

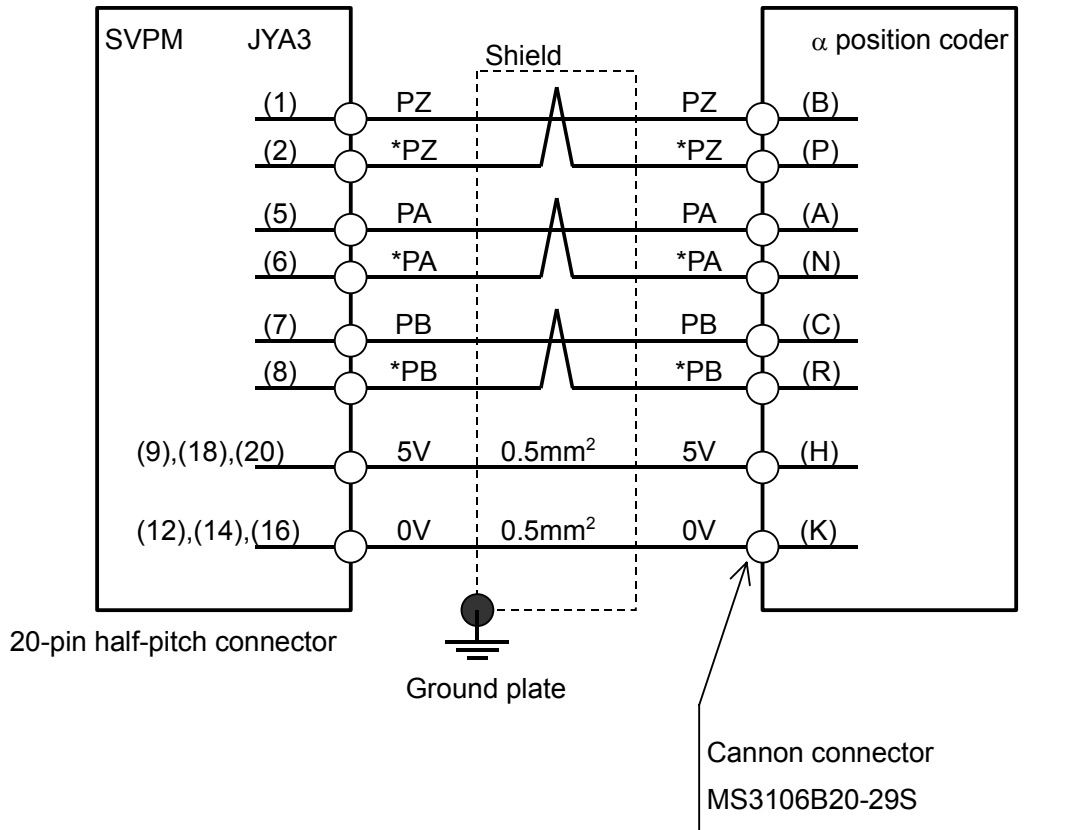

Cable specification : 6 common shielded cable

(Three 0.18mm² twisted pairs + 0.5mm² wires)

Recommended cable conductor : A66L-0001-0286

See Section 5.4.1 for explanations about the JYA3-side connector that matches the recommended cable.

NOTE

If only one 5V line and only one 0V line are used, use pins 20 and 16 for them, so that, if the connector is attached the wrong way, the sensor can be prevented from being damaged.

Connector pin assignment

JYA3

9	5V	10	#	19	#	20	5V
7	PB	8	*PB	17	#	18	5V
5	PA	6	*PA	15	EXTSC	16	0V
3	#	4	#	13	SCCOM	14	0V
1	PZ	2	*PZ	11	24V	12	0V

NOTE

Do not use any pin that is marked #.

Pin arrangement of the cannon connector on the position coder side

A	PA	B	PZ	C	PB
D		E		F	
G		H	+5V	J	
K	0V	L		M	
N	*PA	P	*PZ	R	*PB
S		T			

9.3.2.5 Details of cable K17

(1) For the motor with MZi sensor

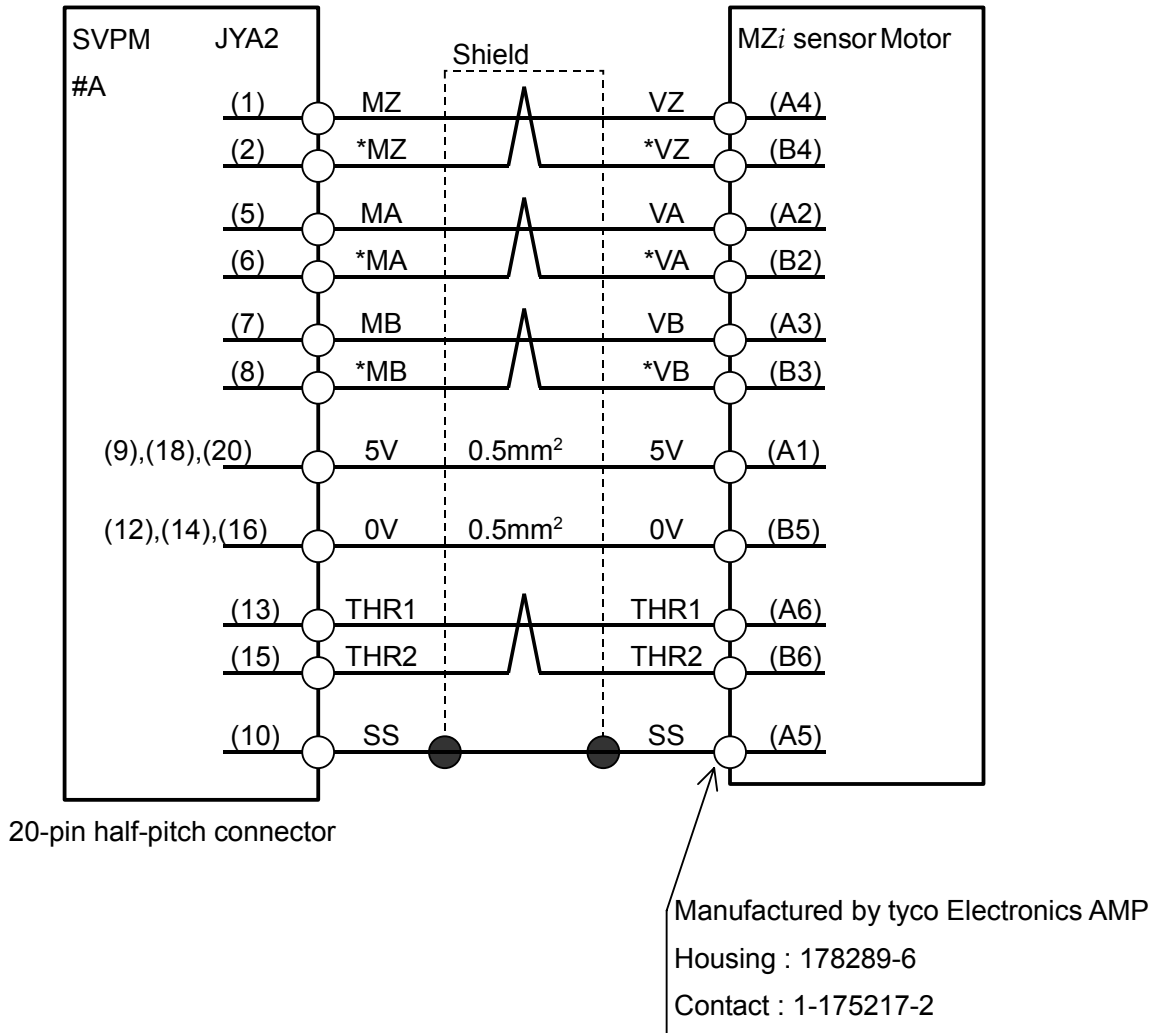

Cable specification : 6 common shielded cable
(Four 0.18mm² twisted pairs + 0.5mm² wires)
Recommended cable conductor : A66L-0001-0368
See Section 5.4.1 for explanations about the JYA2-side connector that matches the recommended cable.

NOTE
If only one 5V line and only one 0V line are used, use pins 20 and 16 for them, so that, if the connector is attached the wrong way, the sensor can be prevented from being damaged.

Connector pin assignment

JYA2

9	5V	10	SS	19	#	20	5V
7	MB	8	*MB	17	#	18	5V
5	MA	6	*MA	15	THR2	16	0V
3	#	4	#	13	THR1	14	0V
1	MZ	2	*MZ	11	#	12	0V

JYA4

9	5V	10	SS	19	#	20	5V
7	MB	8	*MB	17	#	18	5V
5	MA	6	*MA	15		16	0V
3	#	4	#	13		14	0V
1	MZ	2	*MZ	11	#	12	0V

NOTE

Do not use any pin that is marked #, because they may already be in use for input/output signals for an optional PCB.

Pin arrangement of the connector (manufactured by Tyco Electronics AMP) on the motor side

A1	+5V	B1	
A2	VA	B2	*VA
A3	VB	B3	*VB
A4	VZ	B4	*VZ
A5	SS	B5	0V
A6	THR1	B6	THR2

9.3.2.6 Details of cable K33

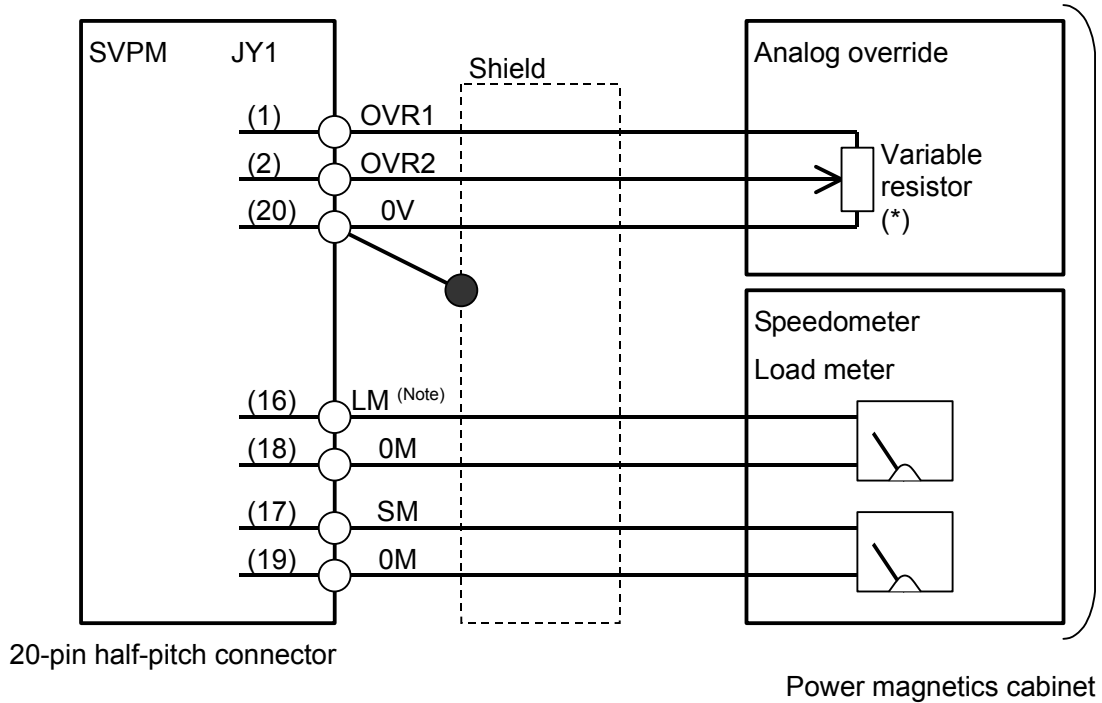

Cable specification : 0.09mm² common shielded cable
 Recommended cable conductor : A66L-0001-0284#10P
 See Section 5.4.1 for explanations about the JY1-side connector that matches the recommended cable.

- NOTE**
- 1 Select such an external resistance such that VR+R1 falls within the range between 2 kΩ and 10 kΩ .
 - 2 No LM output is included in the #C specification. For the SM output, select the load meter or speedometer by parameter setting.

Connector pin assignment

JY1

9	#	10	#	19	0M	20	0V
7	#	8	#	17	SM	18	0M
5	#	6	#	15	#	16	LM
3	#	4	#	13	#	14	#
1	OVR1	2	OVR2	11	#	12	#

NOTE

Pins indicated # are intended to input or output signals used on a spindle check board. Do not connect any other signal line to them.

Voltage signal for the speedometer (SM)

By externally connecting a tachometer, the speed of the spindle motor can be indicated. The voltage (DC) proportional to the speed (for the #C specification, an estimated speed) is output, regardless of the rotation direction of the motor. At the maximum motor speed, +10 V is output.

The output voltage of the speedometer in the forward direction and reverse direction is calibrated using a parameter. The precision is $\pm 3\%$ Max.

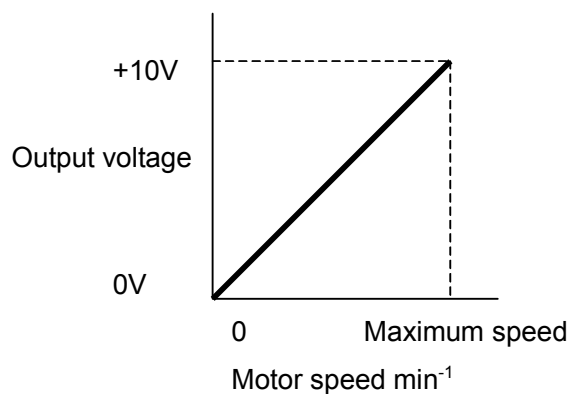

Voltage signal for the load meter (LM)

The load meter indicates the percentage of the load to the maximum motor output (load ratio). A voltage of 10 V is output at the maximum output.

- Legend

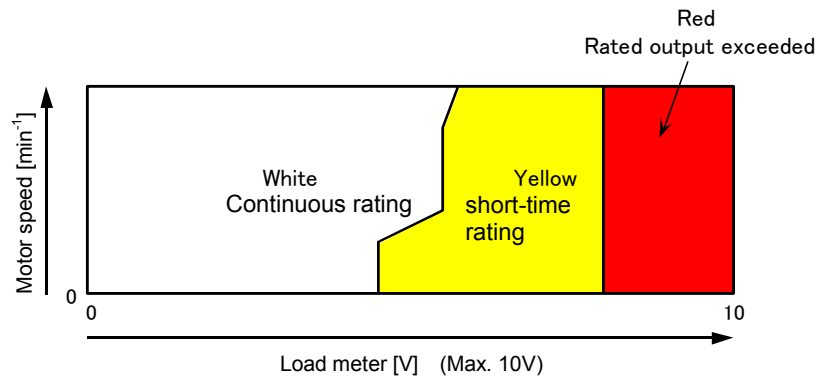

NOTE

- 1 The vertical axis represents the motor speed. If the spindle-to-motor speed ratio is not 1:1, it is recommended to convert the motor speed to the spindle speed.
- 2 The precision of load meter voltage depends on the used speed and input voltage. The maximum error is about $\pm 15\%$.

• $\beta 3/10000i$

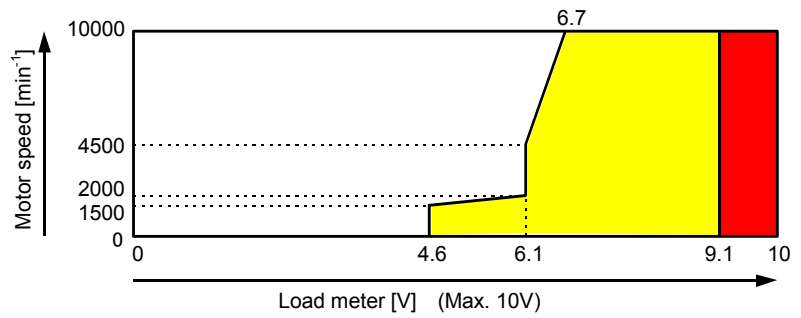

• $\beta 6/10000i$

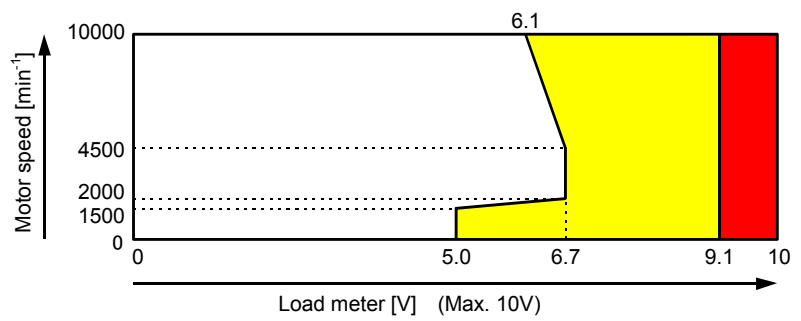

• $\beta 8/8000i$

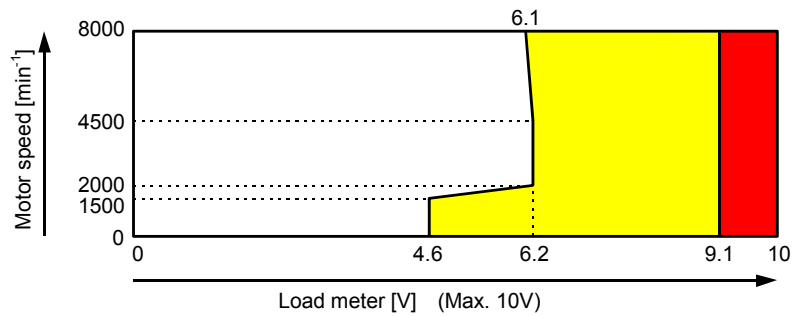

• $\beta 12/7000i$

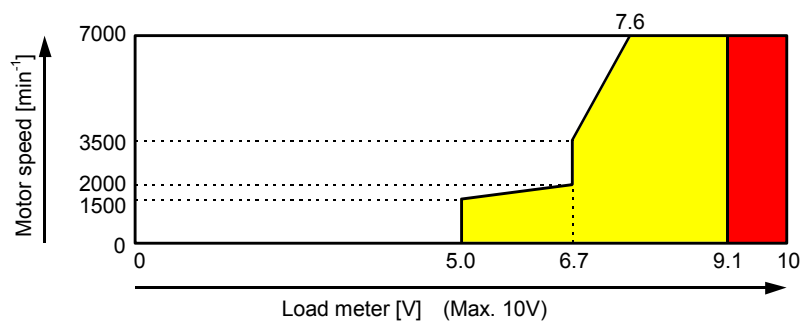

If the motor is often used at a speed of 2000 min^{-1} or higher, a simplified version of the load meter shown below could be used.

- $\beta 3/10000i$

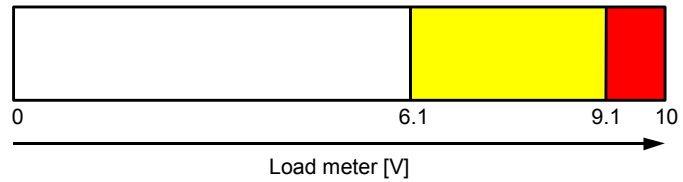

- $\beta 6/10000i, \beta 12/7000i$

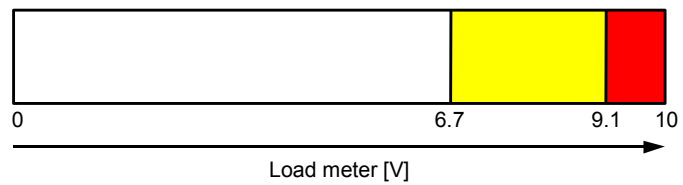

- $\beta 8/8000i$

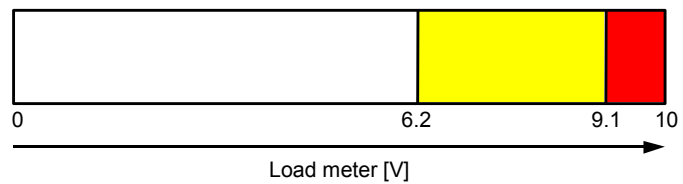

9.3.2.7 Details of cable K71

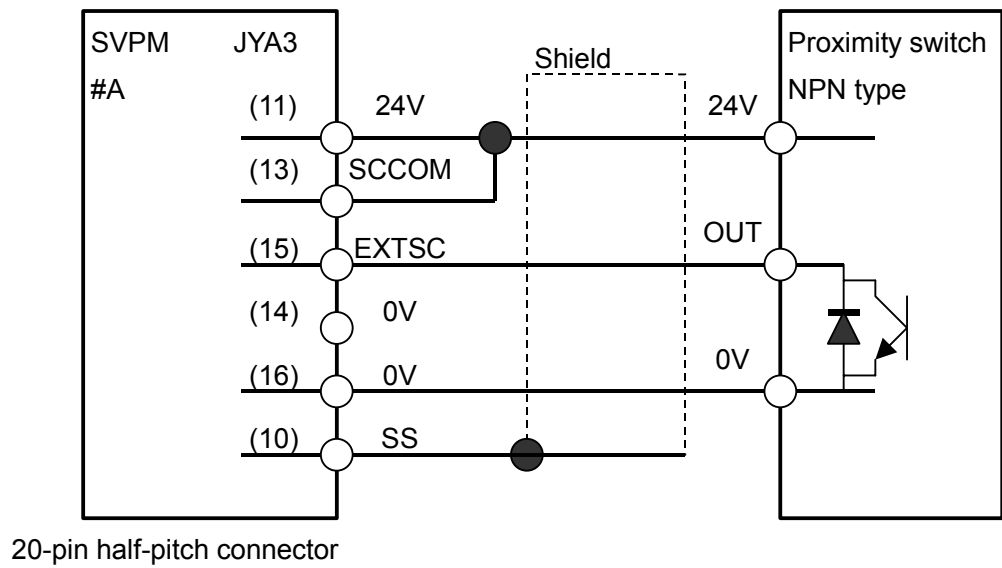
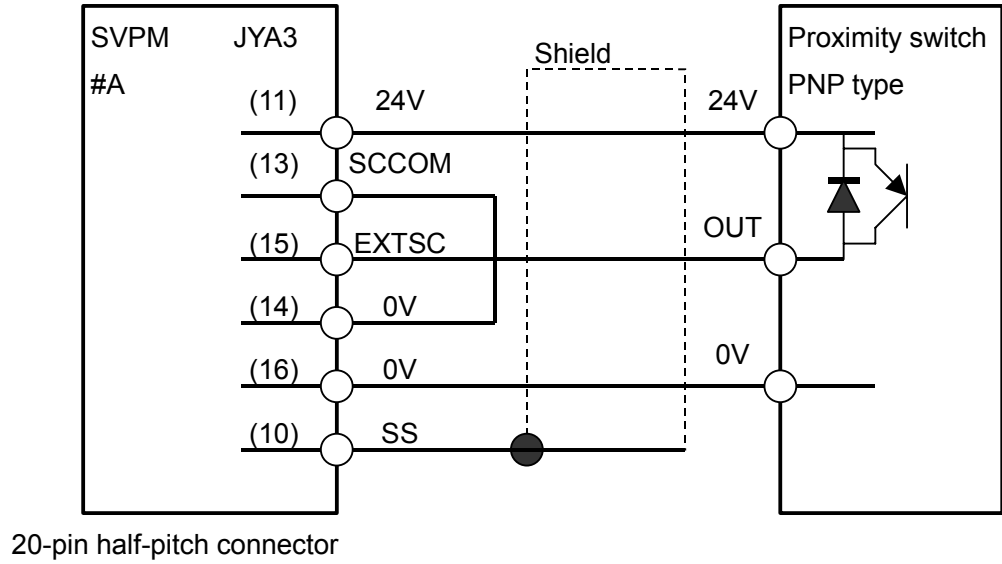

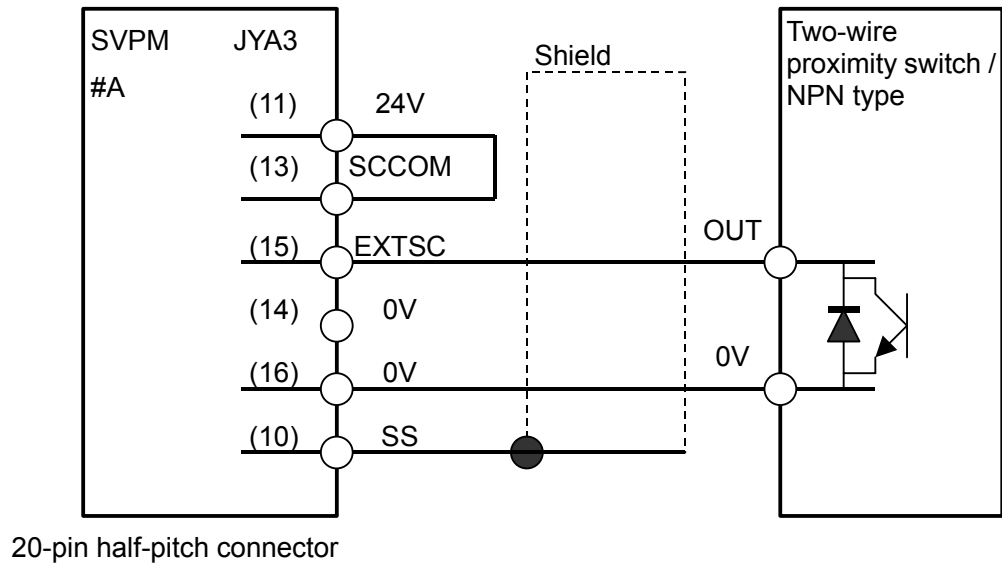

Cable specification : 0.09mm² common shielded cable
 Recommended cable conductor : A66L-0001-0284#10P
 See Section 5.4.1 for explanations about the JYA3-side connector that matches the recommended cable.

Connector pin assignment

See Subsection 5.3.3.4 “Details of cable K16.”

External one-rotation signal switch (proximity switch)

Use an external one-rotation signal switch (proximity switch) that satisfies the specifications indicated below.

(a) DC two-wire proximity switch

Item	Specification
Supply voltage	24 VDC \pm 1.5 V (24 VDC is fed from the SVPM.)
Response frequency	400 Hz or higher
Load current	16 mA or higher
Residual voltage	4 V or higher
Supply (leakage) current	1.5 mA or lower

(b) DC three-wire proximity switch

Item	Specification
Supply voltage	24 VDC \pm 1.5 V (24 VDC is fed from the SVPM.)
Response frequency	400 Hz or higher
Load current	16 mA or higher
Residual voltage	4 V or higher
Supply current	50mA or lower

NOTE

The location where a proximity switch signal occurs depends on the temperature. So, consider the ambient temperature when selecting a proximity switch.

9.3.2.8 Details of cable K79

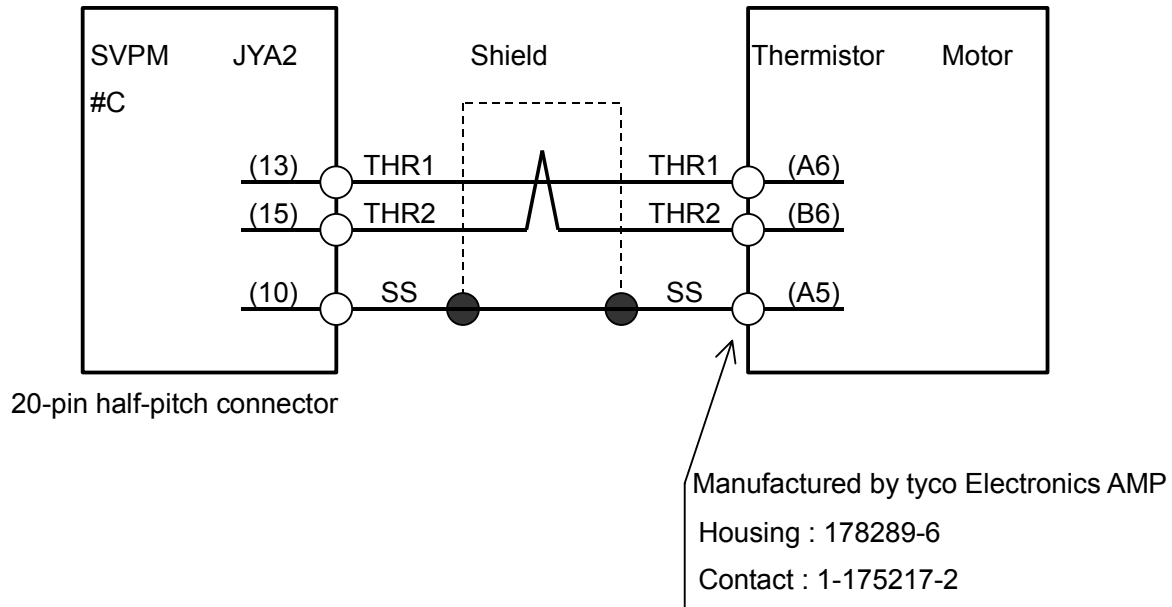

Cable specification : 0.18 mm² twisted pair with common shielded

Recommended cable conductor : A66L-0001-0368

See Section 5.4.1 for explanations about the JYA2-side connector that matches the recommended cable.

9.4 DETAILS OF CONNECTORS

9.4.1 20-Pin Half-Pitch Connectors

The following table lists the 20-pin half-pitch connectors used for the βi series servo amplifier and the recommended cables for these connectors.

Use connectors that match the recommended cables specified on the applicable connection diagram in detail.

Recommended-cable specification	Applicable connector	Connector model number	Housing model number	Connector + housing
A66L-0001-0284#10P	Crimp type	Hirose Electric Co., Ltd. FI30-20S	Sideways cable slot type FI-20-CVS2	Sideways cable slot type FI30-20S-CVS2
		Honda Tsushin Kogyo Co., Ltd. PCR-E20FA	PCR-V20LA	
	Soldering type	Hirose Electric Co., Ltd. FI40B-20S	Sideways cable slot type FI-20-CVS2	Sideways cable slot type FI40B-20S-CVS2
		Honda Tsushin Kogyo Co., Ltd. PCR-E20FS	PCR-V20LA	
A66L-0001-0286 A66L-0001-0460 A66L-0001-0462 A66L-0001-0481 A66L-0001-0491	Soldering type Note that this connector does not have pin No. 11, 13, 15, 17, or 19.	Hirose Electric Co., Ltd. FI40B-2015S	Sideways cable slot type FI-2015-CVS	Sideways cable slot type FI40B-2015S-CVS
A66L-0001-0368	Soldering type	Hirose Electric Co., Ltd. FI40B-20S	Sideways cable slot type FI-20-CVS5	Sideways cable slot type FI40B-20S-CVS5

9.4.2 Tyco Electronics AMP D-5000 Series Connector

The βi series uses the D-5000 series connector (manufactured by Tyco Electronics AMP) for the motor power cable.

The connector is provided with three keys that assure it is inserted in the correct direction. In addition, four types of receptacle contacts are available, from which the user can select the suitable one depending on the amount of current to use (size of the conductor).

Connectors and tools can be ordered directly from Tyco Electronics AMP. FANUC also furnishes options. For details, see “Order List (B-65321EN)”.

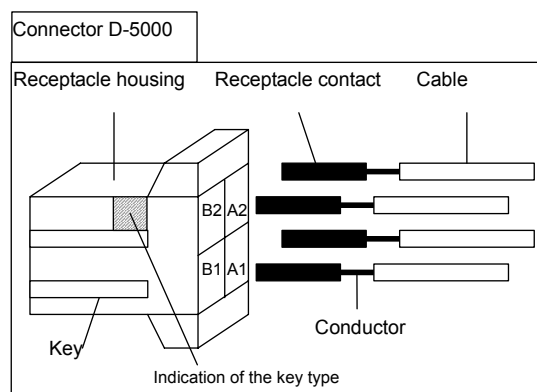

Receptacle housing

There are three different key types for the receptacle housing. Be sure to select the receptacle housing of the key type that matches the servo axis you use.

Receptacle housing model number	Specification of the key	Applicable servo amplifier
1-917807-2	XX	Servo L-axis
3-917807-2	XY	Servo M-axis
2-917807-2	YY	Servo N-axis

(Reference)

There is a cable-end connectors which are inserted no matter what key is used. Contact the connector manufacturer (Tyco Electronics AMP) for details.

Receptacle contact

Four receptacle contact types are available, so as to support different conductor diameters. Be sure to select the receptacle contact (silver plating) that matches the servo axis you use.

Rectangle contact model number		Conductor size (mm ²)	Conductor size AWG	Insulation outer diameter (mm)	Manual tool model number
SS size	1318986-6	0.50 – 1.42	20/18	1.08-3.23	1366656-1
S size	316040-6	1.23 – 2.27	16/14	3.0-3.8	234170-1
M size	316041-6	3.08 – 5.50	12/10	4.0-5.2	234171-1
L size	1318697-6	7.27 – 8.92	8	4.9-7.8	1366044-1

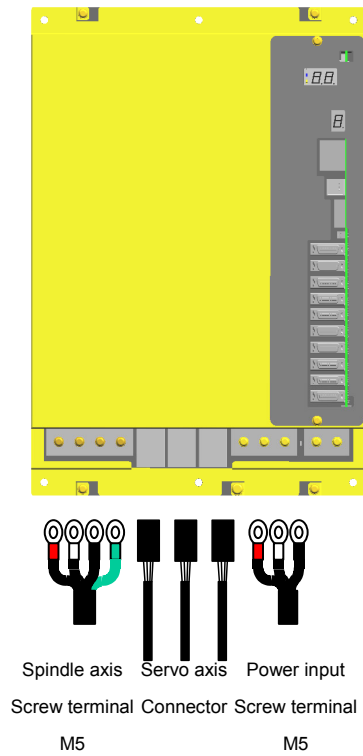

Applied	Connector key	Contact
Servo L-axis	XX 1-917807-2	SS 1318986-6
Servo M-axis	XY 3-917807-2	S 316040-6 M 316041-6
Servo N-axis	YY 2-917807-2	L 1318697-6

10 HEAT DISSIPATION

The amount of heat generated in an SVPM varies depending on its model, the current flowing through the motor, and the motor output. (Refer to the respective motor description manuals for the current and output of each motor.)

(1) Total amount of heat dissipation

The total amount of heat dissipation by the SVPM is calculated according to the following expression:

Total amount of heat dissipation

$$= a + Ka1 \times b1 + Ka2 \times b2 + Ka3 \times b3 + Ka4 \times b4 + Ka5 \times b5$$

a : Amount of heat dissipation determined by the SVPM model [W]

Ka1 to Ka5 : Coefficient determined by the SVPM

b1 : Total output of motors connected to the SVPM [kW]

b2 : Current flowing through the spindle motor [Arms]

b3 : Current flowing through the servo motor of L-axis [Arms]

b4 : Current flowing through the servo motor of M-axis [Arms]

b5 : Current flowing through the servo motor of N-axis [Arms]

SVPM (total amount of heat dissipation)

Name	Specification	a [W]	Coefficient	
SVPM2-5.5i	H201	22	Ka1	14.3
			Ka2	5.8
			Ka3	5.0
			Ka4	5.0
SVPM2-11i	H202	22	Ka1	14.3
			Ka2	5.4
			Ka3	5.0
			Ka4	5.0
SVPM2-15i	H203	22	Ka1	13.1
			Ka2	5.5
			Ka3	4.6
			Ka4	4.6
SVPM3-5.5i	H301	24	Ka1	14.3
			Ka2	5.8
			Ka3	5.0
			Ka4	5.0
			Ka5	4.6
SVPM3-11i	H302	24	Ka1	14.3
			Ka2	5.4
			Ka3	5.0
			Ka4	5.0
			Ka5	4.6

SVPM (total amount of heat dissipation)

Name	Specification	a [W]	Coefficient	
SVPM3-15 <i>i</i>	H303	24	Ka1	13.1
			Ka2	5.5
			Ka3	4.6
			Ka4	4.6
			Ka5	4.6

AC reactor

Name	Ordering number	Rated output	Total amount of heat dissipation
For SVPM2-5.5 <i>i</i> For SVPM3-5.5 <i>i</i>	A81L-0001-0155	5.5 kW	16 W
For SVPM2-11 <i>i</i> For SVPM3-11 <i>i</i>		11 kW	38 W
For SVPM2-15 <i>i</i> For SVPM3-15 <i>i</i>	A81L-0001-0156	15 kW	50 W

(2) Residual amount of heat in the cabinet

By placing the heat sink section of the SVPM outside the cabinet, the residual amount of heat in the cabinet can be calculated according to the expression below.

Residual amount of heat in the cabinet

$$= a + Ka1 \times b1 + Ka2 \times b2 + Ka3 \times b3 + Ka4 \times b4 + Ka5 \times b5$$

a : Amount of heat dissipation determined by the SVPM model [W]

Ka1 to Ka5 : Coefficient determined by the SVPM

b1 : Total output of motors connected to the SVPM [kW]

b2 : Current flowing through the spindle motor [Arms]

b3 : Current flowing through the servo motor of L-axis [Arms]

b4 : Current flowing through the servo motor of M-axis [Arms]

b5 : Current flowing through the servo motor of N-axis [Arms]

SVPM (residual amount of heat in the cabinet)

Name	Specification	a [W]	Coefficient	
SVPM2-5.5i	H201	22	Ka1	2.1
			Ka2	0.9
			Ka3	0.8
			Ka4	0.8
SVPM2-11i	H202	22	Ka1	2.1
			Ka2	0.8
			Ka3	0.8
			Ka4	0.8
SVPM2-15i	H203	22	Ka1	1.3
			Ka2	0.6
			Ka3	0.5
			Ka4	0.5
SVPM3-5.5i	H301	24	Ka1	2.1
			Ka2	0.9
			Ka3	0.8
			Ka4	0.8
			Ka5	0.7
SVPM3-11i	H302	24	Ka1	2.1
			Ka2	0.8
			Ka3	0.8
			Ka4	0.8
			Ka5	0.7
SVPM3-15i	H303	24	Ka1	1.3
			Ka2	0.6
			Ka3	0.5
			Ka4	0.5
			Ka5	0.5

11

POWER CABLE FOR SERVO MOTOR AND AMPLIFIER

11.1 SELECTING A POWER CABLE

Select the cable specification by considering the following conditions for use:

- <1> Motor current rating or current needed in use on a real machine
- <2> Cable type (heat resistance temperature, etc.)
- <3> Environment in which the cable is installed (operating ambient temperature, etc.)
- <4> Need of water proofing (pay attention to the diameter of the applicable cable clamp)
- <5> Certification for CE marking (compliance with various safety standards and EMC standard)
- <6> Insulation distance between the cable and terminal is secured at the time of wiring.

Examples of selecting a heavy-duty power cable are shown below. Fully check the cable specifications based on the actual use conditions and use an example below.

The cable diameters are determined based on JCS No. 168 D (1980), "Allowable Currents for Power Cables (1)."

Selection example of power line (reference)

[Selection example 1]

- Heavy-duty power cable specification :
Maximum allowable conductor temperature 60 °C
- Environment temperature : 30 °C

Cable diameter [mm ²]	Allowable current value [Arms]	Receptacle contact specification
0.75	Less than 11	SS size 1318986-6
1.25	Less than 15	S size 316040-6
2	Less than 19	S size 316040-6
3.5	Less than 27	M size 316041-6
5.5	Less than 35	M size 316041-6
8	Up to 43	L size 1318697-6

[Selection example 2]

- Heavy-duty power cable specification :
Maximum allowable conductor temperature 80 °C
- Environment temperature : 55 °C

Cable diameter [mm ²]	Allowable current value [Arms]	Receptacle contact specification
0.75	Less than 9.2	SS size 1318986-6
1.25	Less than 12.7	S size 316040-6
2	Less than 16.3	S size 316040-6
3.5	Less than 23.4	M size 316041-6
5.5	Less than 31.2	M size 316041-6
8	Less than 38.3	L size 1318697-6

[Selection example 3]

- Fire-retardant polyflex wire or equivalent to LMFC manufactured by The Furukawa Electric Co., Ltd.:
Maximum allowable conductor temperature 105°C
- Environment temperature : 30°C

Cable diameter [mm ²]	Allowable current value [Arms]
0.75	Less than 12
1.25	Less than 16
2	Less than 21
3.5	Less than 32
5.5	Less than 43
8	Less than 55
14	Less than 79
22	Less than 113
30	Less than 137

[Selection example 4]

- Fire-retardant polyflex wire or equivalent to LMFC manufactured by The Furukawa Electric Co., Ltd.:
Maximum allowable conductor temperature 105 °C
- Environment temperature : 55 °C

Cable diameter [mm ²]	Allowable current value [Arms]
0.75	Less than 10
1.25	Less than 13
2	Less than 17
3.5	Less than 26
5.5	Less than 35
8	Less than 44
14	Less than 64
22	Less than 92
30	Less than 112
38	Less than 131

11.2 SAMPLE POWER CABLES SELECTED FOR SERVO MOTORS (REFERENCE)

Examples of selections when a heavy-duty power cord is used

Servo motor	Continuous rated current [Arms] (reference value)	Cable diameter [mm ²] when environment temperature 30°C	Cable diameter [mm ²] when environment temperature 55°C
β2/4000is	3.3	0.75	0.75
β4/4000is	4.7	0.75	0.75
β8/3000is	6.0	0.75	0.75
β12/3000is	10.2	0.75	1.25
β22/2000is	11.3	0.75	1.25

11.3 SAMPLE POWER CABLES SELECTED FOR SPINDLE MOTORS (REFERENCE)

Environment temperature : 30°C

SVPM model	Motor model	Applicable cable		Terminal size	
		Heat-resistant 60°C (Note 1)	Heat-resistant 105°C (Note 2)	Amplifier side	Motor side
SVPM-5.5i	β3i	5.5 mm ²	3.5 mm ²	M5	M5
SVPM-11i	β6i	8 mm ²	5.5 mm ²	M5	M5
	β8i	14 mm ²	5.5 mm ²	M5	M5
SVPM-15i	β12i	14 mm ²	8 mm ²	M5	M5

Environment temperature : 55°C

SVPM model	Motor model	Applicable cable		Terminal size	
		Heat-resistant 80°C (Note 1)	Heat-resistant 105°C (Note 2)	Amplifier side	Motor side
SVPM-5.5i	β3i	5.5 mm ²	3.5 mm ²	M5	M5
SVPM-11i	β6i	8 mm ²	5.5 mm ²	M5	M5
	β8i	14 mm ²	8 mm ²	M5	M5
SVPM-15i	β12i	14 mm ²	8 mm ²	M5	M5

NOTE

- 1 Equivalent to four-conductor polyvinyl heavy-duty power cable (JIS C3312)
- 2 Fire-retardant polyflex wire or equivalent to LMFC manufactured by The Furukawa Electric Co., Ltd.

III. I/O Link

1

OVERVIEW

The FANUC SERVO AMPLIFIER βi series I/O Link option (called the βi SVM hereinafter) has the following features:

- (1) One-axis AC servo amplifier with excellent cost performance, suitable for a positioning axis
- (2) Designed for driving the βis , αis , and αi servo motors.
- (3) A position control function is provided. In addition, a set for easily controlling peripheral equipment such as a turret and ATC is provided.
- (4) The βi SVM can be connected to the Series $0i/0i$ Mate, Series $16i/18i/21i$, Series $30i/31i/32i$, and Power Mate i -MODEL D/H via the FANUC I/O Link (called the I/O Link hereinafter), therefore, easily expanding positioning axes.
- (5) Parameters, current positions, and diagnostic information can be displayed and set from a CNC.
- (6) Instructions for making a movement in synchronization with pulse trains externally input are provided, which can find various uses.
- (7) The βi SVM is designed in compliance with the following safety standards:
 - EN50178
 - UL508C
 - CSA C22.2
 - EN61000-6-2
 - EN55011

The following improvements have been made from FANUC SERVO AMPLIFIER β series I/O Link option:

- (1) HRV2 is employed as the current control method. This improves the response characteristics of the motor and makes feed operations more smoothly.
- (2) Improved maintainability
 - The new structure used allows you to remove the control PC board from the front of the βi SVM without removing the case. So, you can replace fuses more easily than before.
 - You can replace the cooling fan without removing the case.
 - Use of the Power Mate CNC manager enables the CNC to identify the βi SVM specifications and other information without opening the power magnetics cabinet. To use this function, the Power Mate CNC manager supporting this function is required.

2 CONFIGURATION

2.1 SVM1-4i AND SVM1-20i

This section shows an example of a 2-axis system configuration using two SVM units which are the SVM1-4i or SVM1-20i.

In this example, a separated regenerative discharge unit is connected but no external pulse generator is connected to the SVM unit for the first axis (the unit nearer the CNC), while no separated regenerative discharge unit is connected but an external pulse generator is connected to the SVM unit for the second axis.

The servo check board adapter and servo check board in the configuration example are provided for the first axis.

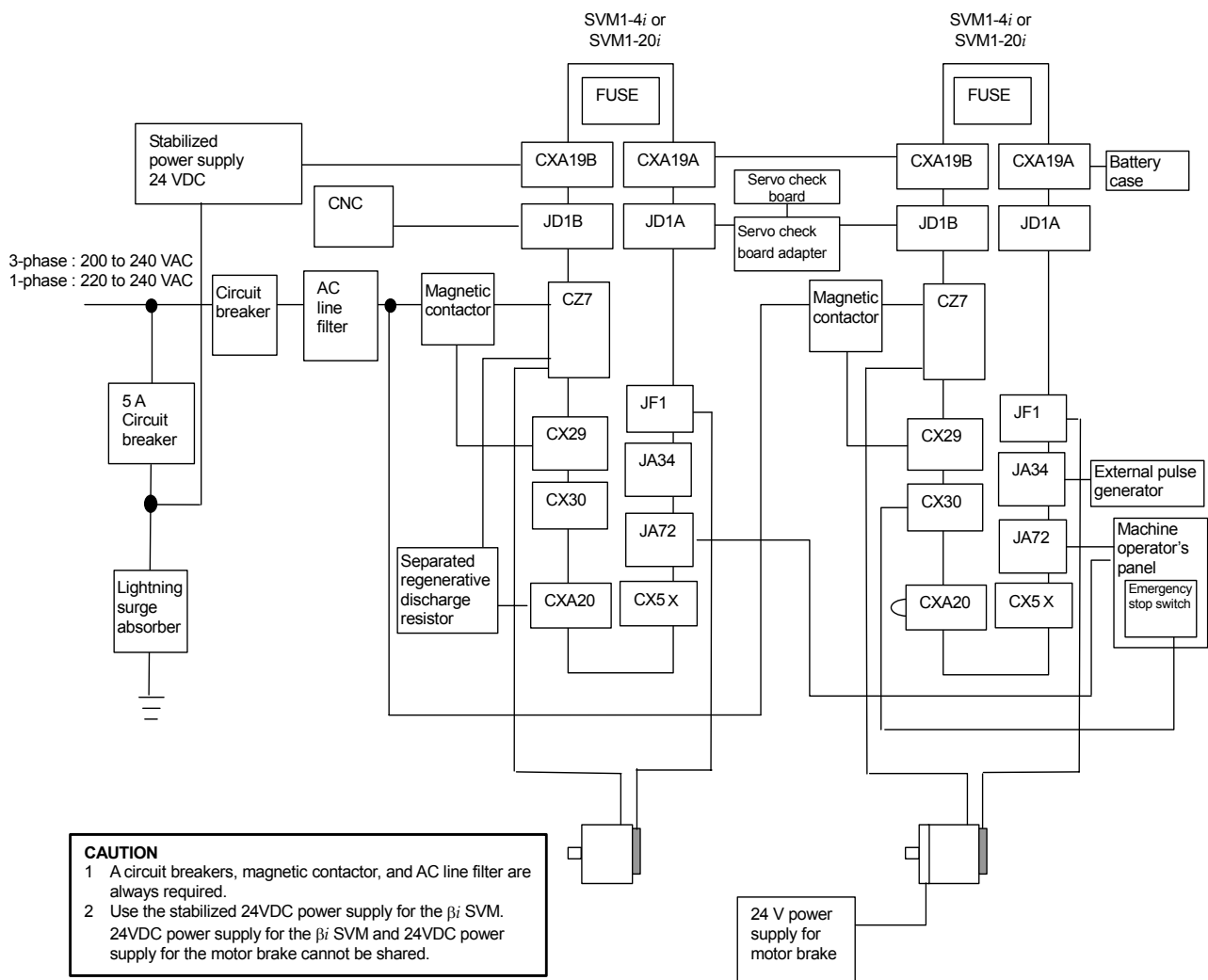

2.2 SVM1-40i AND SVM1-80i

This section shows an example of a 2-axis system configuration using the SVM1-80i for the first axis (the unit nearer the CNC) and the SVM1-40i for the second axis.

In this example, a separated regenerative discharge unit is connected but no external pulse generator is connected for the first axis, while no separated regenerative discharge unit is connected but an external pulse generator is attached for the second axis.

The servo check board adapter and servo check board in the configuration example are provided for the first axis.

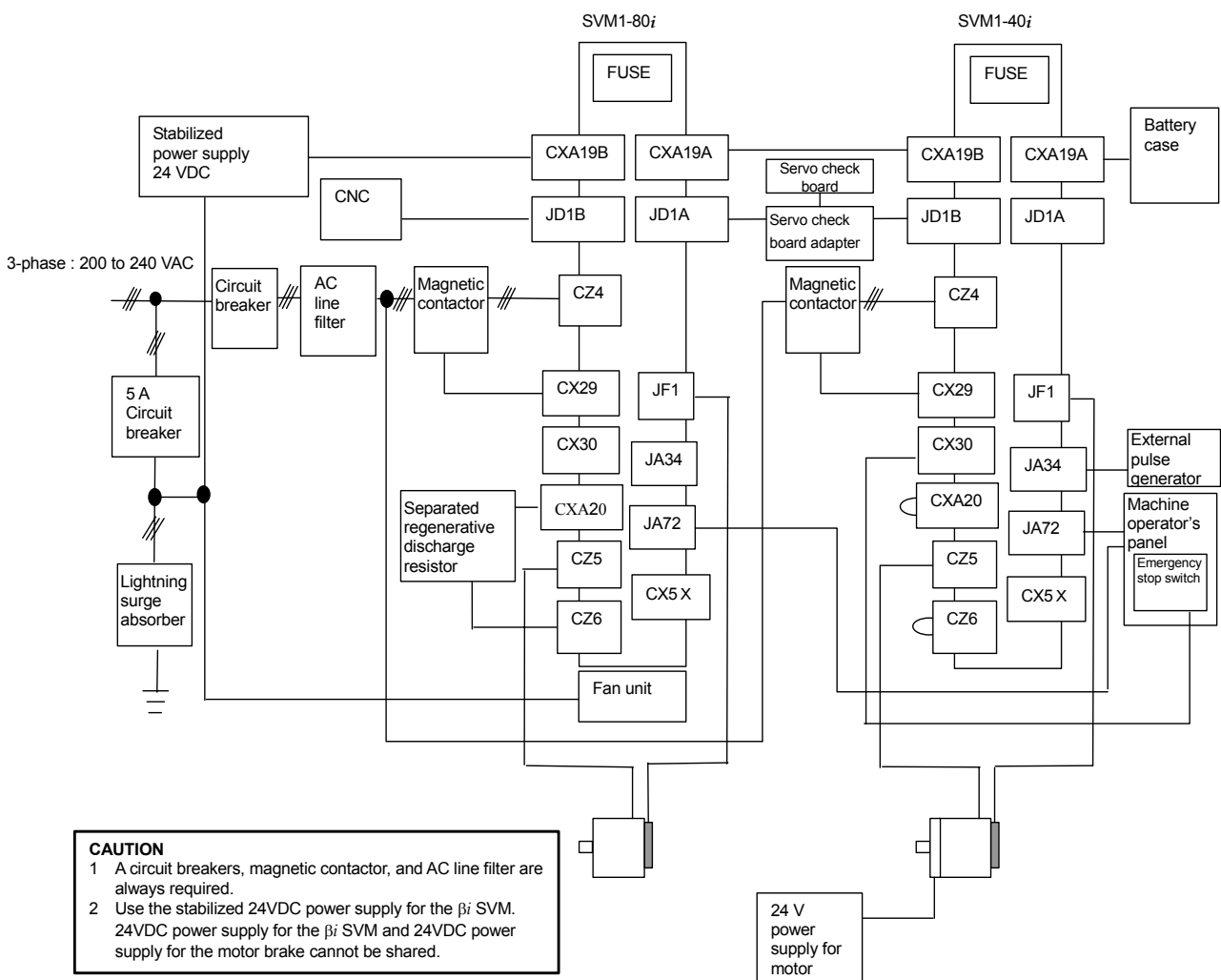

3

SPECIFICATIONS

3.1 SPECIFICATIONS

Item		SVM1-4i	SVM1-20i	SVM1-40i	SVM1-80i
No. of controlled axes		1 axis			
Interface with CNC		FANUC I/O Link			
Unit drawing No.		A06B-6132-H001	A06B-6132-H002	A06B-6132-H003	A06B-6132-H004
Power PCB drawing No.		See Section 3.1 "SPECIFICATIONS" in Part I.			
Control PCB drawing No.		A20B-8101-0200			
Main power supply	Three-phase	Input voltage			
		Input current (50Hz)			
		Power supply rating			
	Single-phase	Input voltage			
		Input current (50Hz)			
		Power supply rating			
Control power supply	Input voltage				
	Input current				
Rated output current					
Maximum output current					
Servo HRV control		HRV2			
Control method					
Dynamic brake circuit		See Section 3.1 "SPECIFICATIONS" in Part I.			
Output frequency range					
External pulse input		Differential phase A/B, 1 ch			
Internal DI		5 points (ESP, interlock, + overtravel, - overtravel, skip)			
Setting display		Performed by master CNC via I/O Link			
LEDs for status display		8 LEDs			
Protection function		<ul style="list-style-type: none"> -High Current -IPM Abnormal -High/Low Voltage of DC link -Overheat of Discharge Resistor -Low Voltage of Control Power Supply -I/O Link Communication Error -Locked Fan Motor -Disconnection of External Pulse Input -Program or Setting Error -Servo Motor Overheat -Exceeding Stroke Limit 			
Ambient temperature range		See Section 3.1 "SPECIFICATIONS" in Part I.			
Weight		1.3kg		See Section 3.1 "SPECIFICATIONS" in Part I.	
Remarks		See Section 3.1 "SPECIFICATIONS" in Part I.			

3.2 APPLICABLE MOTORS

See Section 3.2 “APPLICABLE MOTORS” in Part I.

3.3 SELECTING CIRCUIT BREAKER, MAGNETIC CONTACTOR, AND AC LINE FILTER

3.3.1 Selecting Circuit Breaker

See Subsection 3.3.1, “Selecting Circuit Breaker” in Part I.

3.3.2 Selecting Magnetic Contactor

See Subsection 3.3.2, “Selecting Magnetic Contactor” in Part I. It is recommended that one magnetic contactor be connected per βi SVM unit.

3.3.3 Selecting AC Line Filter

See Subsection 3.3.3, “AC Line Filter” in Part I.

3.4 COOLING FAN MOTORS

3.4.1 Installing the Cooling Fan Motor in the SVM1-4*i* and SVM1-20*i*

The SVM1-4*i* and SVM1-20*i* are supplied with a fan motor as standard.

Install the fan motor in the order (1), (2), and (3) as illustrated below. For an assembled diagram after the installation, see Subsection 8.1.1, "SVM1-4*i* and SVM1-20*i*".

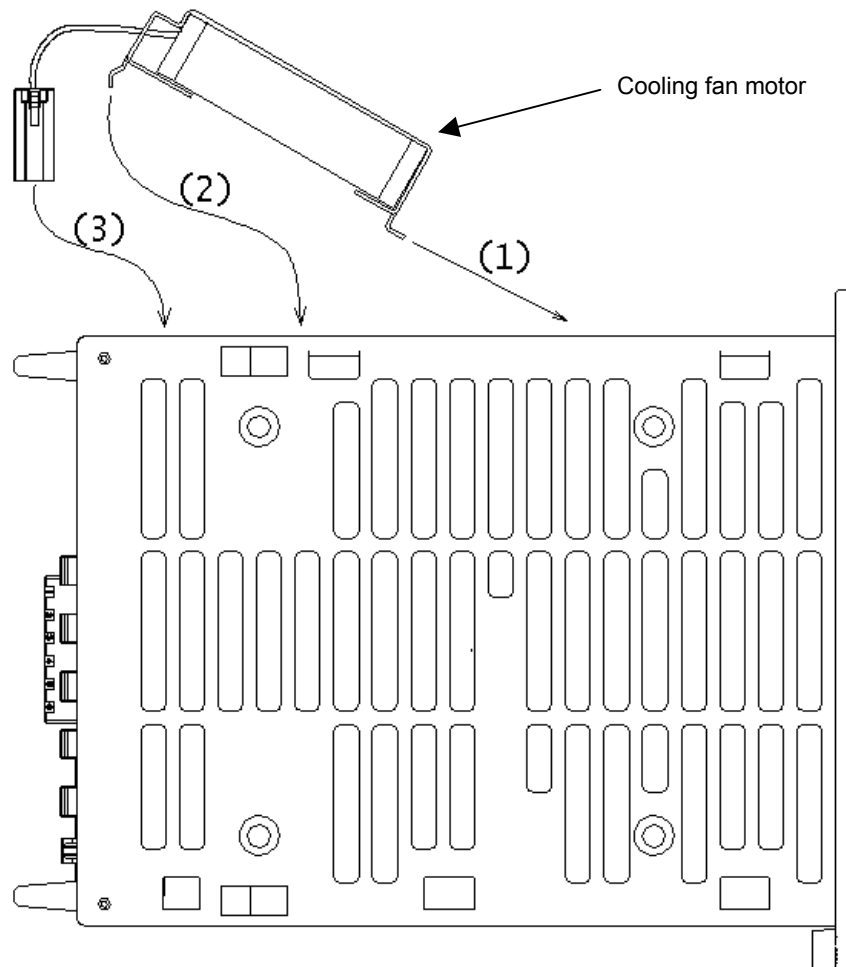

3.4.2 SVM1-80*i*

For the SVM1-80*i*, the following cooling fan motor is required:

Ordering specification
A06B-6134-K002

3.5 DERATING

Consider derating as shown below, according to ambient temperatures.

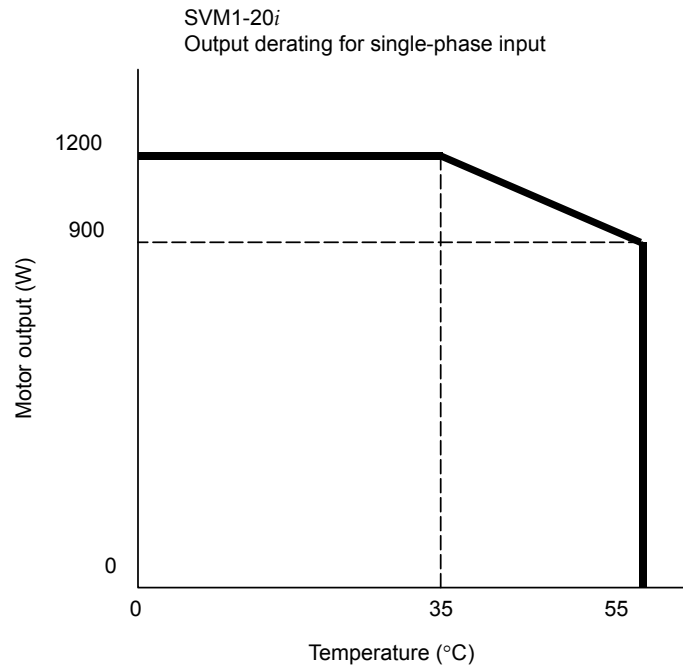

The SVM1-40i and SVM1-80i require current derating according to the ambient temperature. For details, see the current derating diagrams for the SVM1-40i and SVM1-80i in Section 3.5, "DERATING" in Part I.

3.6 SEPARATED REGENERATIVE DISCHARGE RESISTOR

See Section 3.6 "SEPARATED REGENERATIVE DISCHARGE RESISTOR" in Part I. In the description of Section 3.6, replace Table 2.7.3 (a), "Regenerative discharge capacity of the regenerative discharge resistor incorporated in servo amplifiers" with the following:

Table 3.6.3(a) Regenerative discharge capacity of the regenerative discharge unit incorporated in the βi SVM

βi SVM	Permissible regenerative energy amount
A 06B-6132-H003	50W
A 06B-6132-H004	130W

4

ORDERING INFORMATION

See Chapter 4 “ORDERING INFORMATION” in Part I.

5

POWER SUPPLY

5.1 INPUT POWER SUPPLY

5.1.1 Three-phase Input Power Supply for Motor Power

See Subsection 5.1.1 “Three-phase Input Power Supply for Motor Power” in Part I.

5.1.2 Single-phase Input Power Supply for Motor Power

See Subsection 5.1.2 “Single-phase Input Power Supply for Motor Power” in Part I.

5.1.3 Control Power

Be sure to use a stabilized power supply as the 24-V power supply for the βi SVM. The 24-V power supply for motor brakes cannot be shared.

- Nominal rated voltage: 24VDC
- Allowable voltage fluctuation:
±10% (including momentary variations and ripples)
- Power supply rating: 0.9 A (per βi SVM unit)

5.1.3.1 Sequence for turning on control power supply

Turn on the control power supply of the βi SVM at the same time when the power to the host controller connected via the I/O Link is turned on or before the host controller is turned on. When turning off the power to the host controller, be sure to also turn off the control power supply of the βi SVM.

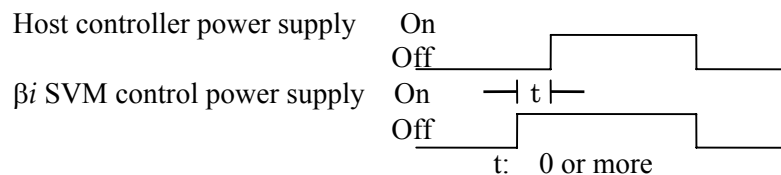

5.2 POWER TRANSFORMER FOR EXPORTS

See Section 5.2 “POWER TRANSFORMER FOR EXPORTS” in Part I.

6

INSTALLATION CONDITIONS AND NOTES

See Chapter 6 "INSTALLATION CONDITIONS AND NOTES" in Part I.

In the four figures shown in Section 6.4, "INSTALLING LIGHTNING SURGE ABSORBERS", change the positions of the magnetic contactor and AC line filter.

7

GROUNDING

7.1 SVM1-4i AND SVM1-20i

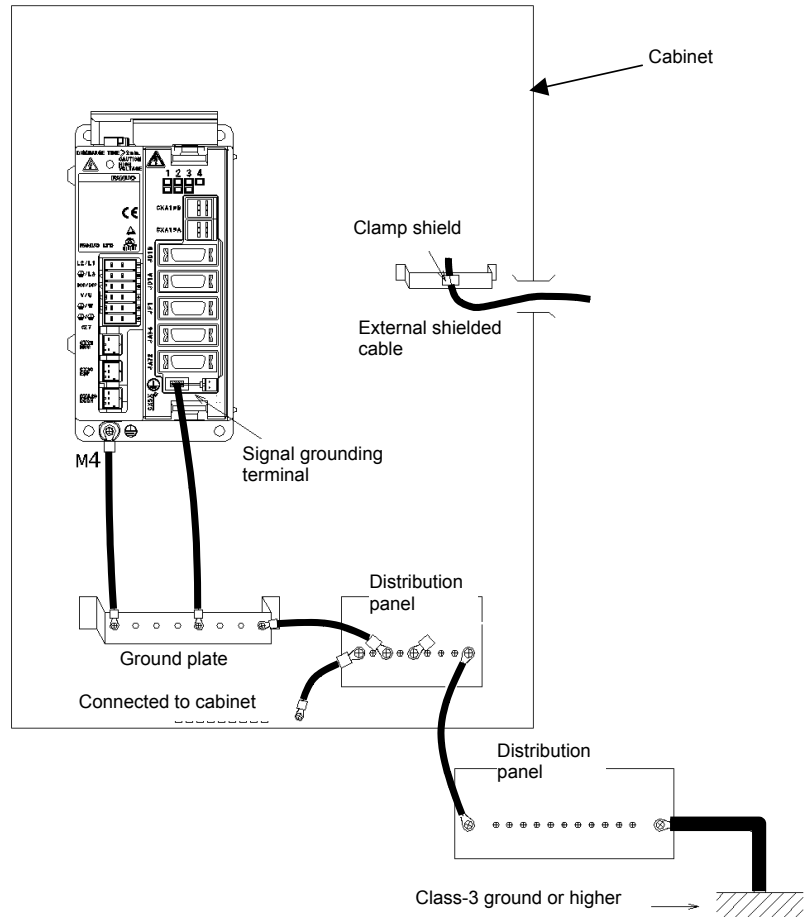

⚠ CAUTION

- 1 Ground the shield of the cable drawn from the outside of the cabinet to the ground plate provided near the cabinet inlet with a clamp. This is to prevent noise on the cable shield outside the cabinet from getting into the cabinet and also to prevent noise inside the cabinet from radiating outside.
- 2 Connect the FG terminal of the β_i SVM to a ground. Use a Faston terminal (A65L-0001-0148/2) as the terminal on the β_i SVM side. Use a 2-mm² or thicker twisted cable with a length of around 100 to 300 mm for installation. If the FG terminal is not grounded as mentioned here, the unit becomes more susceptible to noise.
- 3 The flange of the β_i SVM has an M4 threaded hole for grounding. Use this hole for grounding as shown in the above figure.

7.2 SVM1-40i and SVM1-80i

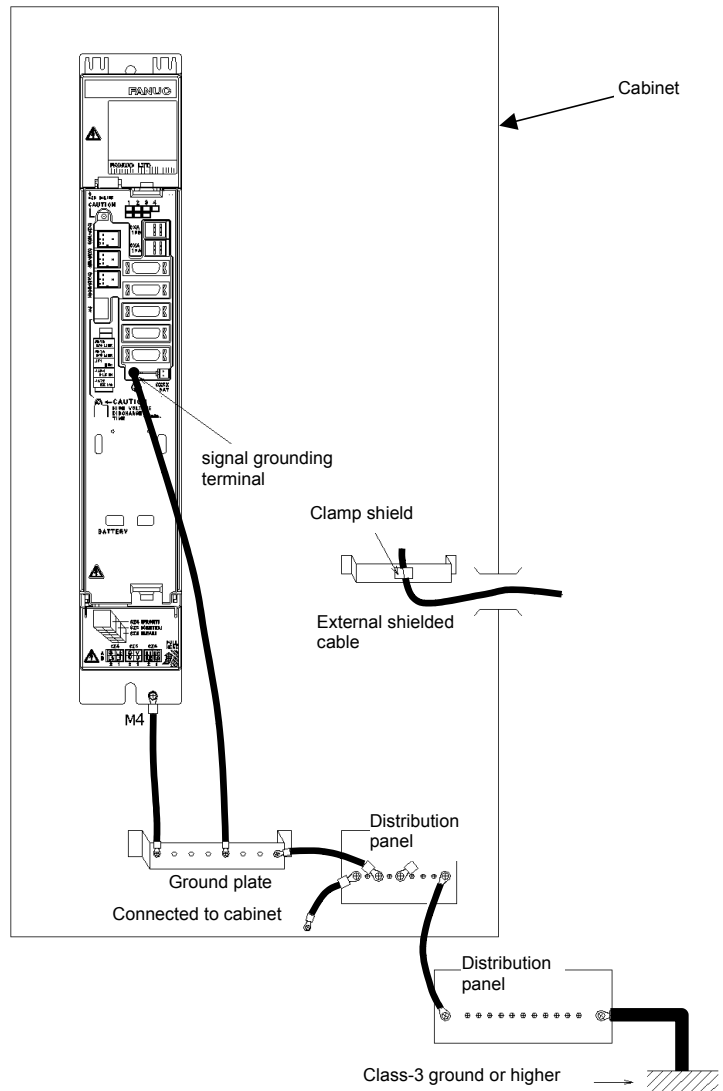

⚠ CAUTION

- 1 Ground the shield of the cable drawn from the outside of the cabinet to the ground plate provided near the cabinet inlet with a clamp. This is to prevent noise on the cable shield outside the cabinet from getting into the cabinet and also to prevent noise inside the cabinet from radiating outside.
- 2 Connect the signal grounding terminal of the βi SVM to a ground. Use a Faston terminal (A65L-0001-0148/2) as the terminal on the βi SVM side. Use a 2-mm² or thicker twisted cable with a length of around 100 to 300 mm for installation. If the signal grounding terminal is not grounded as mentioned here, the unit becomes more susceptible to noise.
- 3 The flange of the βi SVM has an M4 threaded hole for grounding. Use this hole for grounding as shown in the above figure.

8

EXTERNAL DIMENSIONS / PANEL CUT-OUT DRAWINGS / MAINTENANCE AREA

8.1 EXTERNAL DIMENSIONS

8.1.1 SVM1-4i and SVM1-20i

β i SVM with the separated regenerative discharge unit and the battery (dedicated lithium battery) not installed

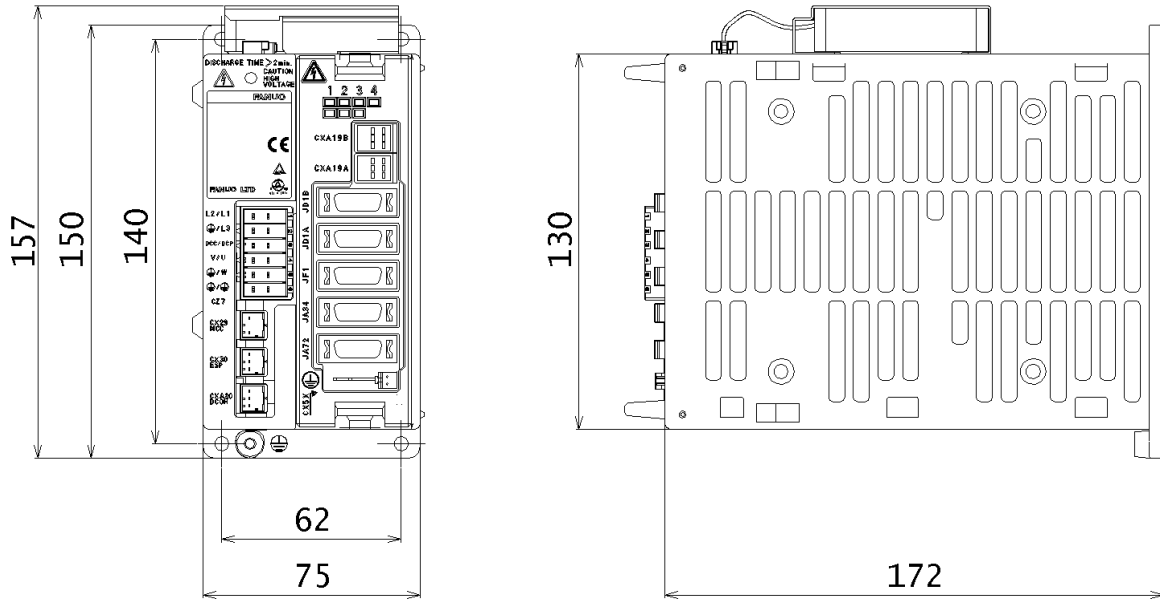

β i SVM with the separated regenerative discharge unit and the battery (dedicated lithium battery) installed

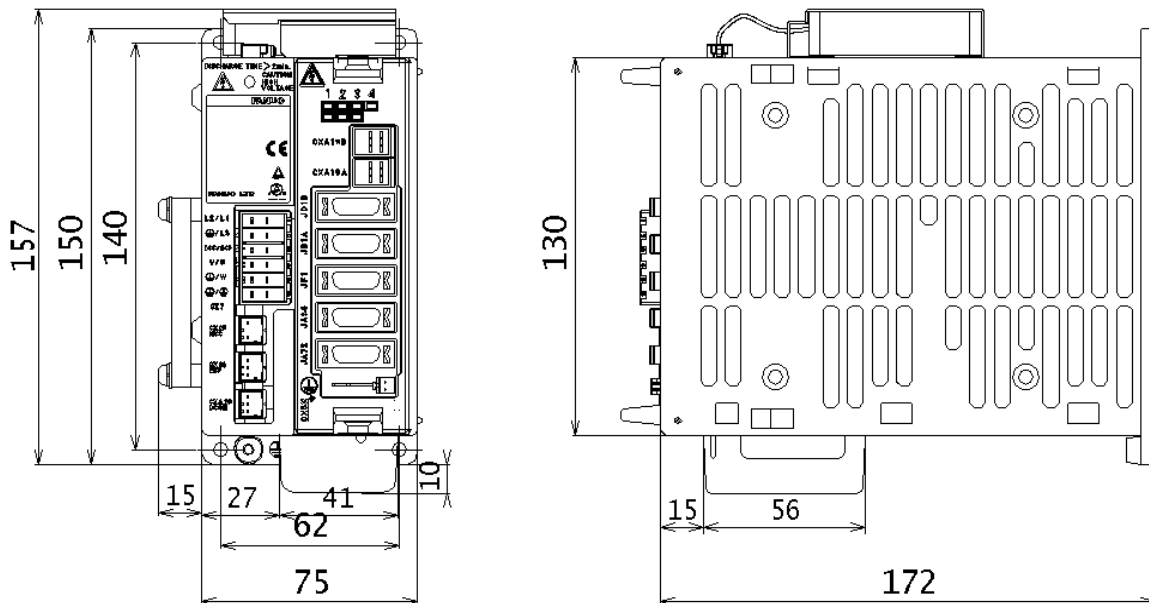

8.1.3 Fan Unit (A06B-6134-K002)

See Subsection 8.1.4 "External Dimensions of Fan Unit (A06B-6134-K002)" in Part I.

8.1.4 Separated Regenerative Discharge Resistor

See Subsection 8.1.5 "Discharge Resistor" in Part I.

8.1.5 AC Line Filter

See Subsection 8.1.6 "AC Line Filter" in Part I.

8.1.6 Transformer for Exports

See Subsection 8.1.7 "Transformer for Exports" in Part I.

8.1.7 Battery Case (for Size D Alkaline Battery)

See Subsection 8.1.8 "Battery Case" in Part I.

8.1.8 Lightning Surge Absorbers

See Subsection 8.1.9 "Lightning Surge Absorbers" in Part I.

8.2 PANEL CUT-OUT DRAWINGS

See Section 8.2 "PANEL CUT-OUT DRAWINGSS" in Part I.

8.3 MAINTENANCE AREA

8.3.1 Maintenance Area for the SVM1-4i and SVM1-20i

The maintenance area varies depending on whether the separated regenerative discharge unit (A06B-6130-H401) is used or not. For details, see the figure below. The maintenance area when the separated regenerative discharge unit (A06B-6130-H401) is installed is shown on the left side of the figure, and the maintenance area when the separated regenerative discharge unit (A06B-6130-H401) is not installed is shown on the right side. When the battery for the absolute pulse coder (dedicated lithium battery) is installed, the same maintenance area applies.

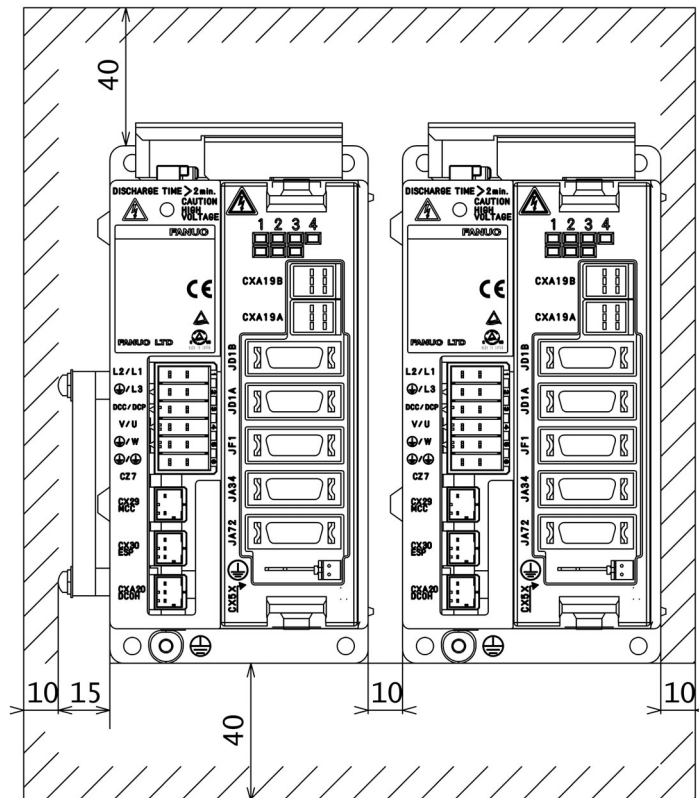

8.3.2 Maintenance Area for the SVM1-40i

See "When no cooling fan AC motor (A06B-6134-K002) is used to cool the heat sink" in Subsection 8.3.2, "Maintenance Area for the SVM1-40i and SVM1-80i" in Part I.

8.3.3 Maintenance Area for the SVM1-80i

See "When the cooling fan AC motor (A06B-6134-K002) is used to cool the heat sink" in Subsection 8.3.2, "Maintenance Area for the SVM1-40i and SVM1-80i" in Part I.

9

TOTAL CONNECTION DIAGRAM

9.1 CONNECTION DIAGRAM

9.1.1 SVM1-4i and SVM1-20i

This subsection shows a connection example of a 2-axis system using two SVM units which are the SVM1-4i or SVM1-20i.

In this example, a separated regenerative discharge unit is connected but no external pulse generator is connected to the SVM unit for the first axis (the unit nearer the CNC), while no separated regenerative discharge unit is connected but an external pulse generator is connected to the SVM unit for the second axis.

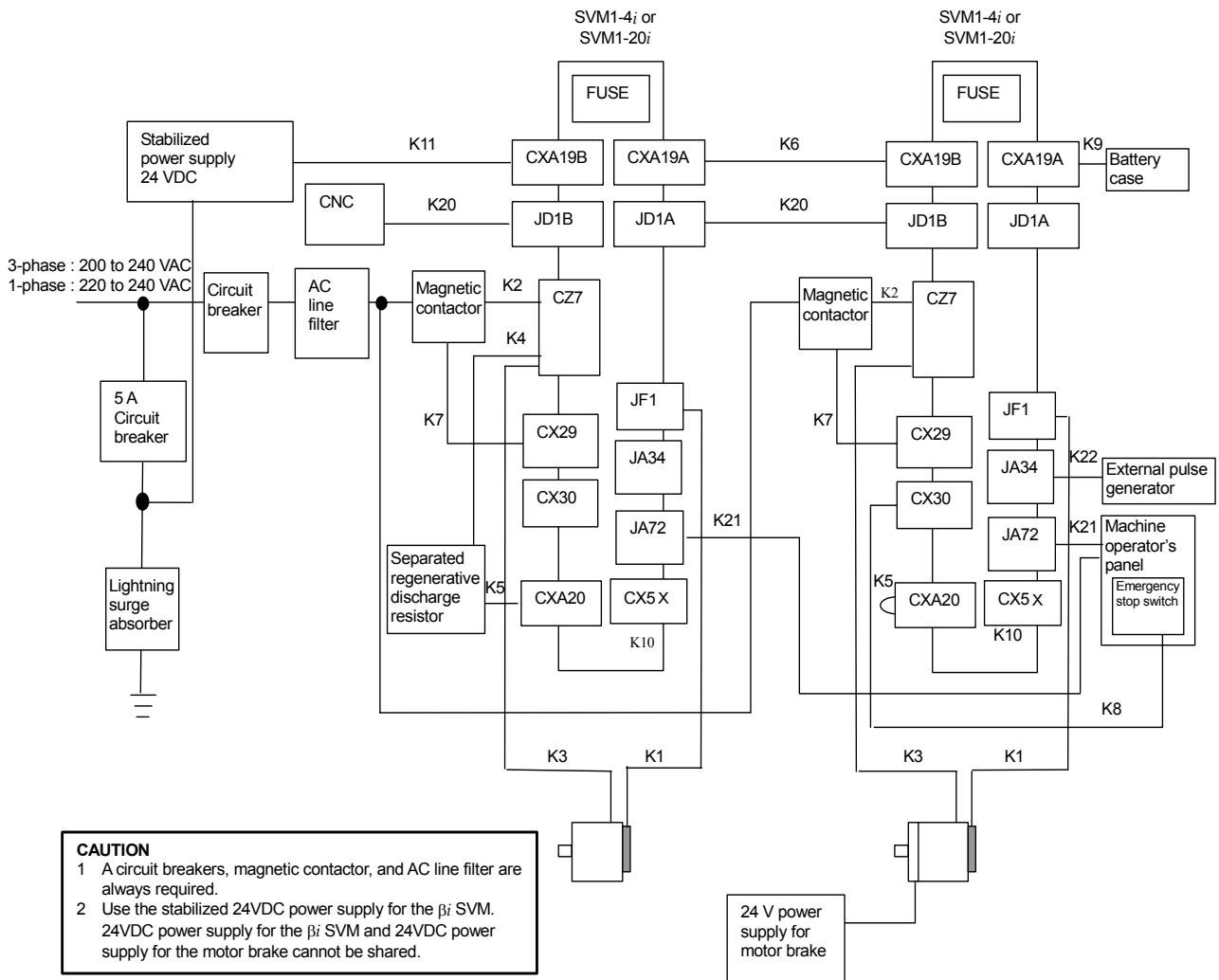

CAUTION

- 1 A circuit breakers, magnetic contactor, and AC line filter are always required.
- 2 Use the stabilized 24VDC power supply for the βi SVM. 24VDC power supply for the βi SVM and 24VDC power supply for the motor brake cannot be shared.

NOTE

- 1 Always install the circuit breakers, magnetic contactor, and AC line filter.
- 2 To protect the equipment from lightning surge voltages, install a lightning surge absorber across each pair of power lines and across each power line and the grounding line at the power inlet of the power magnetics cabinet.

**WARNING**

Defects, such as a loose screw and an incorrectly inserted connector, can lead to a motor malfunction, excessive heat generation, and a ground fault.

Exercise adequate care in installing servo amplifiers.

A loose screw (or, if a connector is used, a loose connector contact or an incorrect connector pin-to-cable connection) on high-current carrying power supply wires or motor power wires can lead to fire. Exercise adequate care in wiring.

9.1.2 SVM1-40i and SVM1-80i

This subsection shows a connection example of a 2-axis system using the SVM1-80i for the first axis (the unit nearer the CNC) and the SVM1-40i for the second axis.

In this example, a separated regenerative discharge unit is connected but no external pulse generator is connected for the first axis, while no separated regenerative discharge unit is connected but an external pulse generator is connected for the second axis.

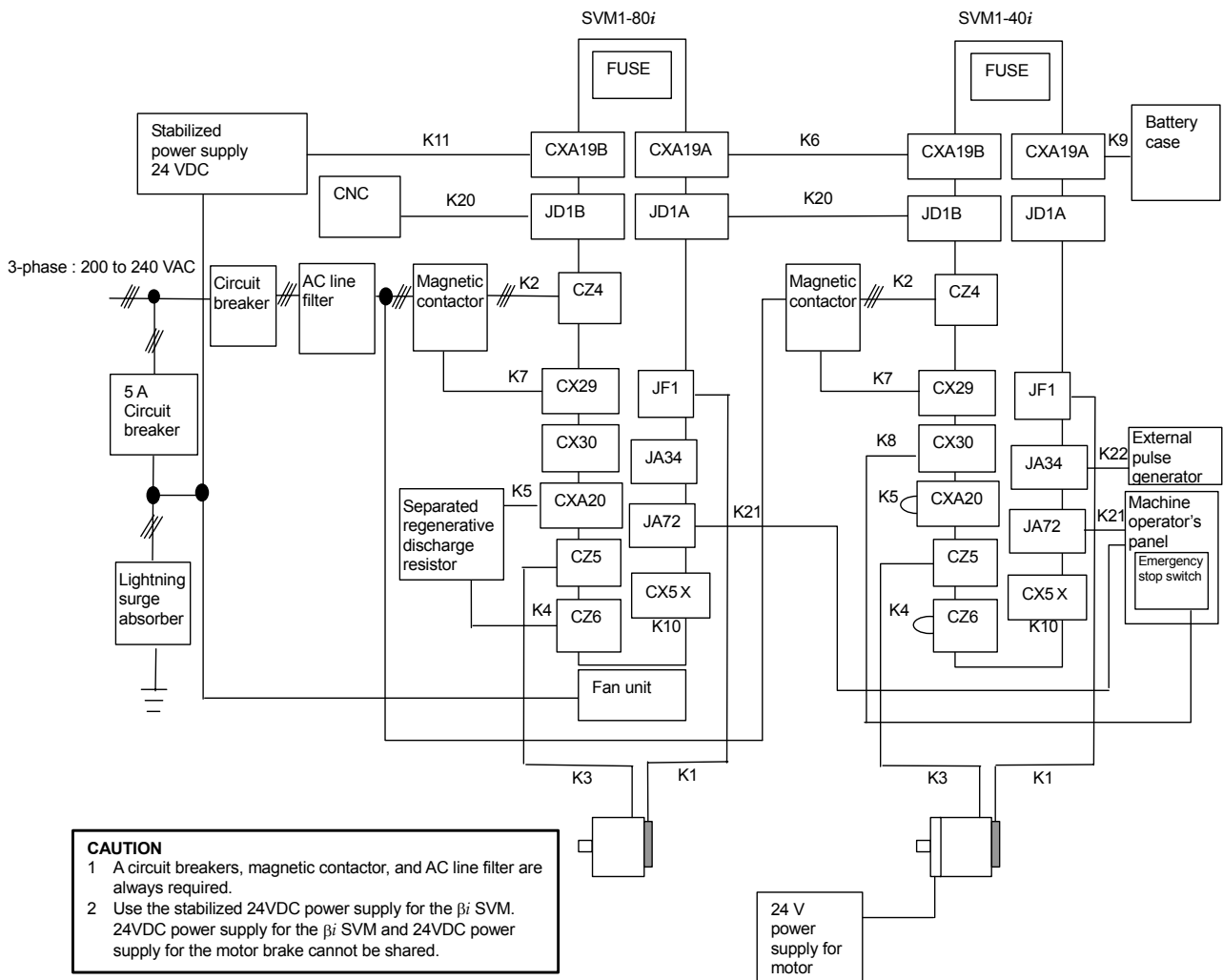

NOTE

- 1 Always install the circuit breakers, magnetic contactor, and AC line filter.
- 2 To protect the equipment from lightning surge voltages, install a lightning surge absorber across each pair of power lines and across each power line and the grounding line at the power inlet of the power magnetics cabinet.

**WARNING**

Defects, such as a loose screw and an incorrectly inserted connector, can lead to a motor malfunction, excessive heat generation, and a ground fault.

Exercise adequate care in installing servo amplifiers.

A loose screw (or, if a connector is used, a loose connector contact or an incorrect connector pin-to-cable connection) on high-current carrying power supply wires or motor power wires can lead to fire. Exercise adequate care in wiring.

9.1.3 SVM1-4i and SVM1-20i

Example for sharing a magnetic contactor

This subsection shows a connection example of a 2-axis system using two SVM units which are the SVM1-4i or SVM1-20i.

In this example, a separated regenerative discharge unit is connected but no external pulse generator is connected to the SVM unit for the first axis (the unit nearer the CNC), while no separated regenerative discharge unit is connected but an external pulse generator is connected to the SVM1 unit for the second axis.

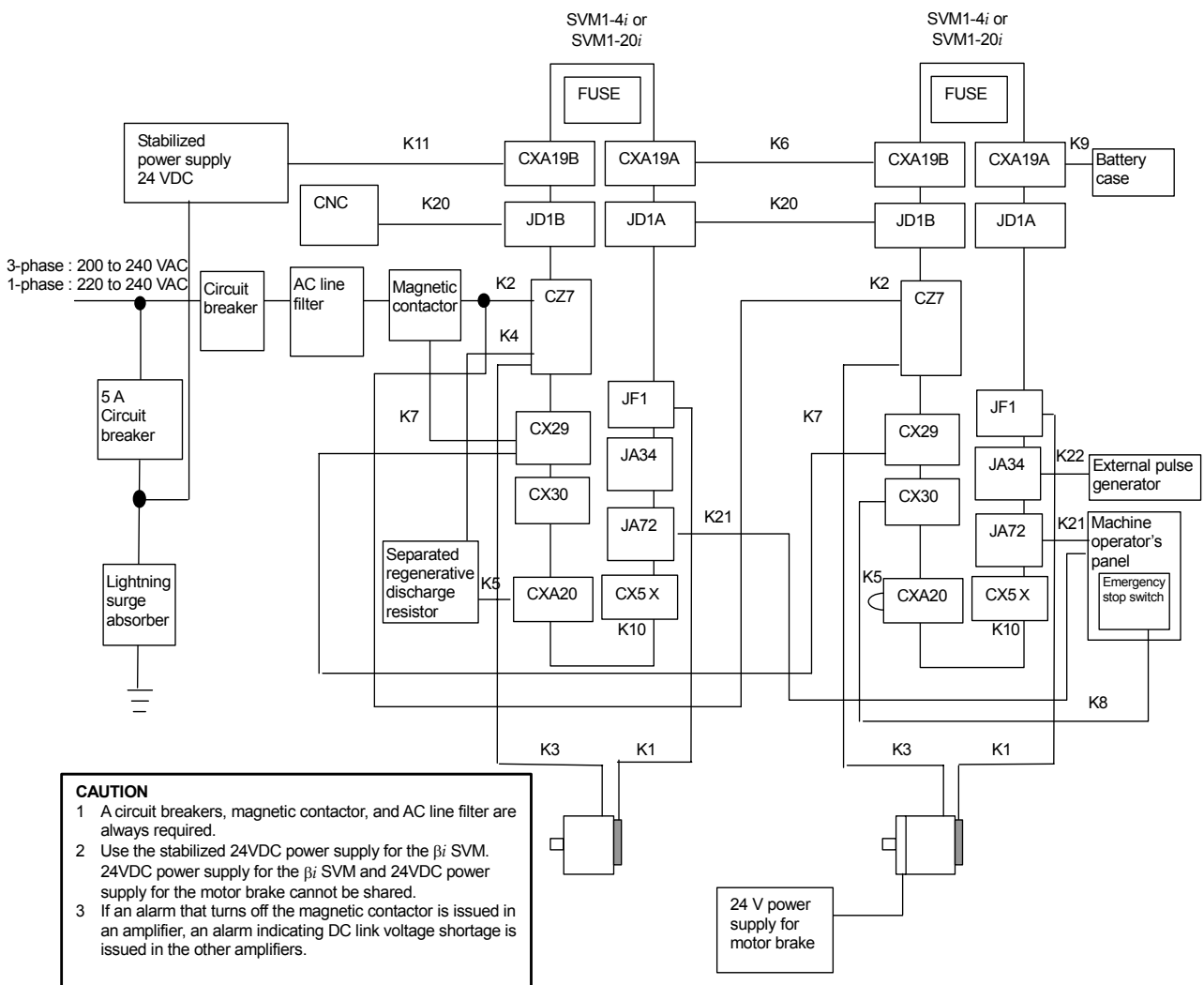

NOTE

- 1 Always install the circuit breakers, magnetic contactor, and AC line filter.
- 2 To protect the equipment from lightning surge voltages, install a lightning surge absorber across each pair of power lines and across each power line and the grounding line at the power inlet of the power magnetics cabinet.

**WARNING**

Defects, such as a loose screw and an incorrectly inserted connector, can lead to a motor malfunction, excessive heat generation, and a ground fault.

Exercise adequate care in installing servo amplifiers.

A loose screw (or, if a connector is used, a loose connector contact or an incorrect connector pin-to-cable connection) on high-current carrying power supply wires or motor power wires can lead to fire. Exercise adequate care in wiring.

9.1.4 SVM1-40i and SVM1-80i

Example for sharing a magnetic contactor

This subsection shows a connection example of a 2-axis system using the SVM1-80i for the first axis (the unit nearer the CNC) and the SVM1-40i for the second axis.

In this example, a separated regenerative discharge unit is connected but no external pulse generator is connected for the first axis, while no separated regenerative discharge unit is connected but an external pulse generator is connected for the second axis.

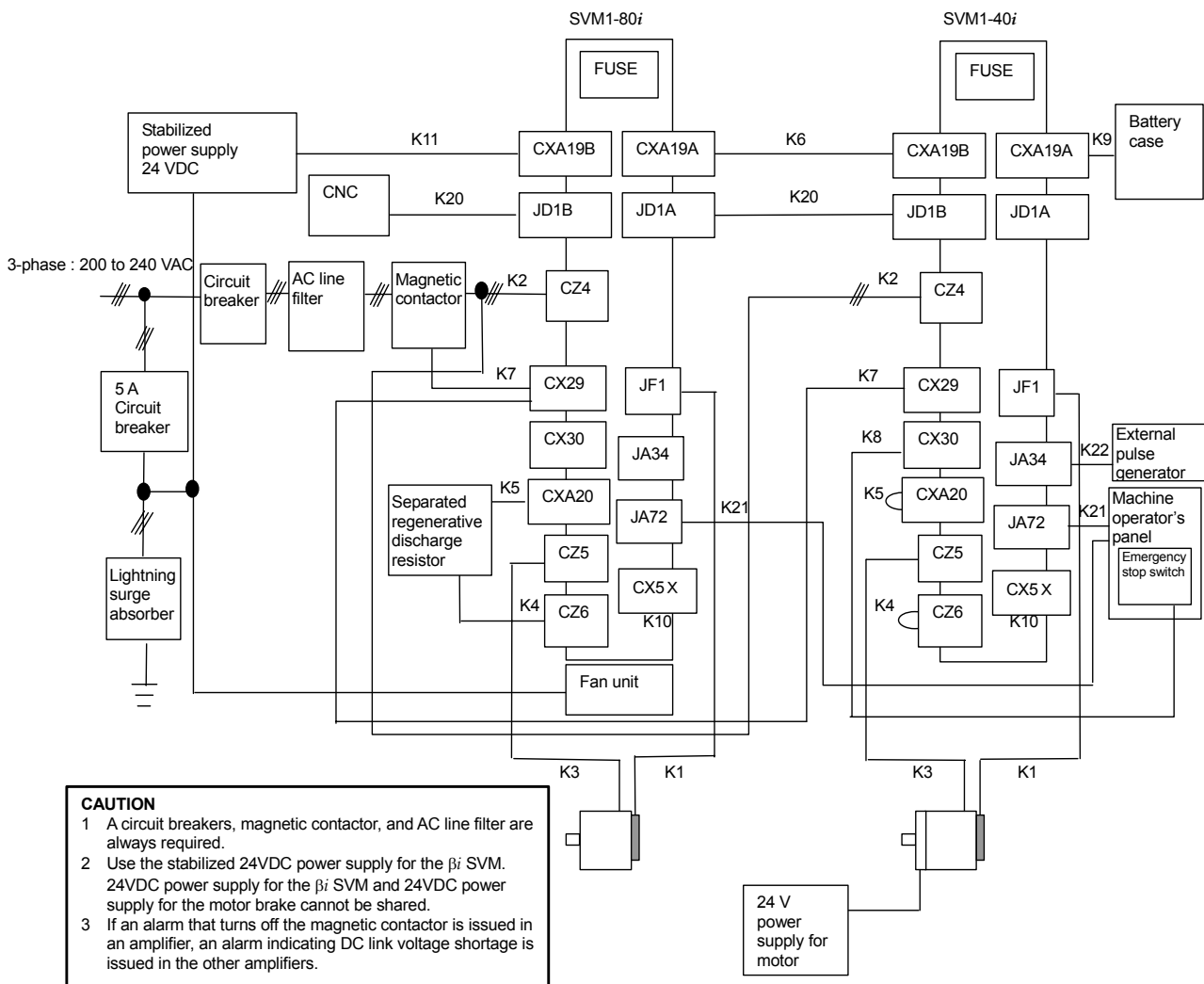

NOTE

- 1 Always install the circuit breakers, magnetic contactor, and AC line filter.
- 2 To protect the equipment from lightning surge voltages, install a lightning surge absorber across each pair of power lines and across each power line and the grounding line at the power inlet of the power magnetics cabinet.

**WARNING**

Defects, such as a loose screw and an incorrectly inserted connector, can lead to a motor malfunction, excessive heat generation, and a ground fault.

Exercise adequate care in installing servo amplifiers.

A loose screw (or, if a connector is used, a loose connector contact or an incorrect connector pin-to-cable connection) on high-current carrying power supply wires or motor power wires can lead to fire. Exercise adequate care in wiring.

9.2 CONNECTOR LOCATION

9.2.1 SVM1-4i and SVM1-20i

No.	Name	Remarks
1		DC link charge LED
2	CZ7-1 CZ7-2	Main power input connector
3	CZ7-3	Discharge register connector
4	CZ7-4 CZ7-5 CZ7-6	Motor power connector
5	CX29	Connector for main power MCC control signal
6	CX30	ESP signal connection connector
7	CXA20	Regenerative resistor connector (for alarms)
8	LED	LED for status display
9	CXA19B	24VDC power input
10	CXA19A	24VDC power output
11	JD1B	Connector for I/O Link (to previous stage)
12	JD1A	Connector for I/O Link (to following stage)
13	JF1	Connector for Pulsecoder
14	JA34	Connector for external pulse input
15	JA72	Connector for built-in DI
16	CX5X	Absolute Pulsecoder battery
17	Signal grounding terminal	Grounding terminal of control section
18		Tapped hole for grounding the flange

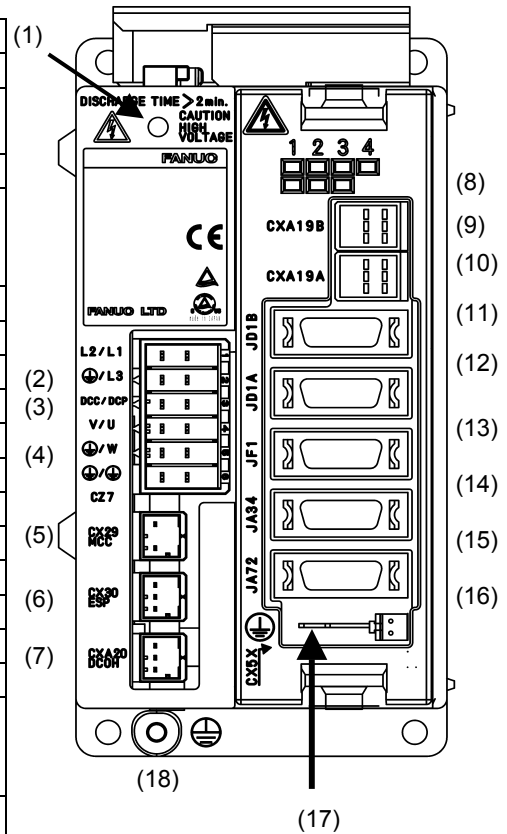

9.2.2 SVM1-40i and SVM1-80i

No.	Name	Remarks
1		DC link charge LED
2	CX29	Connector for main power MCC control signal
3	CX30	ESP signal connection connector
4	CXA20	Regenerative resistor connector (for alarms)
5	SW	Setting switch (DC alarm level)
6	CZ4	Main power input connector
7	CZ5	Motor power connector
8	CZ6	Discharge register connector
9	LED	LED for status display
10	CXA19B	24VDC power input
11	CXA19A	24VDC power output
12	JD1B	Connector for I/O Link (to previous stage)
13	JD1A	Connector for I/O Link (to following stage)
14	JF1	Connector for Pulsecoder
15	JA34	Connector for external pulse input
16	JA72	Connector for built-in DI
17	CX5X	Absolute Pulsecoder battery
18	Signal grounding terminal	Grounding terminal of control section
19		Tapped hole for grounding the flange

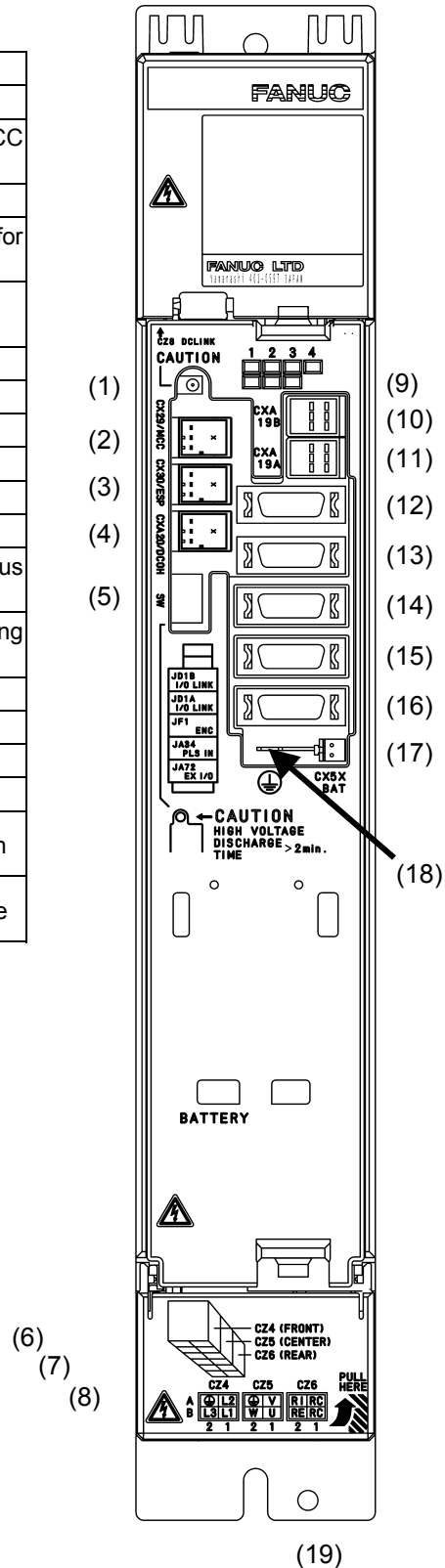

9.2.3 Connection Tools

See Subsection 9.2.3 "Connection Tools" in Part I.

9.2.4 Details of Cable K1

9.2.4.1 Servo motor αi , αis series, Servo motor βis series ($\beta 0.4/5000is$ to $\beta 22/2000is$)

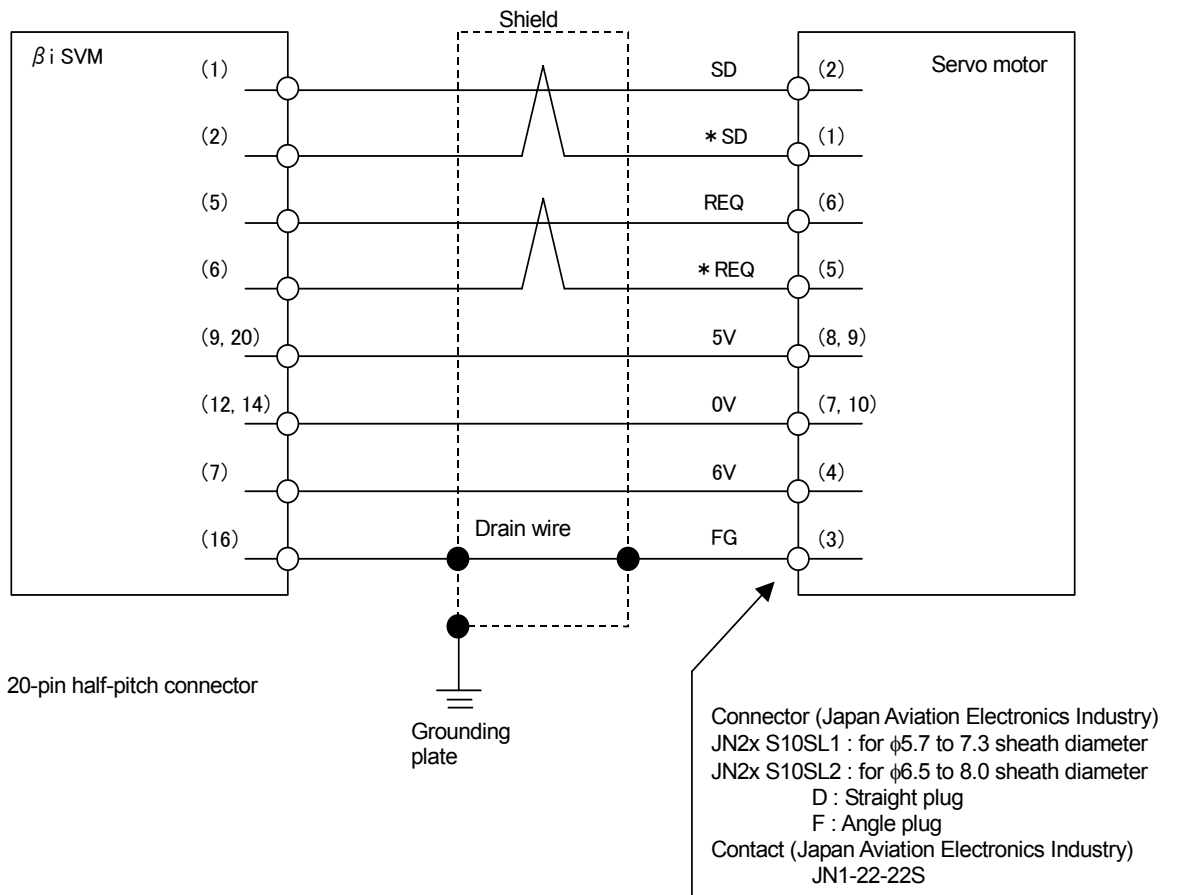

Using cable conductor

Cable length	28 m or less	50 m or less
5V, 0V, 6V	0.3mm ² × 5 Wire construction 12/0.18 or 60/0.08 Insulation outer diameter $\phi 1.5$ or less	0.5mm ² × 5 Wire construction 20/0.18 or 104/0.08 Insulation outer diameter $\phi 1.5$ or less
SD, *SD, REQ, *REQ	0.18mm ² or more Twisted-pair wire	0.18mm ² or more Twisted-pair wire
Drain wire	0.15mm ² or more	0.15mm ² or more

* This applies also to the αMi and αCi series servo motors.

NOTE

- 1 Place the grounding plate to which the shield is connected at a nearby position of the βi SVM to minimize the distance between the βi SVM and the grounding plate.
- 2 In case that the cable is prepared by MTB, total resistance of 5V and 0V must be less than 2Ω .
- 3 Pulsecoder side connector can accept maximum 0.5mm^2 (wire construction 20/0.18 or 104/0.08, insulation outer diameter $\phi 1.5$ or less) wire and sheath diameter is $\phi 5.7$ to $\phi 8.0$. In case of using thicker wire or cable, take measures described below.

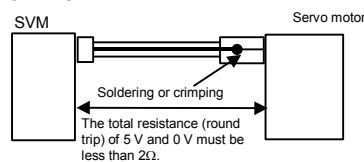
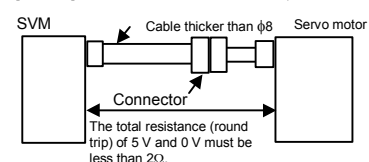
[Case 1] Cable conductor exceeds 0.5mm^2 .[Case 2] Sheath diameter of exceeds $\phi 8$.

- 4 In case of incremental Pulsecoder, 6V is not necessary to be connected.

- Crimp tool specification
A06B-6114-K201/JN1E : For 0.18mm^2 or 0.3mm^2
A06B-6114-K201/JN1D : For 0.18mm^2 or 0.5mm^2
- Connector kit specification
A06B-6114-K204/S : Straight plug (including a contact)
A06B-6114-K204/E : Elbow plug (including a contact)
- Recommended cable
A66L-0001-0479 : Flexible cable 28 m or less long
A66L-0001-0488 : Flexible cable 50 m or less long

9.2.4.2 Servo motor βis series ($\beta 0.2/5000is$, $\beta 0.3/5000is$)

See Subsection 9.2.4.2 "Servo motor βis series ($\beta 0.2/5000is$, $\beta 0.3/5000is$)" in Part I.

9.2.5 Details of Cable K2

See Subsection 9.2.5 "Details of Cable K2" in Part I.

9.2.6 Details of Cable K3

See Subsection 9.2.6 "Details of Cable K3" in Part I.

9.2.7 Details of Cables K4 and K5

See Subsection 9.2.7 "Details of Cables K4 and K5" in Part I.

9.2.8 Details of Cable K6

See Subsection 9.2.8 "Details of Cable K6" in Part I.

9.2.9 Details of Cable K7

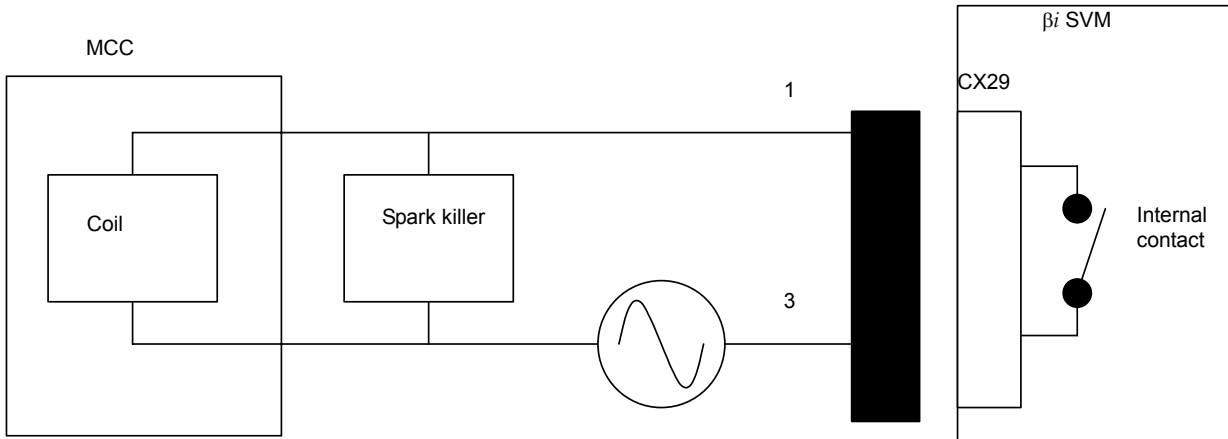

External power supply
(Use an appropriate power supply for the coil voltage the customer uses.)

D-2000 series
Housing : 3-1318130-3
Contact : 1318107-1
Applicable wire: 0.3 to 0.85 mm²
Manufacture : Tyco Electronics AMP

For connection tools, see Subsection 9.2.3 in Part I.

Internal contact capacity

	Resistance load (COS ϕ =1)	Inductive load (COS ϕ =0.4, L/R=15msec)
Rated load	AC250V, 3A/ DC24V, 5A	AC250V, 2A/ DC24V, 1A
Maximum contact capacity	5A	5A

NOTE

- 1 To protect the internal contact, be sure to insert a spark killer (CR) that matches the magnetic contactor used.
- 2 It is recommended that one MCC be installed per β i SVM unit.

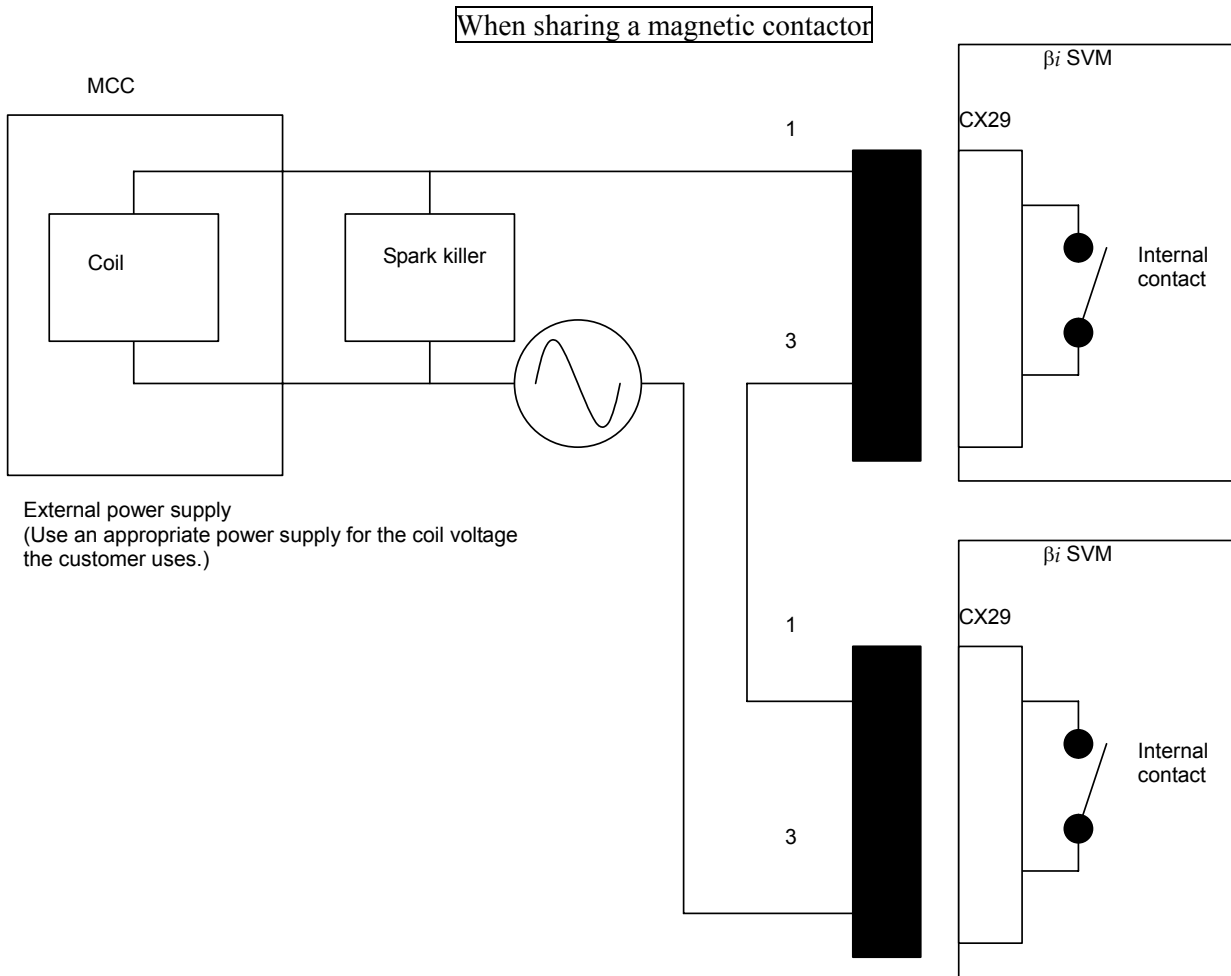

9.2.9.1 Connection of external magnetic contactor when βi SVM FSSB interface is used together

See Section 9.3 "HANDLING OF EXTERNAL MAGNETIC CONTACTORS" in Part I.

9.2.10 Details of Cable K8

See Subsection 9.2.10 "Details of Cable K8" in Part I.

9.2.11 Details of Cable K9

See Subsection 9.2.11 "Details of Cable K9" in Part I.

9.2.12 Details of Cable K10

See Subsection 9.2.12 "Details of Cable K10" in Part I.

9.2.13 Details of Cable K11

See Subsection 9.2.13 "Details of Cable K11" in Part I.

9.2.14 Details of Cable K20 (Connection of FANUC I/O Link)

9.2.14.1 Overview

The FANUC I/O Link is a serial interface that connects a CNC, β i SVM, I/O Unit-A, Power Mate CNC, and other units to transfer I/O signals (bit data) between these units at high speed. When units are connected by the FANUC I/O Link, one of the units serves as a master, and the other units serve as slaves. The status of input signals from the slaves is transferred to the master at regular intervals, and an output signal from the master is transferred to the slaves at regular intervals. The β i SVM can function as a slave only. It has 128 input signals and 128 output signals.

The connectors of the I/O Link are named JD1A (or JD1A1) and JD1B, which are common to all units having the I/O Link function. Every cable must be connected from JD1A (or JD1A1) to JD1B. JD1A of the last unit is connected to nothing, so it is left open. It need not be connected to a terminator or the like.

Electric cables or optical fiber cables are used for I/O Link connection. In the following cases, use optical fiber cables:

- The cable length is 10 m or longer. When units are located within the same cabinet, the cable length is 15 m or longer. When a cable is installed in a duct, the units connected at both ends of the cable should be assumed to be within the same cabinet. For example, suppose that a CNC serving as the host is placed on the operator's panel, the β i SVM is placed in the power magnetics cabinet, and the I/O Link cable connecting these units is passed through a duct. In this case, the CNC and β i SVM are assumed to be within the same cabinet.
- A cable is routed between different cabinets, and it is impossible to connect the cabinets with a 5.5-mm² or thicker ground cable.
- There is a possibility that a cable is affected by noise significantly. For example, there is a strong electromagnetic noise source such as a welding machine near the cable, or a cable generating noise such as a power cable or a power magnetics cable is laid in parallel to the cable over a long distance.

9.2.14.2 Connection of FANUC I/O Link by electric cable

Details of connection by cable K20 (when the β i SVM is connected to the host controller or the preceding slave unit)

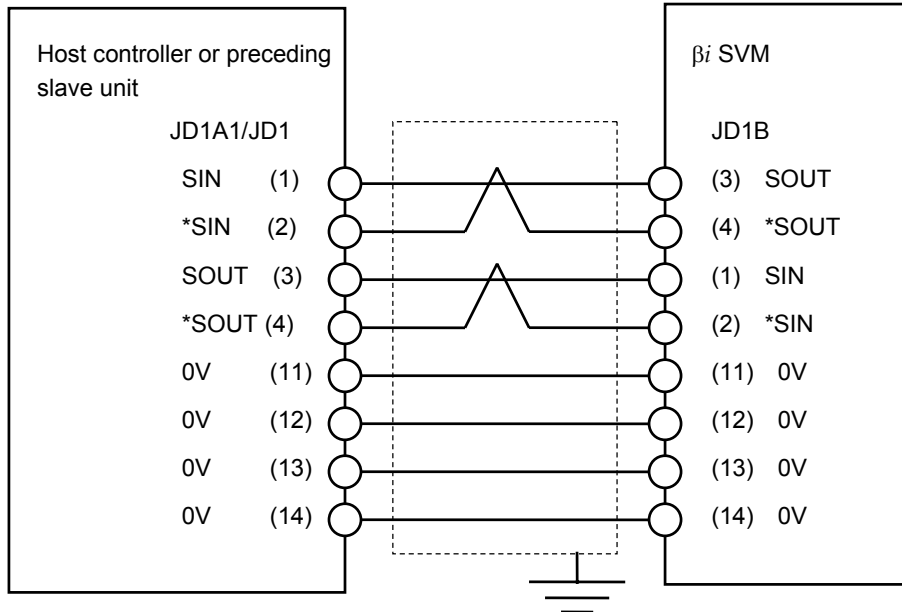

Details of connection by cable K20 (when connected to the following slave unit)

When a slave unit follows, connect the unit as follows:

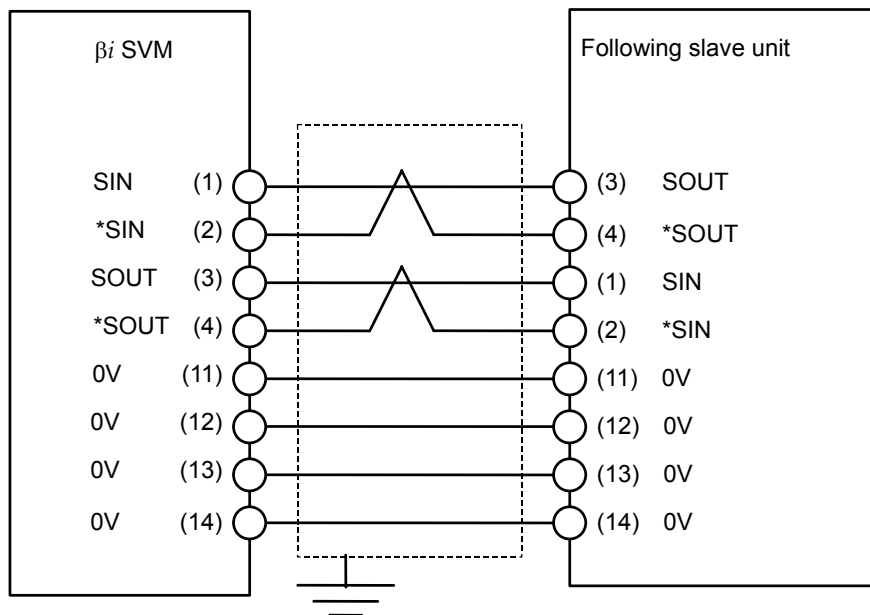

Specifications of recommended connector and case of cable K20 on the βi SVM side

Connector: PCR-E20FS (soldering type) (Honda Tsushin)
PCR-E20FA (crimp type)

Case: PCR-V20L

Recommended cable for cable K20

A66L-0001-0284#10P (10 twisted pairs, 28AWG, with common shield)

NOTE

- 1 Maximum cable length: 10m (when the above recommended cable is used)
- 2 Be sure to use twisted pairs to connect the SIN and *SIN signals and the SOUT and *SOUT signals in pairs.
- 3 Except the pins indicated in the above figure, leave pins open. Never connect unused conductors of the cable to these pins.
- 4 Connect the shield of the cable to the ground plate of the cabinet by using a cable clamp.
Regardless of whether the βi SVM is connected to the host controller (or the preceding slave unit) or the following slave unit, clamp the cable and process the shield properly as soon as the cable is drawn into the cabinet. When the host controller and the βi SVM are placed in different cabinets, shield processing must be performed in two places for one cable. Even when the cable is not drawn outside the cabinet, it must be clamped for shield processing in at least one place.

9.2.14.3 Connection of FANUC I/O Link by optical fiber cable

When an optical I/O Link adapter is used, FANUC I/O Link can be extended to up to 200 m by using optical fiber cables. For details, refer to the manual on the host controller.

9.2.15 Details of Cable K21 (Internal DI Connection)

9.2.15.1 Signals

The βi SVM has five DI signals. For the connection of the emergency stop signal, see Subsection 9.2.10, "Details of Cable K8" and Subsection 9.2.8, "Details of Cable K6". The other four DI signals are explained below.

(1) *+OT:

A + overtravel signal input.

When this signal is set to "logic 0", movement in the positive direction is disabled.

Use of this signal can be suppressed by parameter setting.

(2) *-OT:

A - overtravel signal input.

When this signal is set to "logic 0", movement in the negative direction is disabled.

Use of this signal can be suppressed by parameter setting.

(3) *RILK (*DEC):

An interlock signal input (*RILK) or a reference position return deceleration signal input (*DEC). One of these functions is selected by parameter setting. When the interlock signal input (*RILK) is selected, setting this signal to "logic 0" decelerates then stops axis movement operation. Setting this signal to "logic 1" resumes the operation. When the reference position return deceleration signal input (*DEC) is selected, setting this signal to "logic 0" decelerates the feedrate, then feed operation continues at a constant low feedrate. If the signal is then set to "logic 1", the feed operation stops as an electrical grid position is encountered.

(4) HDI:

Skip signal input.

The currently executed block is skipped at the rising edge or falling edge of this signal. Whether to use the rising edge or falling edge of the signal is determined by parameter setting.

9.2.15.2 *+OT, *-OT, and *RILK(*DEC)

Input signal specifications

The receiving circuit has a non-insulating interface that can switch between the sink type (24 V common) and the source type (0 V common). Safety standards require use of the sink type.

The contacts on the machine side must satisfy the following:

Contact capacity: 30 VDC, 16 mA or more

Leak current between contact points when a contact is closed:

1 mA or less (voltage: 26.4 V)

Voltage drop between contact points when a contact is closed:

2 V or less (current: 8.5 mA, including voltage drop in cable)

Signal connection to power magnetics cabinet

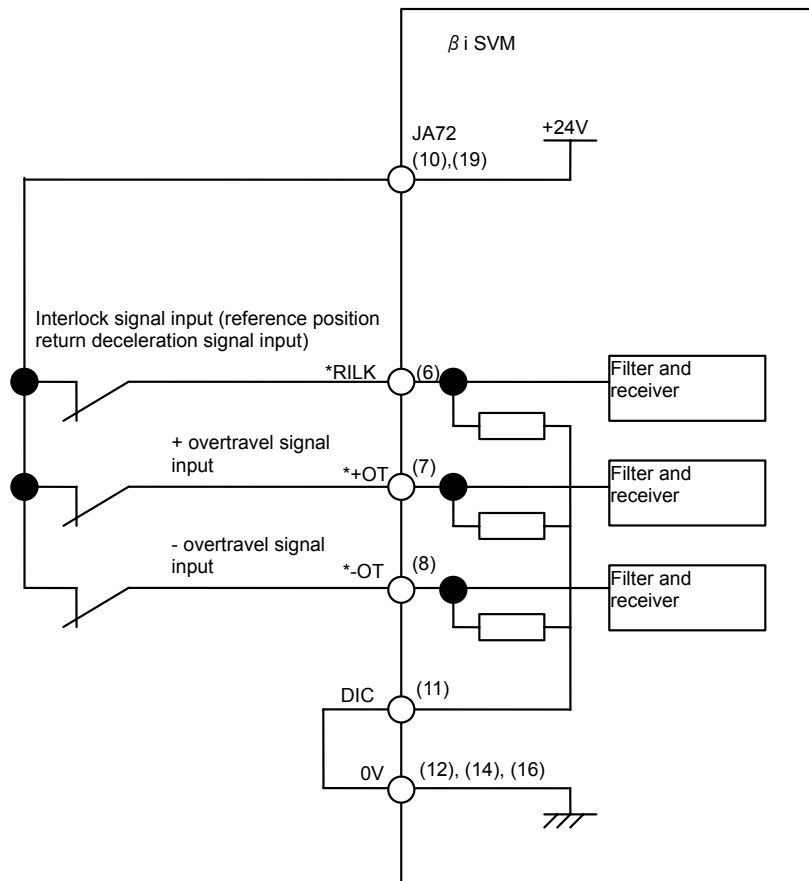

NOTE

- 1 Use a common shield cable as cable K21.
- 2 For 0V, +24V, and DIC, wires of at least 7/0.18 (0.18mm²) must be used.
- 3 Except the pins indicated in the above figure, leave pins open. Never connect unused conductors of the cable to these pins.
- 4 The above shows an example of the 24 V common type.
When the 0 V common type is used, connect DIC (JA72-11) to +24V (JA72-10, and 19), and the later stage of each switch to 0V (JA72-12, 14, and 16).

9.2.15.3 Skip signal interface

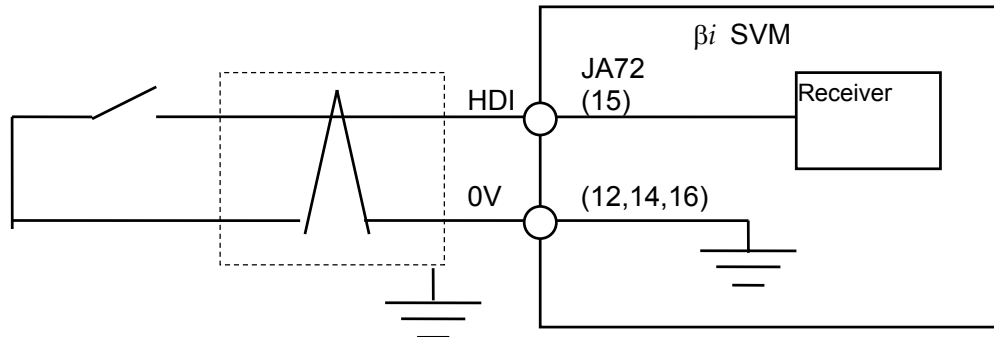

Input signal specifications

- Circuit configuration

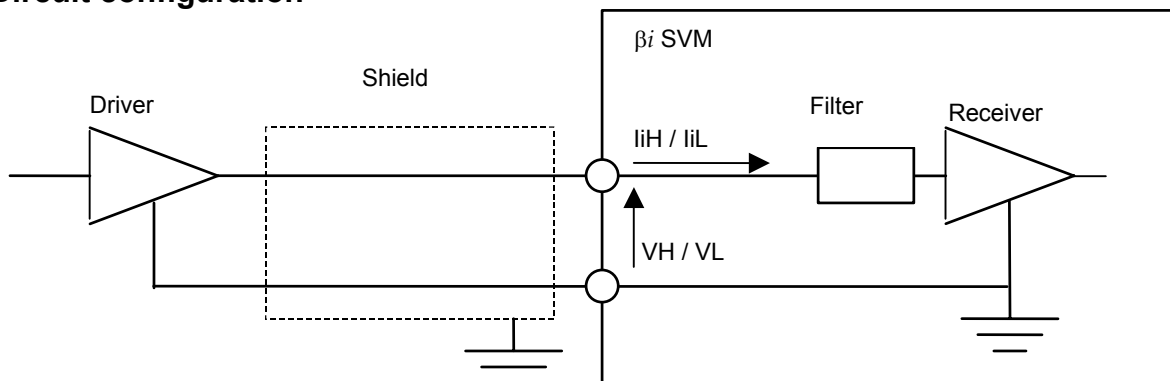

- Maximum absolute rating

Input voltage range V_{in} : -3.6 V to +13.6 V

- Input characteristics

Item	Signal	Specification	Unit	Remarks
High level input voltage	VH	3.6-11.6	V	
Low level input voltage	VL	0-0.55	V	
High level input current	liH	2 max	MA	Vin=5V
		11 max	MA	Vin=10V
Low level input current	liL	-8.0 max	MA	Vin=0V
Input signal pulse width		20 min	μs	

NOTE

The positive sign (+) of liH/liL indicates the direction in which current flows into the receiver, and the negative sign (-) indicates the direction in which current flows out of the receiver.

9.2.16 Connection to External Pulse Generator

The βi SVM can operate according to the pulse input from the outside. As the external pulse generator, a differential type A/B phase pulse generator that satisfies specifications or FANUC's manual pulse generator may be selected. When selecting the manual pulse generator, you need a manual pulse generator adapter (A06B-6093-D001).

One manual pulse generator can be connected to up to six βi SVM units. In this case, one manual pulse generator adapter is required per βi SVM unit.

When a differential type A/B phase pulse generator is used

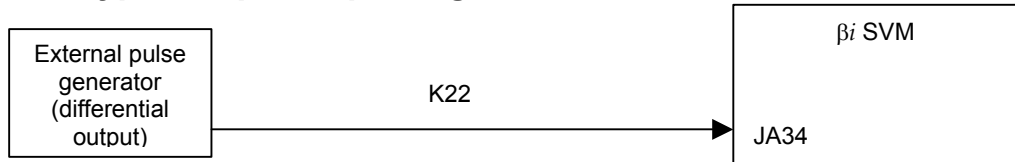

When FANUC's manual pulse generator is used (connected to βi SVM on a one-to-one basis)

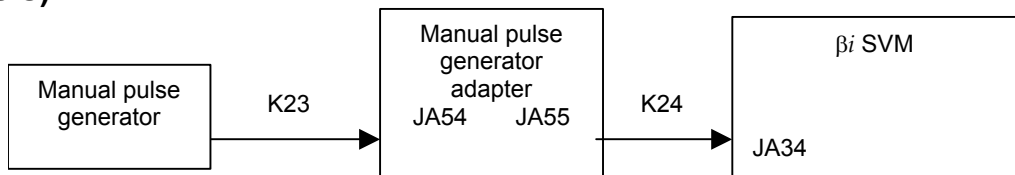

When FANUC's manual pulse generator is used (connected to more than one βi SVM)

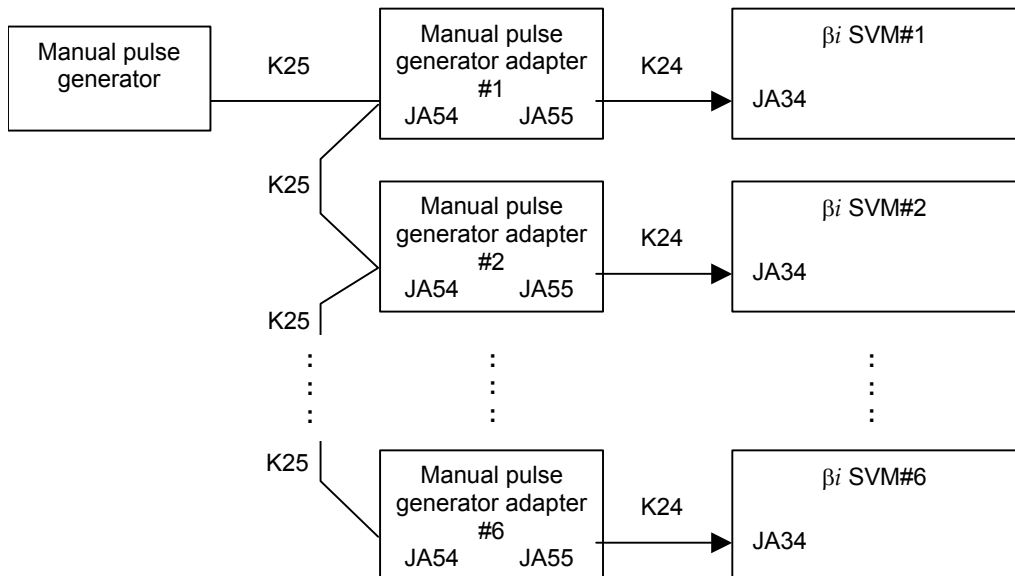

9.2.16.1 Connection when differential type A/B phase pulse generator is used

Details of cable K22

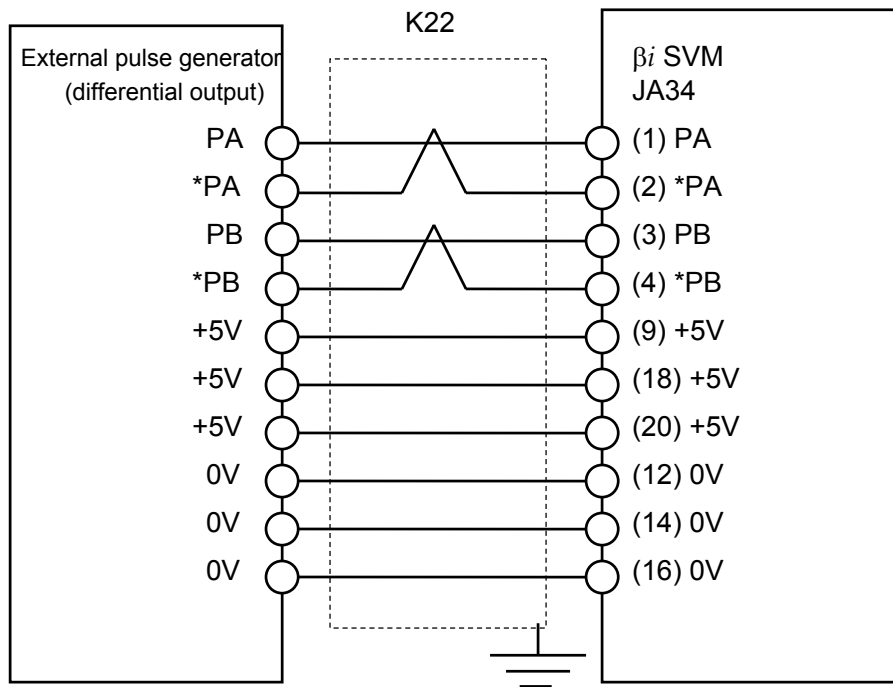

Connector: FI40-2015S (Hirose Electric Co., Ltd.)

Case: FI-20-CV (Hirose Electric Co., Ltd.)

Cable specification: Conductor 20/0.18 \times 6, 7/0.18 \times 3 pairs

Recommended cable:

A66L-0001-0286 (#20AWG \times 6 + #24AWG \times 6 + #24AWG \times 3 pairs)

NOTE

- 1 Power can be supplied from the βi SVM to the equipment if the equipment operates on +5 V and 0.35 A maximum.
In this case, pay attention to the power supply voltage drop due to cable resistance.
- 2 Be sure to use twisted pairs to connect the PA and *PA signals and the PB and *PB signals in pairs.
- 3 Except the pins indicated in the above figure, leave pins open. Never connect unused conductors of the cable to these pins.
- 4 Maximum cable length: 50 m

9.2.16.2 Connection when FANUC's manual pulse generator is used

Details of cable K23

Cable K23 is a signal cable used to connect the manual pulse generator and adapter (JA54).

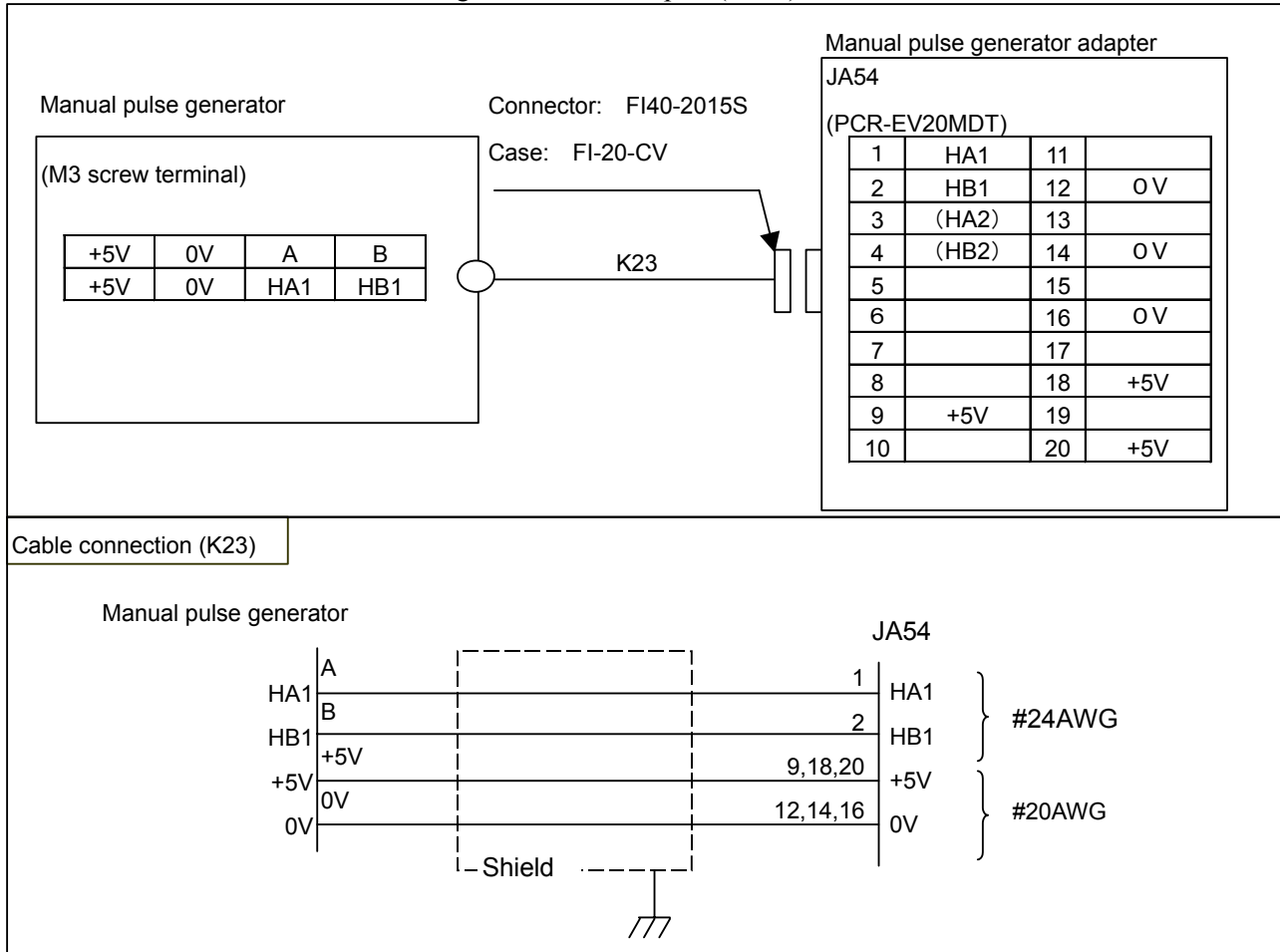

Recommended cable:

A66L-0001-0286 (#20AWG × 6 + #24AWG × 3 pairs)

Recommended connector (JA54 side)

Connector: FI40-2015S (Hirose Electric Co., Ltd.)

Case: FI-20-CV (Hirose Electric Co., Ltd.)

Recommended cable:

A02B-0259-K821 (7m) Change the connector name before use.

Although the maximum cable length is 50 m, the length is further limited because of the power supply voltage drop as follows:

Limitation due to power supply voltage drop

Suppress the power supply voltage drop due to the cable resistance to 0.2 V or less (the sum of the voltage drop of both the 0V and 5V lines). Perform calculation assuming that the power supply current of the manual pulse generator is 0.1 A.

In the calculations, the cable length must include the cable length of K24.

Details of cable K24

Cable K24 is a signal cable used to connect the manual pulse generator adapter (JA55) and the β i SVM (JA34).

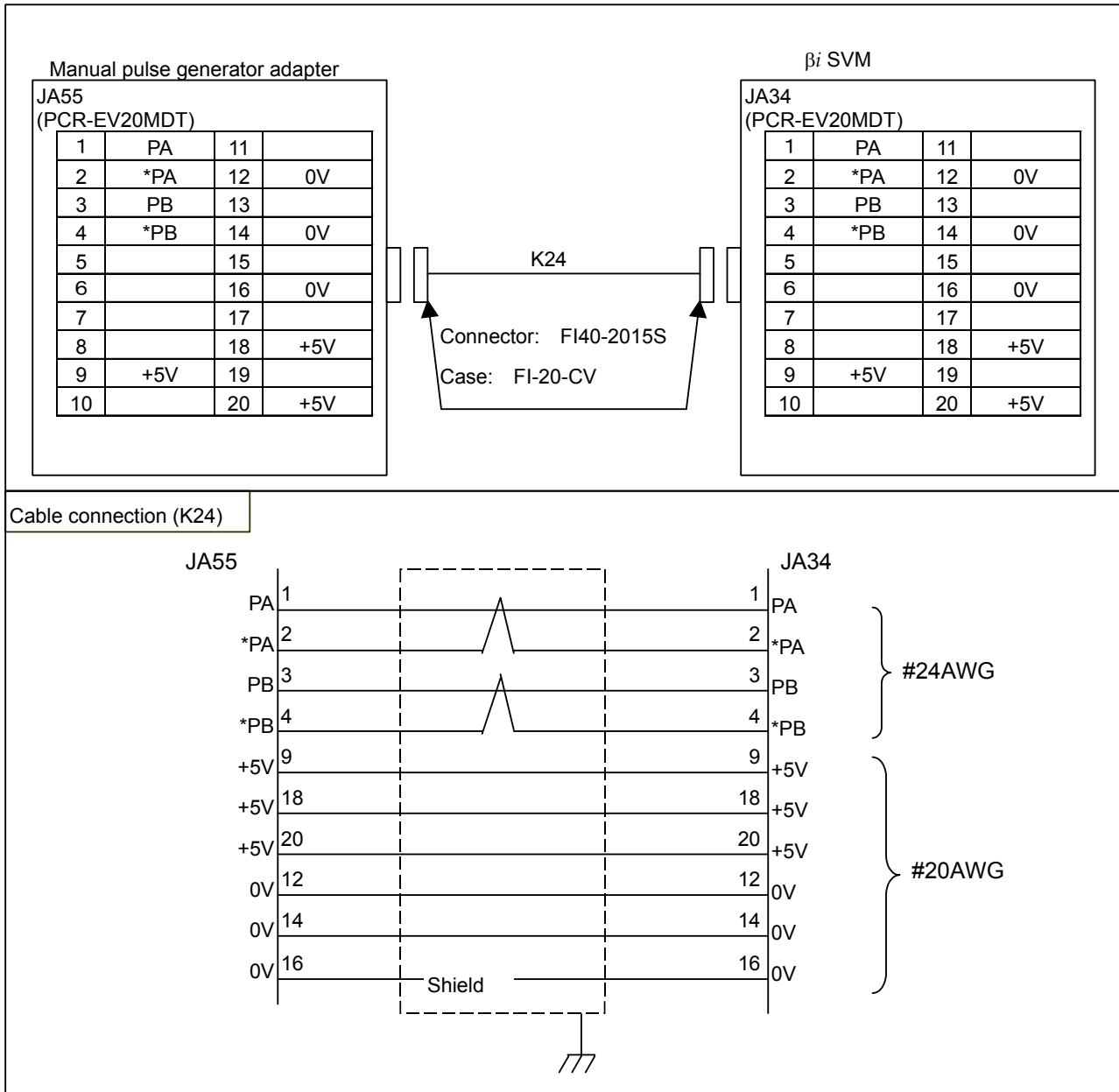

Recommended cable: A66L-0001-0286 (#20AWG \times 6 + #24AWG \times 3 pairs)

Recommended connector:

Connector: FI40-2015S (Hirose Electric Co., Ltd.)

Case: FI-20-CV (Hirose Electric Co., Ltd.)

The maximum cable length is 5 m.

Details of cable K25

Cable K25 is a signal cable used to connect the manual pulse generator and more than one manual pulse generator adapter (JA54).

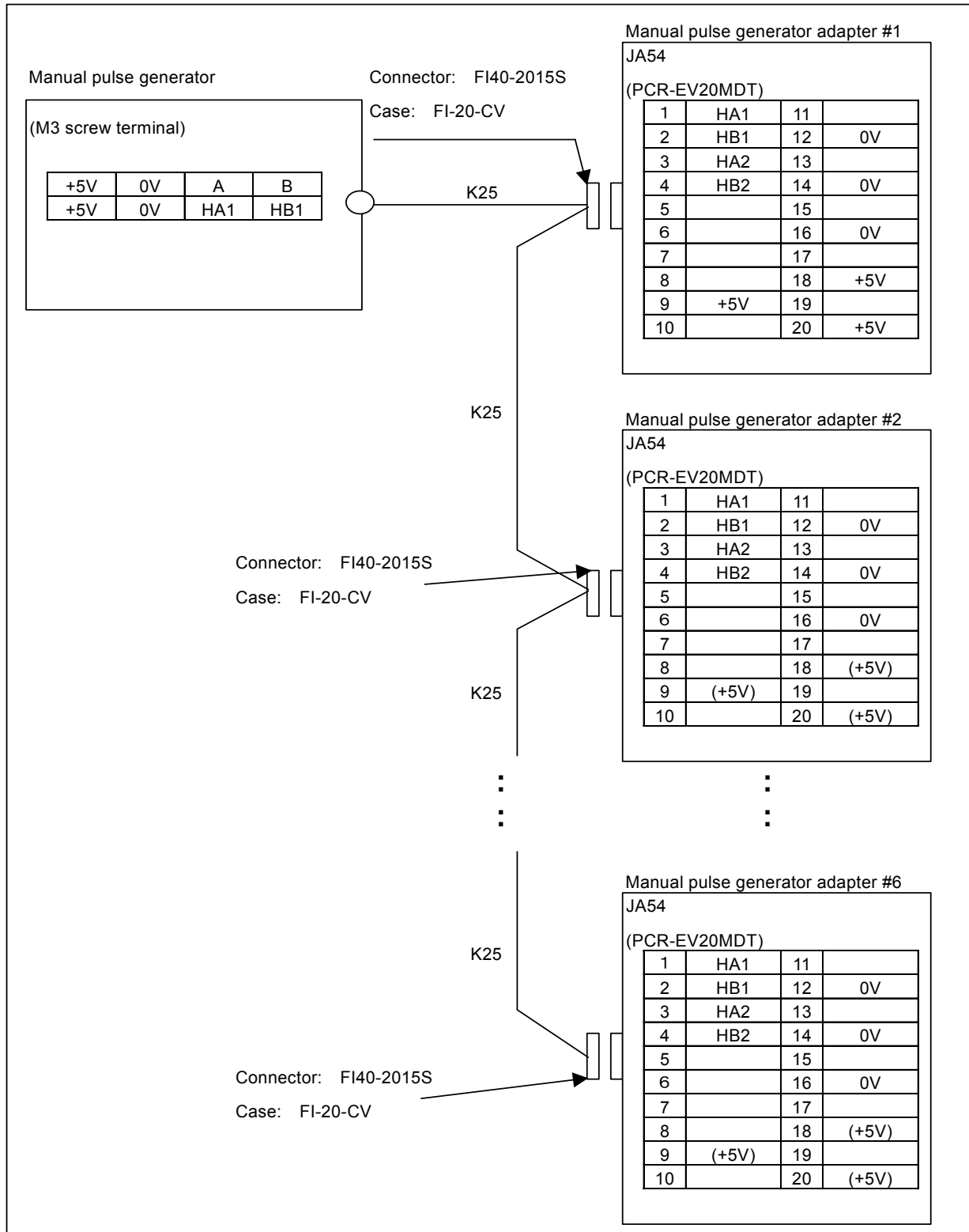

Cable connection (K25)
 The bold lines indicate that three conductors are used for connection.

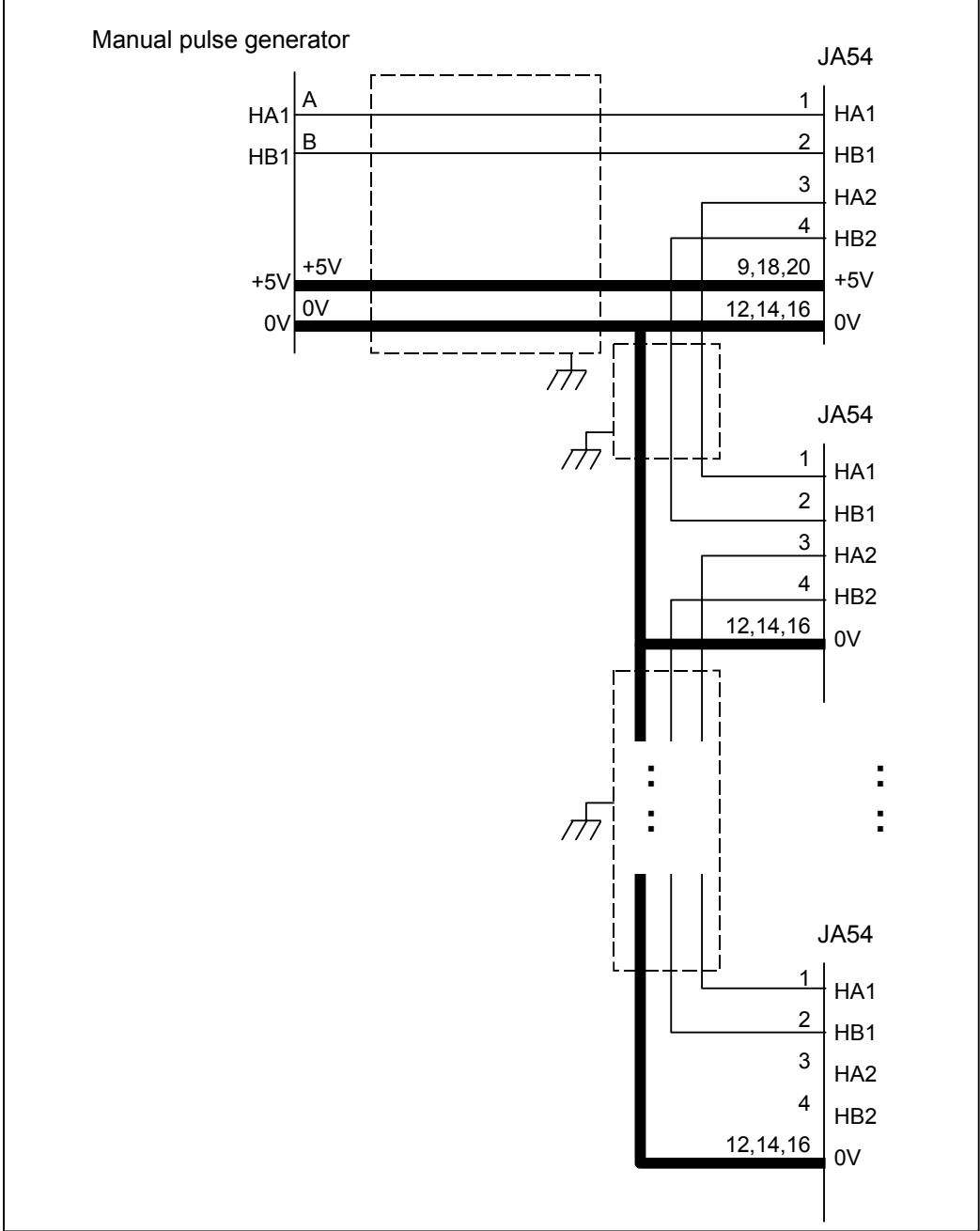

Manual pulse generator adapter

- Dimensions

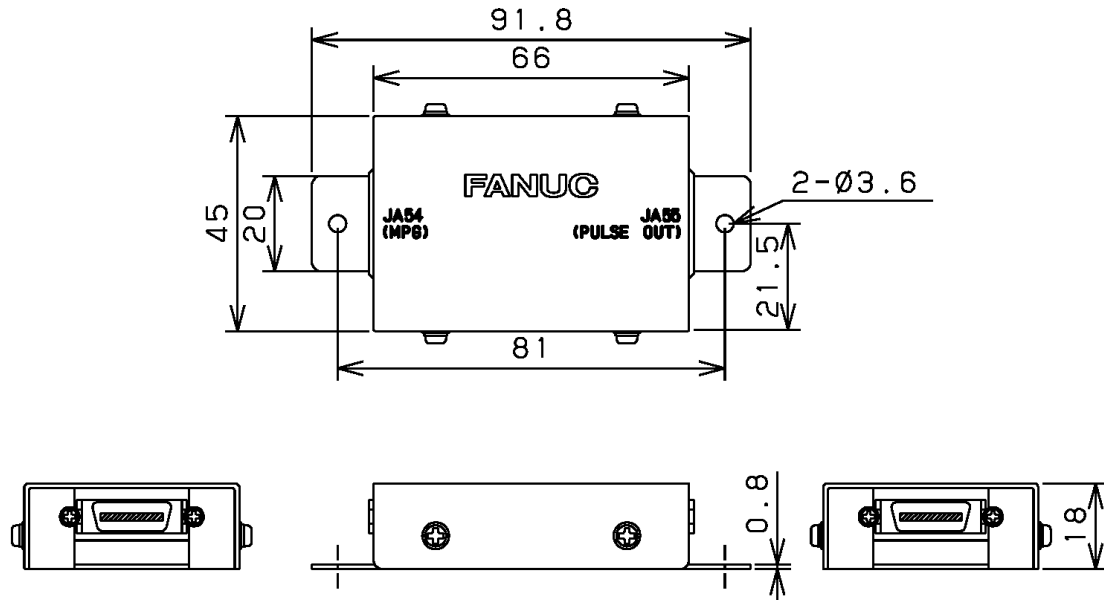

Weight: Approximately 100 g

- Installation condition

Because the manual pulse generator adapter does not have a sealed structure, it must be installed in a sealed cabinet similar to the cabinet of the βi SVM.

The manual pulse generator adapter has two 3.6-diameter holes. Use these holes to secure the adapter.

Because being lightweight, the manual pulse generator adapter need not be secured with screws. However, be careful not to allow the adapter to touch other electrical circuits to cause short-circuit.

Ground the case by using the case mounting screw of the manual pulse generator adapter.

- Operation conditions

The maximum allowable frequency of the input signals is 100 kHz. The βi SVM multiplies input pulses by four to obtain move commands. Therefore, up to 400 kpps is specified as a move command.

1) Positive direction move command pulse

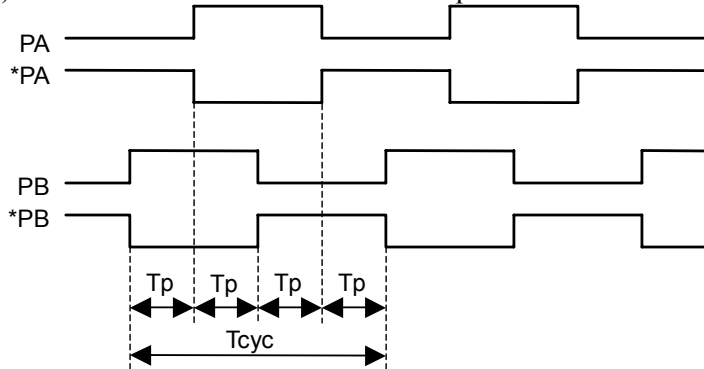

2) Negative direction move command pulse

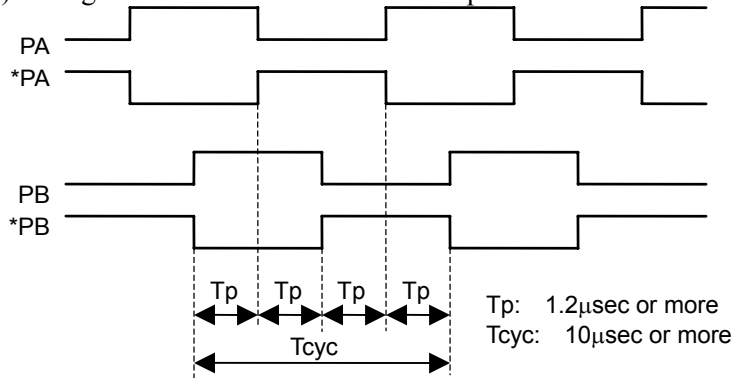

3) Sequence

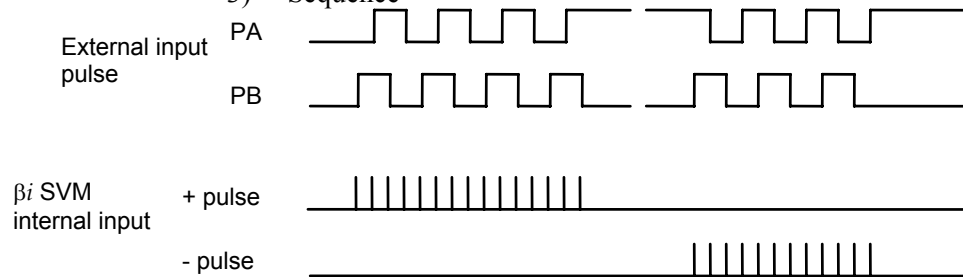

- Recommended circuit example

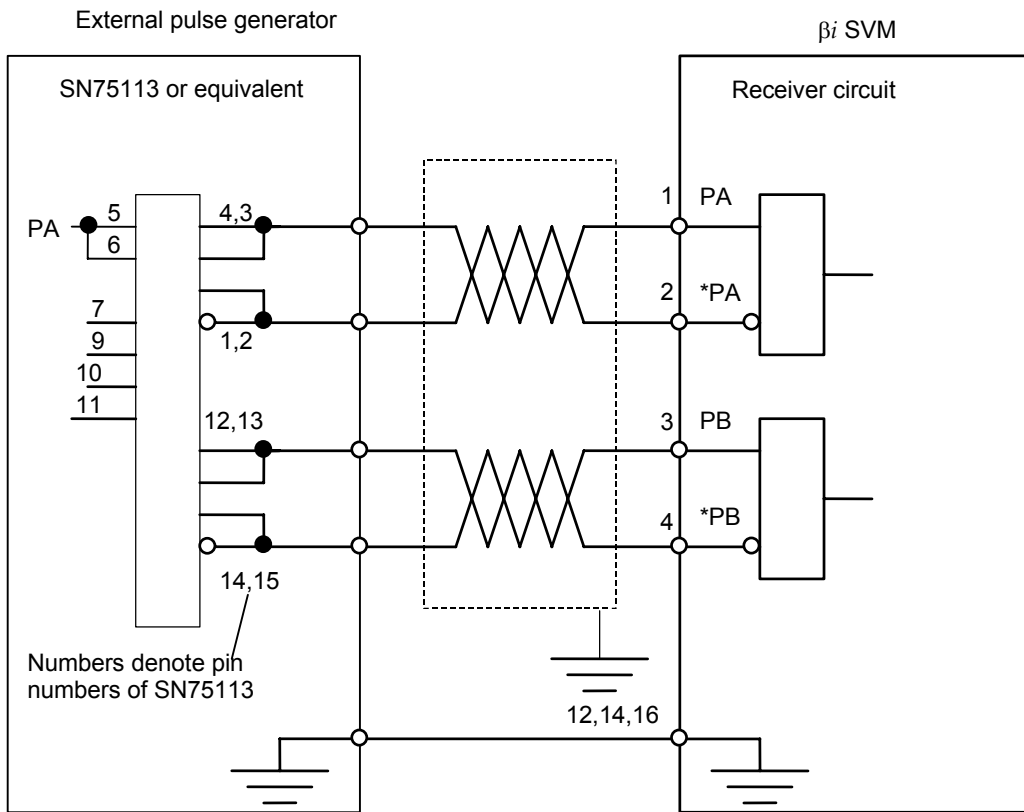

9.2.17 Connection to Servo Check Board

The servo check board converts digital values used for control in the digital servo system into analog voltages to allow observation with instruments such as an oscilloscope.

Ordering specification

A cable with a reverse connection prevention feature and a servo check board adapter are required to connect the servo check board to the β_i SVM.

Ordering specification	Name
A06B-6057-H630	Servo check board
A06B-6050-K871	Cable with reverse connection prevention feature
A06B-6093-K021	Servo check board adapter (adapter board and cable, both dedicated to β_i SVM)

Connection

Before installing and removing the servo check board, turn off the power to the β_i SVM.

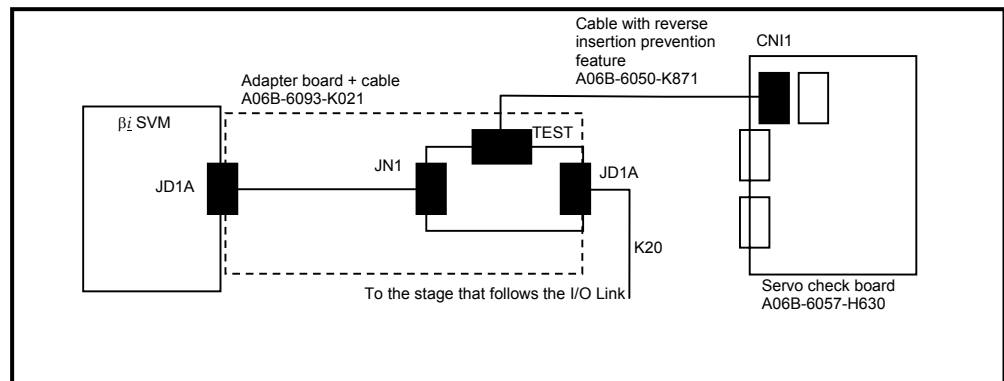

NOTE

The servo check board adapter and the servo check board may be connected only when adjustments are made. Never start operation while they are left connected.

10 HEAT DISSIPATION

See Chapter 10 “HEAT DISSIPATION” in Part I.

APPENDIX

A

CONNECTING THE REACTOR AND LINE FILETER

A.1 OVERVIEW

Below are an correct example and incorrect examples of connection of the reactor for the power supply regenerative amplifier and the line filter for the resistive discharge amplifier.

A.2 CONNECTION EXAMPLES

Correct connection

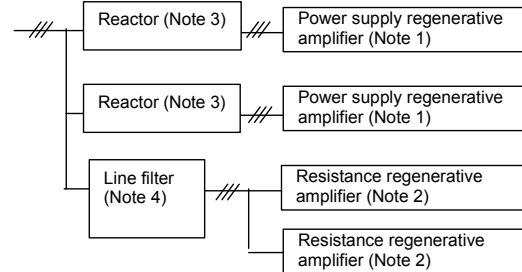

- One power supply regenerative amplifier is connected to one reactor.
- The line filter is connected from the primary side of the reactor.
- More than one resistance regenerative amplifier can be connected to the line filter. (The current rating of the line filter must not be exceeded, however.)

Incorrect connection (1)

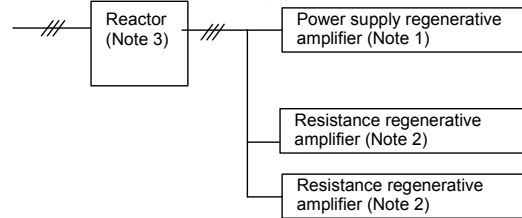

- The resistance regenerative amplifier is connected to the secondary side of the reactor. The resistance regenerative amplifier may be damaged. The power supply regenerative amplifier may malfunction.

Incorrect connection (2)

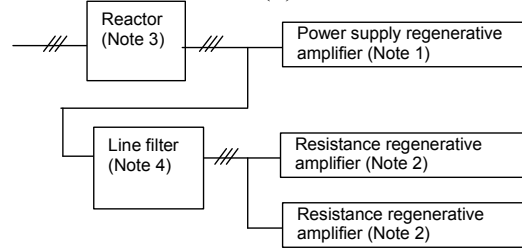

- The line filter is connected from the secondary side of the reactor. The resistance regenerative amplifier may be damaged. The power supply regenerative amplifier may malfunction.

Incorrect connection (3)

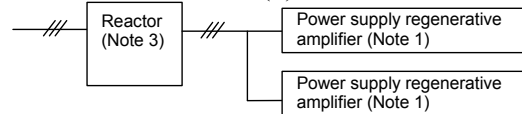

- More than one power supply regenerative amplifier is connected to one reactor. One power supply regenerative amplifier may be damaged. The other power supply regenerative amplifier may malfunction.

NOTE
 Any devices must not be connected between the reactor and power supply regenerative amplifier. Otherwise, the connected device may be damaged and the power supply regenerative amplifier may malfunction.

- (1) Power supply regenerative amplifier
- | | |
|-----------------------|--------------------------------|
| α series PSM | A06B-6077-HXXX, A06B-6087-HXXX |
| αi series PSM | A06B-6110-HXXX |
| βi series SVPM | A06B-6134-HXXX |
| Others | |
- (2) Resistance regenerative amplifier
- | | |
|------------------------|----------------|
| α series PSMR | A06B-6081-HXXX |
| αi series PSMR | A06B-6115-HXXX |
| α series SVU | A06B-6089-HXXX |
| α series SVUC | A06B-6090-HXXX |
| β series SVU | A06B-6093-HXXX |
| βi series SVM | A06B-6130-HXXX |
| | A06B-6132-HXXX |
| Others | |
- (3) Reactor
- A81L-0001-0133
 - A81L-0001-0147
 - A81L-0001-0150
 - A81L-0001-0122
 - A81L-0001-0123
 - A81L-0001-0120
 - A81L-0001-0124
 - A81L-0001-0155
 - A81L-0001-0156
 - A81L-0001-0157
 - A81L-0001-0158
 - A81L-0001-0159
 - A81L-0001-0160
 - Others
- (4) Line filter
- A81L-0001-0083/3C
 - A81L-0001-0101/C
 - A81L-0001-0102
 - Others

INDEX

<Symbol>

*+OT, *-OT, and *RILK(*DEC)..... 227

<A>

AC Line Filter 10, 53, 204

APPLICABLE MOTORS 8, 191

Battery Case 55

Battery Case (for Size D Alkaline Battery)..... 204

<C>

Cable Clamp and Shield Processing..... 36

CONFIGURATION 4, 186

CONNECTING THE REACTOR AND LINE

FILETER 243

CONNECTION DIAGRAM 66, 207

CONNECTION EXAMPLES 245

Connection of external magnetic contactor when β i

SVM FSSB interface is used together..... 221

Connection of FANUC I/O Link by electric cable..... 224

Connection of FANUC I/O Link by optical fiber cable 225

Connection to External Pulse Generator 229

Connection to Servo Check Board 238

Connection Tools 72, 217

Connection when differential type A/B phase pulse

generator is used 230

Connection when FANUC's manual pulse generator is

used..... 231

CONNECTOR LOCATION 70, 215

Control Power 196

COOLING FAM MOTORS..... 11, 192

<D>

DERATING 12, 193

Details of Cable K1 73, 217

Details of Cable K10..... 94, 222

Details of Cable K11 96, 222

Details of Cable K2 77, 219

Details of Cable K20

(Connection of FANUC I/O Link)..... 223

Details of Cable K21 (Internal DI Connection)..... 226

Details of Cable K3 82, 219

Details of Cable K6..... 89, 219

Details of Cable K7 90, 220

Details of Cable K8 91, 222

Details of Cable K9 93, 222

Details of cables (general)..... 83

Details of Cables K4 and K5 85, 219

Details of connectors..... 77, 82

Details of input cables 81

Discharge Resistor..... 50, 60

<E>

ENVIRONMENTAL CONDITIONS 31

EXTERNAL DIMENSIONS 46, 202

EXTERNAL DIMENSIONS / PANEL CUT-OUT

DRAWINGS / MAINTENANCE AREA 45, 201

External Dimensions of Fan Unit (A06B-6134-K002).... 49

External Dimensions of Fan Unit (A06B-6134-K003).... 48

External Dimensions of SVM1-40i and SVM1-80i 47

External Dimensions of SVM1-4i and SVM1-20i 46

<F>

Fan Unit (A06B-6134-K002) 204

<G>

Grounding 34, 198

<H>

HANDLING OF EXTERNAL MAGNETIC

CONTACTORS 97

HEAT DISSIPATION..... 98, 239

How to Select a Transformer..... 29

<I>

INPUT POWER SUPPLY 24, 196

INSTALLATION CONDITIONS AND NOTES ... 30, 197

Installing a Separate Cooling Fan motor 11

INSTALLING LIGHTNING SURGE ABSORBERS ... 39

Installing the Cooling Fan Motor in the SVM1-4i and

SVM1-20i 192

<L>

Lightning Surge Absorbers 56, 204

<M>

MAINTENANCE AREA 62, 205

Maintenance Area for the SVM1-40i 205

Maintenance Area for the SVM1-40i and SVM1-80i 63

Maintenance Area for the SVM1-4i and SVM1-20i	
.....	62, 205
Maintenance Area for the SVM1-80i	205
Models Requiring Cooling Fan motors	11
<N>	
NOISE PROTECTION	33
Noise Suppressor	35
<O>	
ORDERING INFORMATION	22m 194
<P>	
PANEL CUT-OUT DRAWINGS	58, 204
Power cable for servo motor	84
POWER SUPPLY	23, 195
POWER TRANSFORMER FOR EXPORTS	28, 196
PROTECTIVE GROUNDING	42
<S>	
SAFETY PRECAUTIONS	s-1
SELECTING A GROUND-FAULT CIRCUIT	
INTERRUPTER	32
Selecting AC Line Filter	191
Selecting cables (general)	80
Selecting Circuit Breaker	9, 191
SELECTING CIRCUIT BREAKER, MAGNETIC	
CONTACTOR, AND AC LINE FILTER	9, 191
Selecting Magnetic Contactor	10, 191
SEPARATED REGENERATIVE DISCHARGE	
RESISTOR	13, 193
Separated Regenerative Discharge Resistor	204
Separation of Signal Lines	33
Sequence for turning on control power supply	196
Servo motor αi , αis series, Servo motor βis series	
($\beta 0.4/5000is$ to $\beta 22/2000is$)	73, 217
Servo motor βis series ($\beta 0.2/5000is$, $\beta 0.3/5000is$)	75, 218
Signals	226
Single-phase Input for Control Power	24
Single-phase Input Power Supply for Motor Power	
.....	24, 196
Skip signal interface	228
Specification	7, 8, 28, 189, 190
SVM1-40i and SVM1-80i	
.....	6, 59, 68, 71, 87, 188, 200, 203, 209, 213, 216
SVM1-40i and SVM1-80i (FSSB Interface)	44
SVM1-4i and SVM1-20i	
.....	5, 58, 66, 70, 85, 187, 199, 202, 207, 211, 215
SVM1-4i and SVM1-20i (FSSB Interface)	43
SVM1-80i	192
<T>	
Three-phase Input Power Supply for Motor Power	24, 196
TOTAL CONNECTION DIAGRAM	65, 206
Transformer for Exports	55, 204
<W>	
When a Separated Regenerative Discharge Resistor Is	
Needed	15
When Amplifier Models SVM-40i and SVM-80i Are Used	
.....	17
When No Separated Regenerative Discharge Resistor Is	
Needed	13

Revision Record

FANUC SERVO AMPLIFIER β i series DESCRIPTIONS (B-65322EN)

02	Aug., 2004	Total revision							
01	Aug., 2003	_____							
Edition	Date	Contents	Edition	Date	Contents				

FANUC SERVO AMPLIFIER βi series DESCRIPTIONS

1. Type of applied documents

Name	FANUC SERVO AMPLIFIER βi series DESCRIPTIONS
Spec. No./Ver.	B-65322EN/02-02

2. Summary of Change

Group	Name / Outline	New, Add Correct, Del	Applicable Date
Basic Function			
Optional Function			
Unit			
Maintenance Parts			
Notice			
Correction			
Another	Addition of $\beta(HV)i$ series SVM	New	2005. 1

				TITLE	FANUC SERVO AMPLIFIER βi series DESCRIPTIONS			
				DRAW. No.	B-65322EN/02-02			
01	05.01.18	K.Inaba	Add newly	FANUC LTD			Page	1 / 17
EDIT	DATE	DESIGN	DESCRIPTION					

1. Configuration

AC400V input type

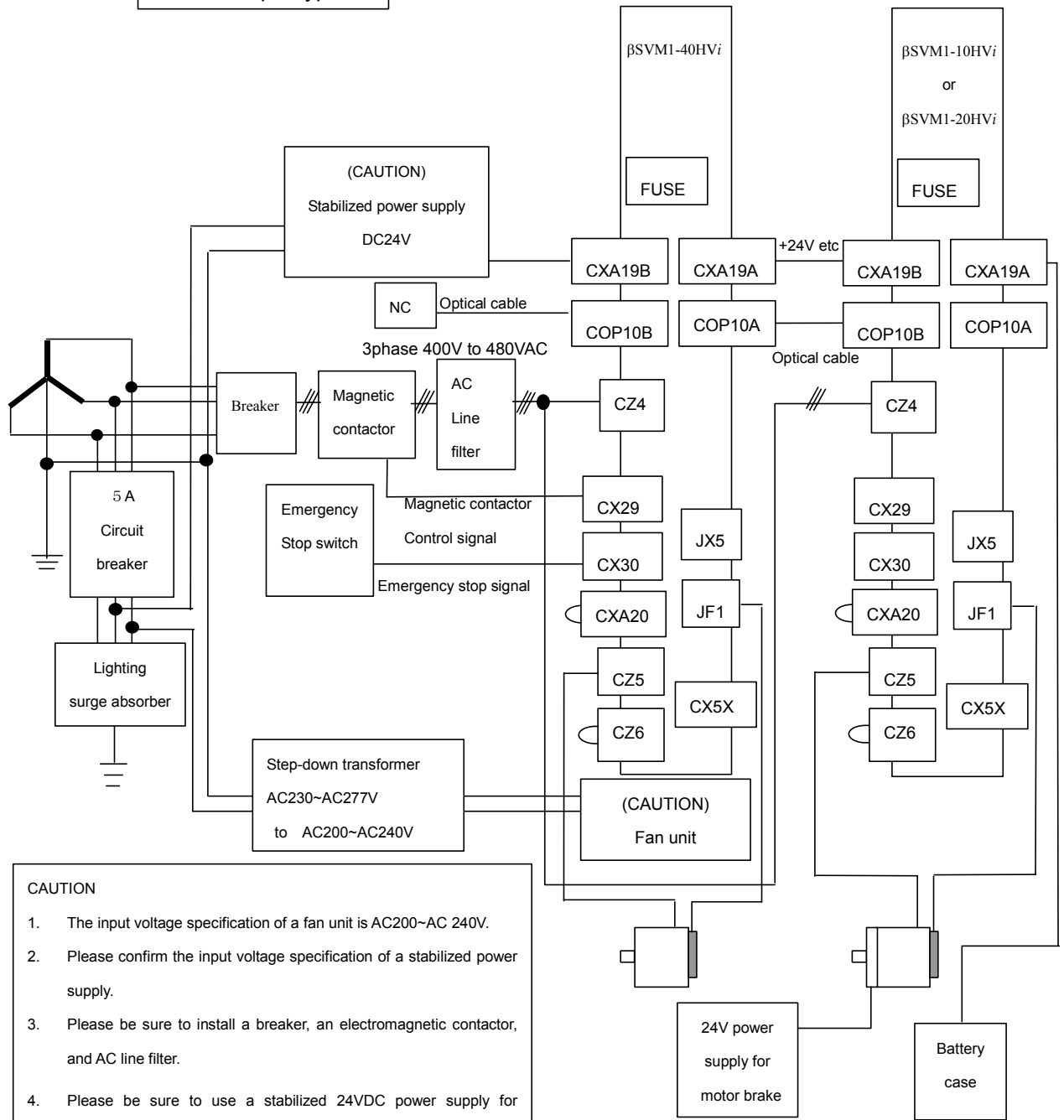

CAUTION

1. The input voltage specification of a fan unit is AC200~AC 240V.
2. Please confirm the input voltage specification of a stabilized power supply.
3. Please be sure to install a breaker, an electromagnetic contactor, and AC line filter.
4. Please be sure to use a stabilized 24VDC power supply for amplifier. Common use with 24V power supply for motor brakes cannot be performed.
5. The cabling of CX29 and CX30 of the second and subsequent amplifiers may be omitted. Refer to "Total connection diagram" for details.

				TITLE	FANUC SERVO AMPLIFIER <i>βi</i> series DESCRIPTIONS		
				DRAW. No.	B-65322EN/02-02		
EDIT	DATE	DESIGN	DESCRIPTION	FANUC LTD			Page 3 / 17

2. Specification

Item	SVM 1-10HV _i	SVM 1-20HV _i	SVM 1-40HV _i
Interface	FSSB		
Unit Designation	A06B-6131-H001	A06B-6131-H002	A06B-6131-H003
Power P.C.B.	A16B-3200-0515	A16B-3200-0516	A16B-3200-0517
Control P.C.B.	A20B-2101-0051		
Main Power For Three Phase Supply	Input Voltage	AC 400-480 V (+10%, -15%) 50 / 60 Hz	
	Current at 50Hz	2.3 A _{rms}	3.6 A _{rms} 9.0A _{rms}
	Rated Capacity	1.6 kVA	2.5 kVA 6.2kVA
Control Power supply	Input Voltage	DC 24 V (+10%, -10%)	
	Input Current	0.9 A _{rms}	
Rated Output Current	3.1A _{rms}	5.6A _{rms}	9.2A _{rms}
Current Limit Value	10Ap	20 Ap	40 Ap
Servo HRV control	HRV2, HRV3		
Main Circuit Control Method	Sine Wave PWM Control with Transistor Bridges		
Dynamic brake circuit	Built-in		
Servo output frequency range	0-334Hz		
Warning and protective functions	<ul style="list-style-type: none"> - High Current - PM Abnormal - High Voltage of DC Link - Low Voltage of DC Link - Overheat of Discharge Resistor - Low Voltage of Control Power Supply - FSSB Communication Error - Locked Fan Motor 		
Ambient Temperature Range	0 to +55 degrees Celsius		
Weight	3.9kg		
Option	Built-in regenerative resistor (64ohm, 50W no-wind condition) (64ohm, 130W wind velocity 2m/s condition) Separated AC line filter Separated battery		

				TITLE	FANUC SERVO AMPLIFIER β _i series DESCRIPTIONS
				DRAW. No.	B-65322EN/02-02
EDIT	DATE	DESIGN	DESCRIPTION	FANUC LTD	Page 4 / 17

3. Applicable motors

MOTOR	α_i	2		4		8		12		22	
				α_4 / 4000HVi (20A)		α_8 / 3000HVi (20A)		α_{12} / 3000HVi (40A)		α_{22} / 3000HVi (40A)	
		α_{2s}	α_2 / 5000HVi s (10A)	α_4 / 5000HVi s (10A)			α_8 / 4000HVi s (40A)		α_{12} / 4000HVi s (40A)		
		β_{is}	β_2 / 4000HVi s (10A)	β_4 / 4000HVi s (10A)		β_8 / 3000HVi s (10A)		β_{12} / 3000HVi s (20A)		β_{22} / 2000HVi s (20A)	
SVM1-	10HVi	○	○		○						
	20HVi			○		○		○		○	
	40HVi						○		○		○

				TITLE	FANUC SERVO AMPLIFIER β_i series DESCRIPTIONS		
				DRAW. No.	B-65322EN/02-02		
EDIT	DATE	DESIGN	DESCRIPTION	FANUC LTD			Page 5 / 17

4. Selection of breaker, electromagnetic contactor, and AC line filter

4.1. Breaker

Name	Specification	Note
The breaker for main power supplies (30A)	A06B-6077-K101	Fuji Electric EA53B/30+ cover BZ-TB20B-3
The breaker for control sources (5A)	A06B-6077-K106	Fuji Electric EA33/5+ cover BZ-TB10B-503

4.2. Electromagnetic contactor

Name	Specification	Note
Electromagnetic contactor (32A)	A06B-6077-K121	Fuji Electric SC-5-1+ cover SZ-JC4

4.3. AC line filter

Name	Specification	Note
AC line filter	A81L-0001-0168	
AC line filter	A81L-0001-0169	

Please refer to the following table and select it. For details, please refer to B-65322/02JA.

Servo motor	Continuous rating current [Arms] (Reference value)	Power supply capacity [kVA] (Reference value)
β 2/4000HV i s	1.2	0.8
β 4/4000HV i s	1.7	1.2
β 8/3000HV i s	2.7	1.9
β 12/3000HV i s	4.0	2.8
β 22/2000HV i s	5.6	3.9
α 2/5000HV i s	1.7	1.2
α 4/5000HV i s	2.3	1.6
α 4/4000HV i	3.2	2.2
α 8/3000HV i	3.6	2.5
α 8/4000HV i s	5.2	3.6
α 12/4000HV i s	5.6	3.9
α 12/3000HV i	6.7	4.7
α 22/3000HV i	9.0	6.2

				TITLE	FANUC SERVO AMPLIFIER β i series DESCRIPTIONS		
				DRAW. No.	B-65322EN/02-02		
EDIT	DATE	DESIGN	DESCRIPTION	FANUC LTD			Page 6 / 17

5. Cooling fan motor

The fan motor for amplifier cooling is needed for the following model.

Ordering number	Amplifier	Applied motor
A06B-6134-K002	SVM1-40HV <i>i</i>	All motors

6. Derating

Consider derating as shown below, according to ambient temperature.

The solid line is a derating line for use when HRV2, while the dotted line is a derating line for use when HRV3 is applied.

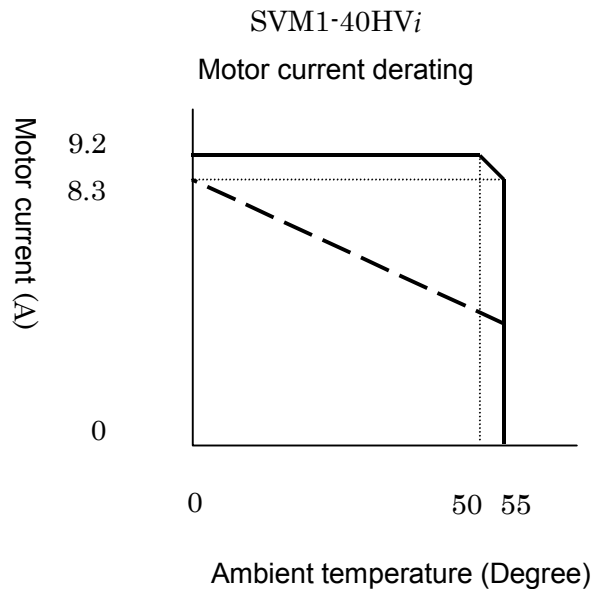
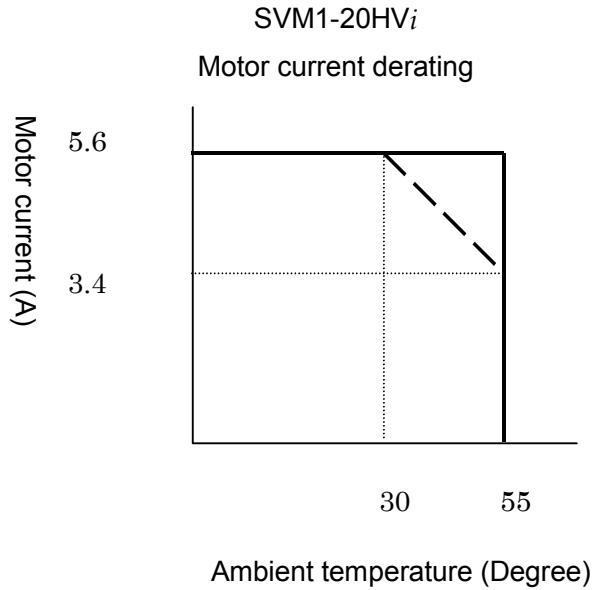

				TITLE	FANUC SERVO AMPLIFIER <i>βi</i> series DESCRIPTIONS		
				DRAW. No.	B-65322EN/02-02		
EDIT	DATE	DESIGN	DESCRIPTION	FANUC LTD			Page 7 / 17

7. Capacity of regeneration discharge resistor

The regeneration discharge resistor of the following capacity is built in the servo amplifier module.

Amplifier	Specification	Capacity of regeneration discharge resistance
SVM1-10HV <i>i</i>	A06B-613 1 -H001	50W
SVM1-20HV <i>i</i>	A06B-613 1 -H002	No –wind condition
SVM1-40HV <i>i</i>	A06B-613 1 -H003	130W Wind velocity 2m/s condition

8. Setup switch (For DC alarm level)

Since the switch of four channels is in the front of a servo amplifier module for regeneration resistance protection, please make it the following setup.

Switch	Setup
Switch1	OFF
Switch2	OFF
Switch3	ON
Switch4	ON

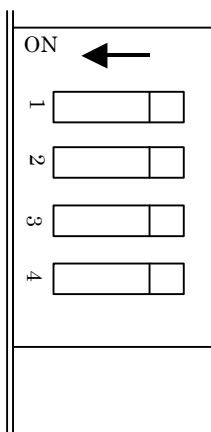

				TITLE	FANUC SERVO AMPLIFIER <i>βi</i> series DESCRIPTIONS		
				DRAW. No.	B-65322EN/02-02		
EDIT	DATE	DESIGN	DESCRIPTION	FANUC LTD			Page 8 / 17

9. Power supply specification

9.1. Three-phase input power supply for motor power

- Nominal rating voltage: 400V to 480VAC
Star connection, neutral grounding
PE is provided on the power line

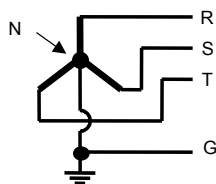

- Allowable voltage fluctuation: -15% - +10%
- Frequency: 50/60Hz
- Allowable frequency fluctuation: ± 2 Hz
- Power supply impedance : Voltage fluctuation by load (at maximum output) not be exceed 7%.
- Power supply Unbalance: $\pm 5\%$ or less of rated voltage

9.2. Single-phase input for control power

Please be sure to use a regulated power supply for 24V power supply for amplifier.
Common use with 24V power supply for motor brakes cannot be performed.

- Nominal rating voltage: 24VDC
- Allowable voltage fluctuation: $\pm 10\%$ (Including momentary variations)
- Power supply capacity

	Power supply capacity per amplifier
FSSB interface	0.9A

				TITLE	FANUC SERVO AMPLIFIER βi series DESCRIPTIONS		
				DRAW. No.	B-65322EN/02-02		
EDIT	DATE	DESIGN	DESCRIPTION	FANUC LTD			Page 9 / 17

10. Installing of lighting surge absorber

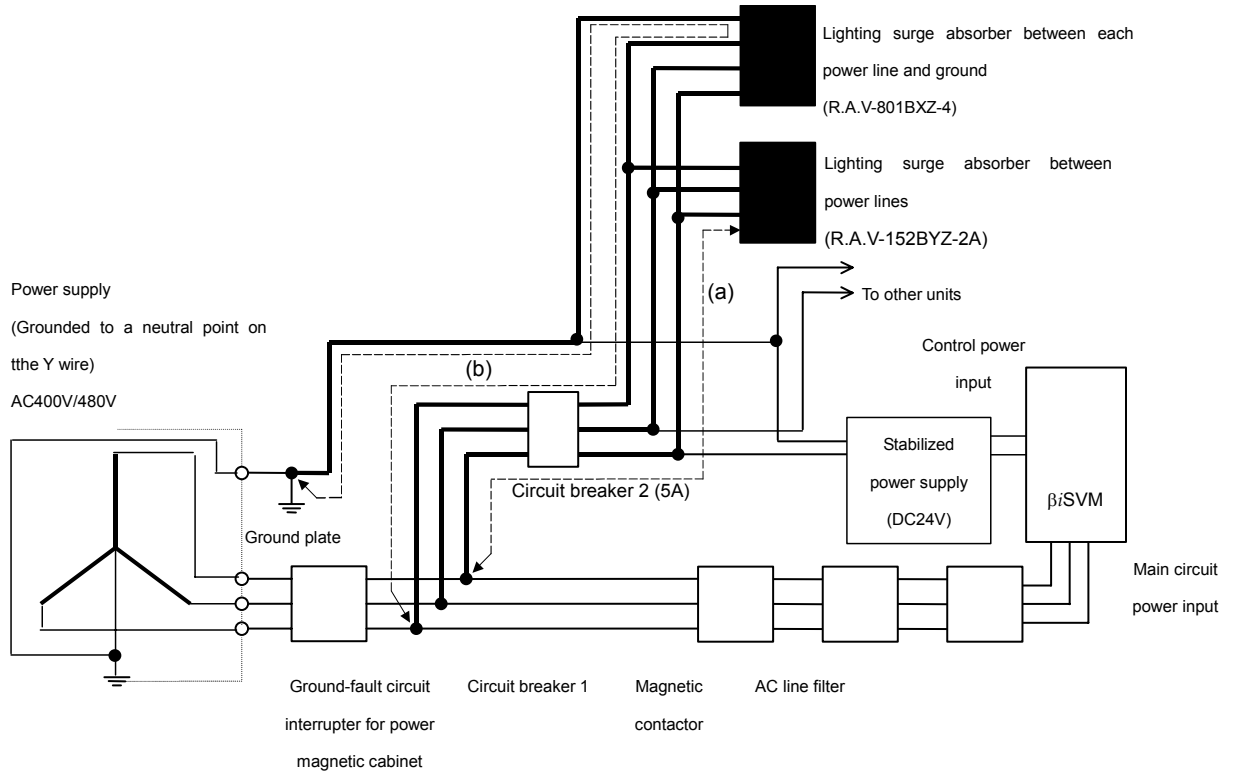

CAUTIONS

- (1) To increase the efficiency of lightning surge absorption, the wires indicated by bold lines should be as short as possible.
 Wire cross-sectional area : 2 mm² or more
 Wire length :
 The total length of the cables used for line-to-line lightning surge protector (a) and that used for line-to-ground lightning surge protector (b) must not exceed 2 m.
- (2) When performing a dielectric strength test by applying an overvoltage to the power line, line-to-ground lightning surge protector must be removed to enable the applied voltage to be maintained.
- (3) The circuit breaker 2 (5A) works for line protection when the lightning surge absorber is short-circuited because of a surge higher than its rating being applied.
- (4) Because current does not flow through lightning surge protector in a normal state, the circuit breaker 2 (5A) can be used together with the surge absorbers as well as with other equipment.

				TITLE	FANUC SERVO AMPLIFIER β i series DESCRIPTIONS		
				DRAW. No.	B-65322EN/02-02		
EDIT	DATE	DESIGN	DESCRIPTION	FANUC LTD			Page 10 / 17

11. External dimension/ Panel cut-out drawing/ maintenance area

11.1. SVM1-10HV*i*, SVM1-20HV*i*, SVM1-40HV*i*

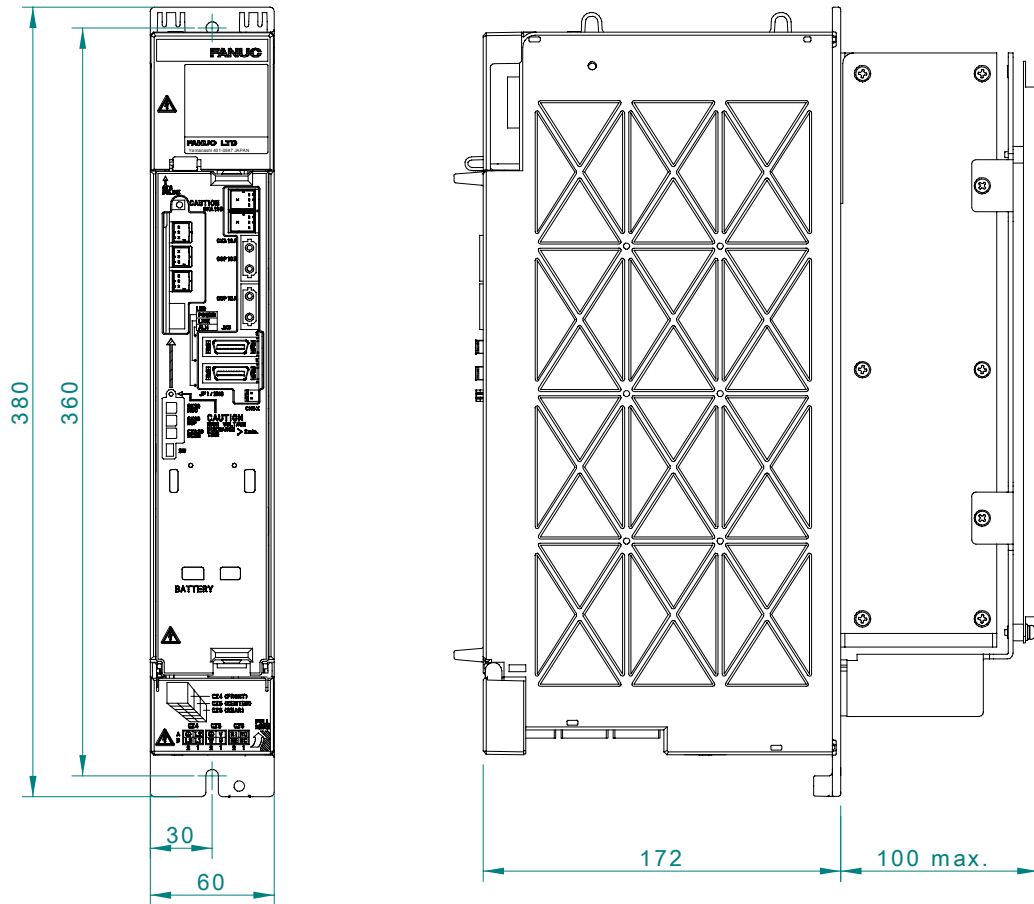

External dimensions/ panel cut-out/ maintenance area is the same as SVM1-40*i* and SVM1-80*i*. Please refer to B-65322/02EN for details.

				TITLE	FANUC SERVO AMPLIFIER <i>βi</i> series DESCRIPTIONS	
				DRAW. No.	B-65322EN/02-02	
EDIT	DATE	DESIGN	DESCRIPTION	FANUC LTD		Page 11 / 17

11.2. AC line filter
 11.2.1 A81L-0001-0168

NOTE
 The outer diagram and dimension may be changed without announcement.

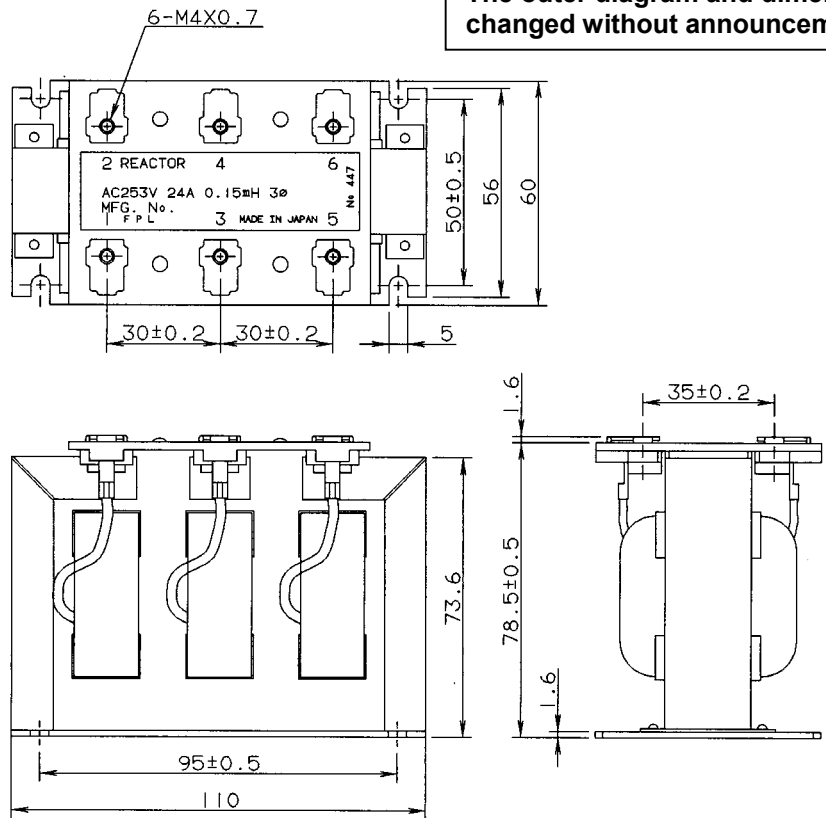

11.2.2 A81L-0001-0169

NOTE
 The outer diagram and dimension may be changed without announcement.

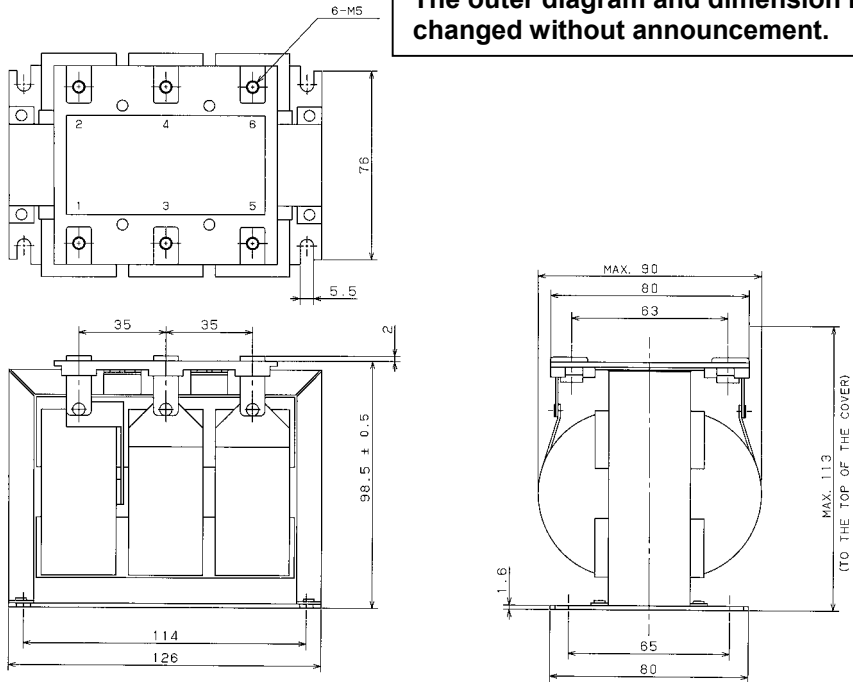

				TITLE	FANUC SERVO AMPLIFIER βi series DESCRIPTIONS	
				DRAW. No.	B-65322EN/02-02	
EDIT	DATE	DESIGN	DESCRIPTION	FANUC LTD		Page 12 / 17

11.3. Lighting surge absorber A06B-6077-K143

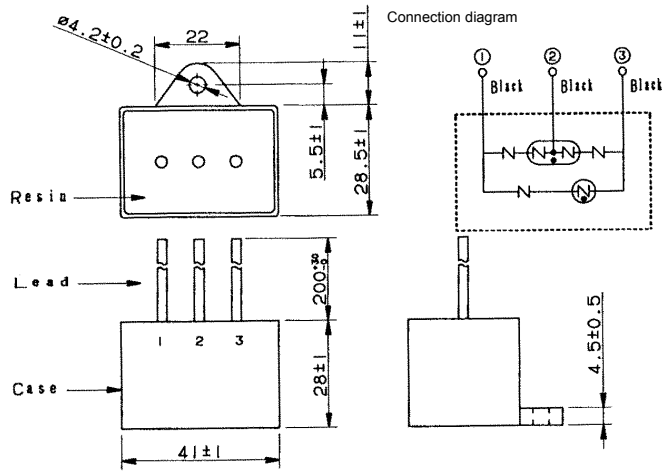

(1) For line-to-line installation: RAV-152BYZ-2A

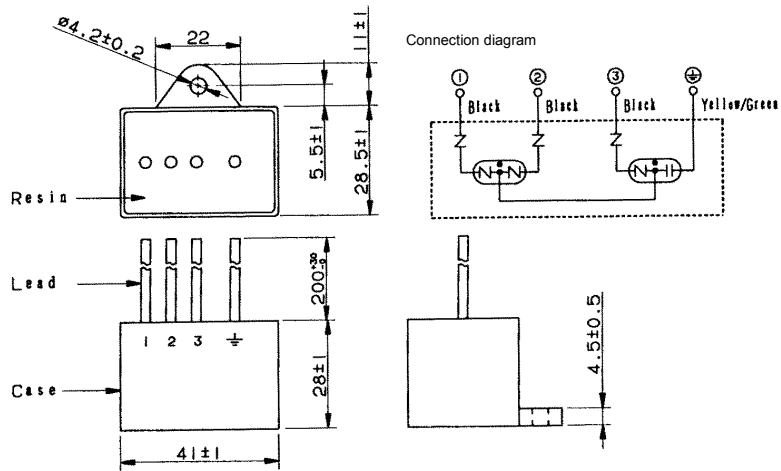

(2) For line-to-ground installation: RAV-801BXZ-4

Specification	Rated voltage	Clamp voltage	Surge withstand current	Surge withstand voltage
R-A-V-152BYZ-2A	460VAC	1470V $\pm 10\%$ (V1.0)	2500A(8/20 μ S)	20kV(1.2/50 μ S)

Specification	Rated voltage	AC discharge start voltage	Surge withstand current	Maximum surge discharge start voltage
R-A-V-801BXZ-4	line-to-line: 500VAC, line-to-ground: 290VAC	800VAC $\pm 20\%$ (Ua)	2500A(8/20 μ S)	2.32kV(1.2/50 μ S)

				TITLE	FANUC SERVO AMPLIFIER β i series DESCRIPTIONS	
				DRAW. No.	B-65322EN/02-02	
EDIT	DATE	DESIGN	DESCRIPTION	FANUC LTD		Page 13 / 17

12.1. Connection details

Refer to Section [I. .SVM] of B-65322EN/02 for details.

12.1.1. Details of cable K2 (Refer to B-65322/02EN)

Please select specification of cables in consideration of following table. Refer to Section [I. .SVM] of B-65322EN/02 for details.

Servo motor	Continuous rating current [Arms] (Reference value)
β 2/4000HV i s	1.2
β 4/4000HV i s	1.7
β 8/3000HV i s	2.7
β 12/3000HV i s	4.0
β 22/2000HV i s	5.6
α 2/5000HV i s	1.7
α 4/5000HV i s	2.3
α 4/4000HV i	3.2
α 8/3000HV i	3.6
α 8/4000HV i s	5.2
α 12/4000HV i s	5.6
α 12/3000HV i	6.7
α 22/3000HV i	9.0

				TITLE	FANUC SERVO AMPLIFIER β i series DESCRIPTIONS		
				DRAW. No.	B-65322EN/02-02		
EDIT	DATE	DESIGN	DESCRIPTION	FANUC LTD			Page 15 / 17

12.1.2. Details of cable K3 (Refer to B-65322/02EN)

Please select specification of cables in consideration of following table. Refer to Section [I. .SVM] of B-65322EN/02 for details.

Servo motor	Continuous rating current [Arms] (Reference value)
β 2/4000HV i s	1.7
β 4/4000HV i s	2.4
β 8/3000HV i s	3.1
β 12/3000HV i s	5.1
β 22/2000HV i s	5.7
α 2/5000HV i s	1.7
α 4/5000HV i s	3.1
α 4/4000HV i	4.1
α 8/3000HV i	4.2
α 8/4000HV i s	5.6
α 12/4000HV i s	6.7
α 12/3000HV i	9.1
α 22/3000HV i	9.2

				TITLE	FANUC SERVO AMPLIFIER β i series DESCRIPTIONS		
				DRAW. No.	B-65322EN/02-02		
EDIT	DATE	DESIGN	DESCRIPTION	FANUC LTD			Page 16 / 17

13. Heat dissipation

The amount of heat dissipation depends on the SVM model and the current that flows through the servo motor. For the current that flows through a servo motor, reference the continuous rated current of each servo motor. (For the continuous rated current of each servo motor, refer to the servo motor descriptions.) As the current that flows through a servo motor, the root-mean-square value of the current that flows through an actual servo motor on a machine can be used. The amount of heat dissipation indicated below assumes the use of HRV2.

(1) Total amount of heat dissipation

The total amount of heat dissipation is calculated according to the following expression:

$$\text{Total amount of heat dissipation} = a + K a_1 \times b_1$$

a: Amount of heat dissipation determined by the SVM model [W]

Ka1: Coefficient determined by the SVM [W/Arms]

b1: Current flowing through the servo motor [Arms]

Total amount of heat dissipation

Name	Specification	a [W]	K [W/Arms]
SVM1-10HV <i>i</i>	H001	20	Ka1: 10.8
SVM1-20HV <i>i</i>	H002	20	Ka1: 11.1
SVM1-40HV <i>i</i>	H003	20	Ka1: 11.1

(2) Residual amount of heat in the cabinet

By placing the heat sink section outside the cabinet, the residual amount of heat in the cabinet can be calculated according to the expression below.

$$\text{Residual amount of heat in the cabinet} = a + K b_1 \times b_1$$

a: Amount of heat dissipation determined by the SVM model [W]

Kb1: Coefficient determined by the SVM [W/Arms]

b1: Current flowing through the servo motor [Arms]

Residual amount of heat in the cabinet

Name	Specification	a [W]	K [W/Arms]
SVM1-10HV <i>i</i>	H001	20	Ka1: 2.2
SVM1-20HV <i>i</i>	H002	20	Ka1: 2.2
SVM1-40HV <i>i</i>	H003	20	Ka1: 1.1

				TITLE	FANUC SERVO AMPLIFIER <i>β</i> <i>i</i> series DESCRIPTIONS		
				DRAW. No.	B-65322EN/02-02		
EDIT	DATE	DESIGN	DESCRIPTION	FANUC LTD			Page 17 / 17

FANUC SERVO AMPLIFIER β iSV 20/20 DESCRIPTIONS

1. Type of applied documents

Name	FANUC SERVO AMPLIFIER β iSV 20/20 DESCRIPTIONS
Spec. No./Ver.	B-65322EN/02-03

2. Summary of Change

Group	Name / Outline	New, Add Correct, Del	Applicable Date
Basic Function			
Optional Function			
Unit			
Maintenance Parts			
Notice			
Correction			
Another	Addition of β iSV 20/20	New	2005. 7

				TITLE	FANUC SERVO AMPLIFIER β iSV 20/20 DESCRIPTIONS			
				DRAW. No.	B-65322EN/02-03			
01	05.07.21	K.Inaba	Add newly	FANUC LTD				
EDIT	DATE	DESIGN	DESCRIPTION			Page	1 / 23	

βiSV 20/20 DESCRIPTIONS

This documents describes about the specification of βiSV 20/20.

Please refer to FANUC SERVO AMPLIFIER βi series DESCRIPTIONS (B-65322EN/02) about contents without in this.

(Note)

This Servo amplifier βiSV 20/20 is available to use combining Series 0i-MODEL C/
0i Mate-MODEL C.

All specifications and designs are subject to change without notice.

				TITLE	FANUC SERVO AMPLIFIER βiSV 20/20 DESCRIPTIONS		
				DRAW. No.	B-65322EN/02-03		
EDIT	DATE	DESIGN	DESCRIPTION	FANUC LTD		Page	2 / 23

1. Configuration

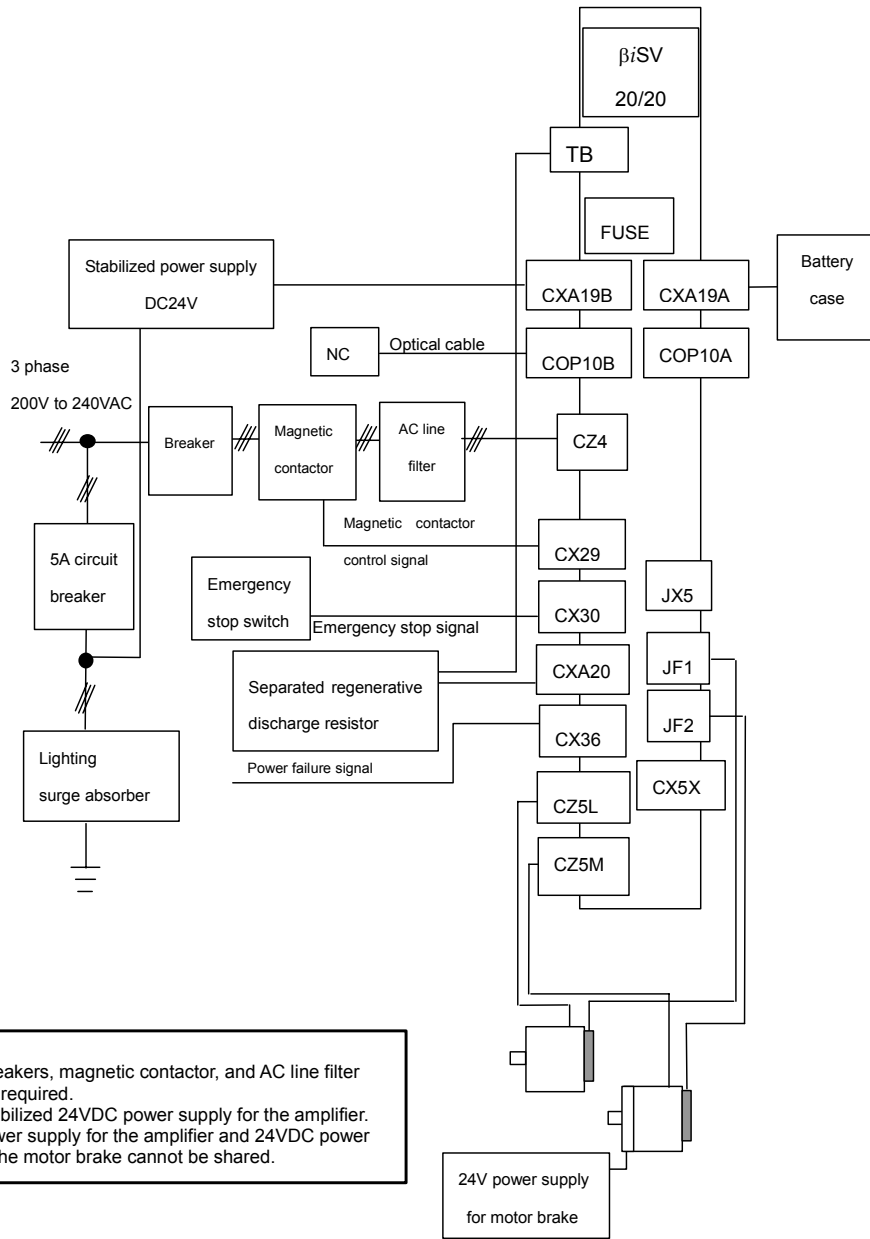

CAUTION

- 1 A circuit breakers, magnetic contactor, and AC line filter are always required.
- 2 Use the stabilized 24VDC power supply for the amplifier. 24VDC power supply for the amplifier and 24VDC power supply for the motor brake cannot be shared.

				TITLE	FANUC SERVO AMPLIFIER β iSV 20/20 DESCRIPTIONS		
				DRAW. No.	B-65322EN/02-03		
EDIT	DATE	DESIGN	DESCRIPTION	FANUC LTD			Page 3 / 23

2. Specification

Item		βi SV 20/20	
Interface		FSSB	
Unit Designation		A06B-6136-H201	
Power P.C.B.		A16B-3200-0642	
Control P.C.B.		A20B-2101-0290	
Main Power For Three Phase Supply	Input Voltage	AC 200-240 V (+10%,-15%)	50 / 60 Hz
	Current at 50Hz	7.6Arms	
	Rated Capacity	2.7kVA	
Control Power supply	Input Voltage	DC 24 V (+10%, -10%)	
	Input Current	0.8 Arms	
Rated Output Current	L-Axis	6.5Arms	
	M-Axis	6.5Arms	
Current Limit Value	L-Axis	20 Ap	
	M-Axis	20 Ap	
Servo control		HRV2, HRV3	
Main Circuit Control Method		Sine Wave PWM Control with Transistor Bridges	
Servo output frequency range		0-667Hz	
Warning and protectivefunctions		<ul style="list-style-type: none"> - High Current - IPM Abnormal - High Voltage of DC Link - Low Voltage of DC Link - Overheat of Discharge Resistor - Low Voltage of Control Power Supply - FSSB Communication Error - Locked Fan Motor 	
Ambient Temperature Range		0 to +55 degrees Celsius	
Weight		3.9kg	
Option		Regeerative resistor (16ohm, 100W no-wind condition) (16ohm, 200W no-wind condition) (16ohm, 400W wind velocity 2m/s condition) Separated AC line filter Separated battery	

				TITLE	FANUC SERVO AMPLIFIER βi SV 20/20 DESCRIPTIONS		
				DRAW. No.	B-65322EN/02-03		
EDIT	DATE	DESIGN	DESCRIPTION	FANUC LTD			Page 4 / 23

3. Applicable motors

		0.4	0.5	1	2	4	8	12
MOTOR	$\alpha i F$			$\alpha i F1$ / 5000 (20A)	$\alpha i F2$ / 5000 (20A)			
	$\alpha i S$				$\alpha i S2$ / 5000 / 6000 (20A)	$\alpha i S4$ / 5000 (20A)		
	$\beta i s$	$\beta i S0.4$ /5000 (20A)	$\beta i S0.5$ /6000 (20A)	$\beta i S1$ /6000 (20A)	$\beta i S2$ /4000 (20A)	$\beta i S4$ /4000 (20A)	$\beta i S8$ /3000 (20A)	$\beta i S12$ /2000 (20A)
SV 20/20	L axis	O	O	O	O	O	O	O
	axis	O	O	O	O	O	O	O

				TITLE	FANUC SERVO AMPLIFIER βiSV 20/20 DESCRIPTIONS				
				DRAW. No.	B-65322EN/02-03				
EDIT	DATE	DESIGN	DESCRIPTION	FANUC LTD				Page	5 / 23

4. Selection of breaker, electromagnetic contactor, and AC line filter

Please refer to the following table and select it. For details, please refer to B-65322/02EN.

Servo motor	Continuous rating current [Arms] (Reference value)	Power supply capacity [kVA] (Reference value)
βiS 0.4/5000	0.6	0.2
βiS 0.5/6000	1.4	0.47
βiS 1/6000	2.3	0.77
βiS 2/4000	2.2	0.77
βiS 4/4000	3.3	1.2
βiS 8/3000	5.4	1.9
βiS 12/2000	6.3	2.2
αiF 1/5000	2.2	0.77
αiF 2/5000	3.3	1.2
αiS 2/5000	3.3	1.2
αiS 2/6000	4.5	1.6
αiS 4/5000	4.5	1.5

5. Derating

Consider derating as shown below, according to ambient temperature.

The solid line is a derating line for use when HRV2, while the dotted line is a derating line for use when HRV3 is applied.

				TITLE	FANUC SERVO AMPLIFIER βiS V 20/20 DESCRIPTIONS		
				DRAW. No.	B-65322EN/02-03		
EDIT	DATE	DESIGN	DESCRIPTION	FANUC LTD			Page 6 / 23

Motor current derating

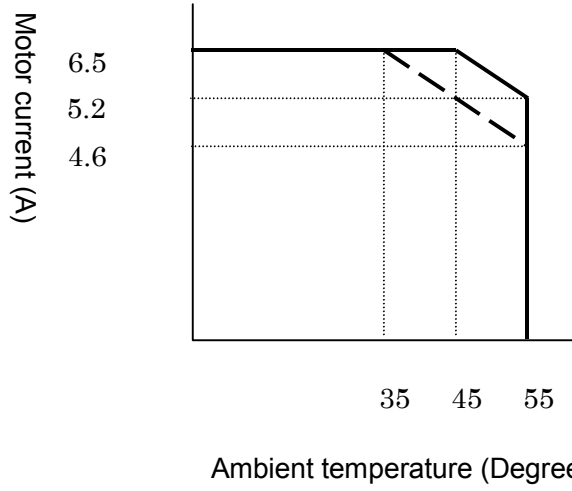

				TITLE	FANUC SERVO AMPLIFIER β iSV 20/20 DESCRIPTIONS		
				DRAW. No.	B-65322EN/02-03		
EDIT	DATE	DESIGN	DESCRIPTION	FANUC LTD		Page	7 / 23

6. Regeneration discharge resistor

6.1. When separated regenerative discharge resistor is not needed.

When the regeneration energy per regenerative cycle is below the following amounts of energy [J], regeneration discharge resistor is unnecessary.

Table6.1 Permissible regenerative energy amount (Reference value)

Amplifier model	Permissible regenerative energy amount
βi SV 20/20	25[J]

Refer to Section [I. SVM] of B-65322EN/02 for details about calculation method of the regeneration energy per regenerative cycle.

6.2. When separated regenerative discharge resistor is needed.

When the regeneration energy per regenerative cycle exceeds the amount of permission regenerative energy of servo amplifier, DC link overvoltage alarm or abnormal of regeneration discharge may occur. In this case, regenerative discharge resistor is needed.

Table6.2 Capacity of regenerative discharge resistor

Specification	Capacity of regenerative discharge resistor	
	A06B-6130-H404 (Note1) (Note2)	100W No –wind condition
A06B-6089-H500 (Note1)	200W No –wind condition	400W Wind velocity 2m/s condition

⚠ Cautions

- Please install into the cabinet, which fulfills the following conditions so that cutting fluid, oil mist, cutting waste, etc. may not adhere to regeneration discharge resistor.
So, please install in the environment of the pollution degree 2 level specified to "IEC 60664-1."

In order to satisfy a pollution degree 2 under the severe environment of a machine tool, it is necessary to install in a cabinet with which it is generally satisfied of IP54.

If the cabinet does not have a structure for preventing materials that adversely affect regenerative discharge resistor from getting into the cabinet, normal operation and safety may fail. So, special care should be taken.

- Incorrect connection may cause to damage the amplifier.

				TITLE	FANUC SERVO AMPLIFIER βi SV 20/20 DESCRIPTIONS		
				DRAW. No.	B-65322EN/02-03		
EDIT	DATE	DESIGN	DESCRIPTION	FANUC LTD			Page 8 / 23

7. Setup switch (For DC alarm level)

Since the switch of four channels is in the front of a servo amplifier for regeneration resistance protection, please make it the following setup.

Setup of SW1, SW2

Switch	Setup
Switch1	OFF
Switch2	OFF

Setup of SW3, SW4

SW3	SW4	Separated regenerative discharge resistor
ON	ON	A06B-6130-H404 (Note1)
OFF	ON	A06B-6089-H500

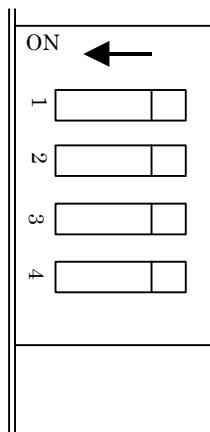

				TITLE	FANUC SERVO AMPLIFIER β iSV 20/20 DESCRIPTIONS		
				DRAW. No.	B-65322EN/02-03		
EDIT	DATE	DESIGN	DESCRIPTION	FANUC LTD			Page 9 / 23

8. Power supply specification

8.1. Three-phase input power supply for motor power

- Nominal rating voltage: 200V to 240VAC
- Allowable voltage fluctuation: -15% - +10%
- Frequency: 50/60Hz
- Allowable frequency fluctuation: ± 2 Hz
- Power supply impedance : Voltage fluctuation by load (at maximum output) not be exceed 7%.
- Power supply Unbalance: $\pm 5\%$ or less of rated voltage

NOTE

The allowable voltage fluctuation is a change observed for several minutes. It is not a continuous change.

8.2. Single-phase input for control power

Please be sure to use a regulated power supply for 24V power supply for amplifier.
Common use with 24V power supply for motor brakes cannot be performed.

- Nominal rating voltage: 24VDC
- Allowable voltage fluctuation: $\pm 10\%$ (Including momentary variations)
- Power supply capacity

	Power supply capacity per amplifier
FSSB interface	0.8A

				TITLE	FANUC SERVO AMPLIFIER β iSV 20/20 DESCRIPTIONS		
				DRAW. No.	B-65322EN/02-03		
EDIT	DATE	DESIGN	DESCRIPTION	FANUC LTD			Page 10 / 23

9. External dimension/ Panel cut-out drawing/ maintenance area

9.1. External dimension

β iSV 20/20

Without outer fin

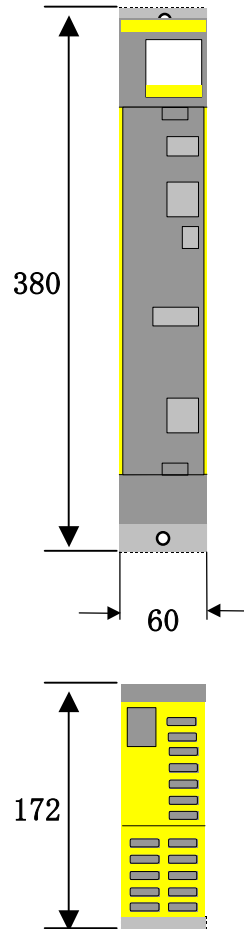

				TITLE	FANUC SERVO AMPLIFIER β iSV 20/20 DESCRIPTIONS		
				DRAW. No.	B-65322EN/02-03		
EDIT	DATE	DESIGN	DESCRIPTION	FANUC LTD			Page 11 / 23

External dimension Regenerative discharge resistor (A06B-6130-H404)

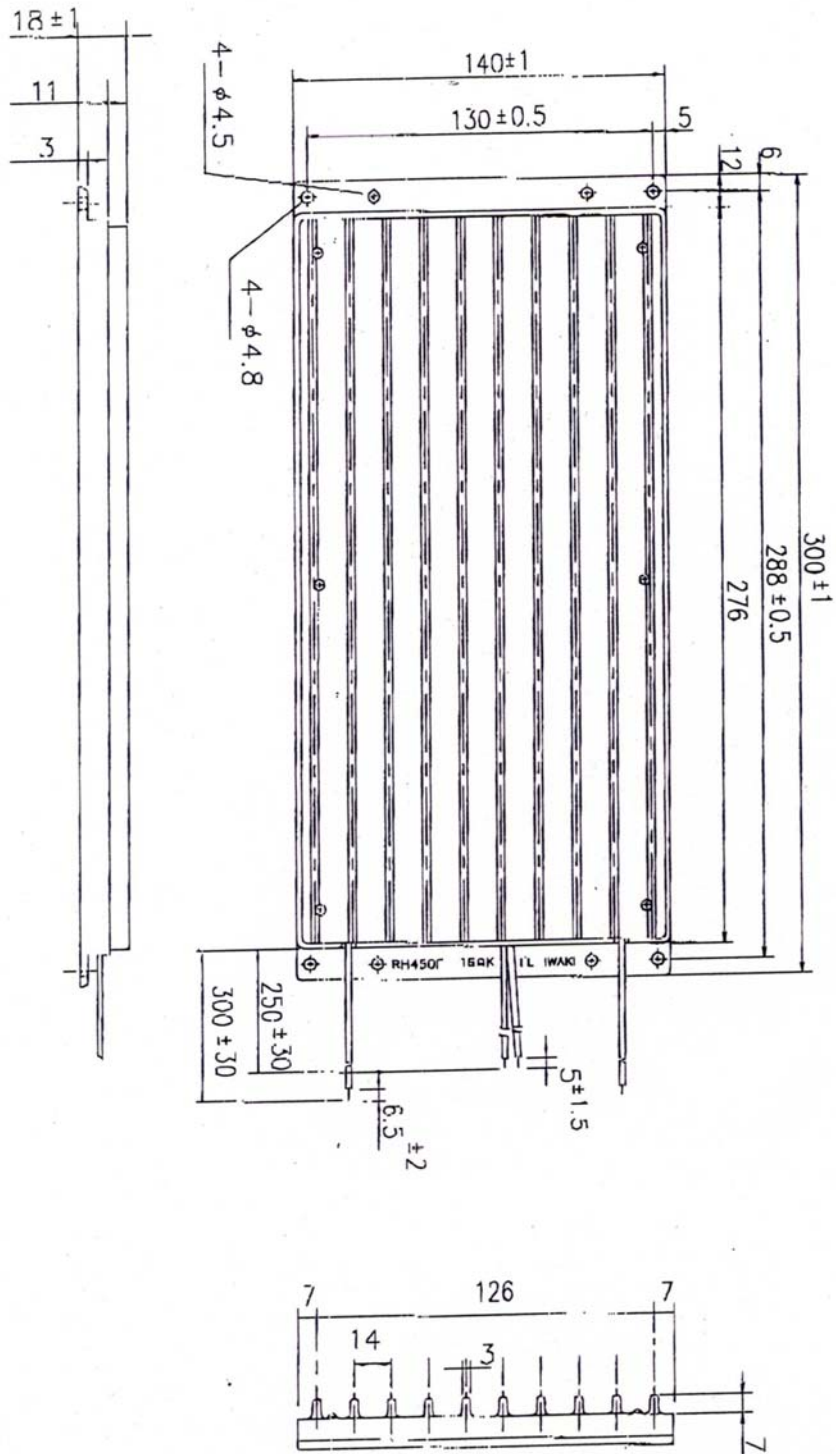

				TITLE	FANUC SERVO AMPLIFIER β iSV 20/20 DESCRIPTIONS	
				DRAW. No.	B-65322EN/02-03	
EDIT	DATE	DESIGN	DESCRIPTION	FANUC LTD		Page 12 / 23

9.2. Panel cut-out drawing

β iSV 20/20

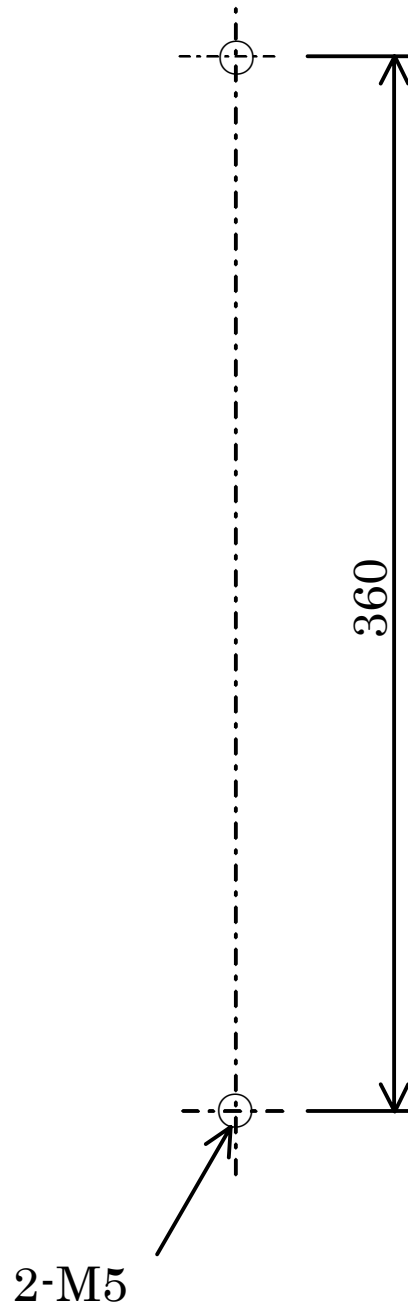

				TITLE	FANUC SERVO AMPLIFIER β iSV 20/20 DESCRIPTIONS		
				DRAW. No.	B-65322EN/02-03		
EDIT	DATE	DESIGN	DESCRIPTION	FANUC LTD		Page	13 / 23

9.3. Maintenance area

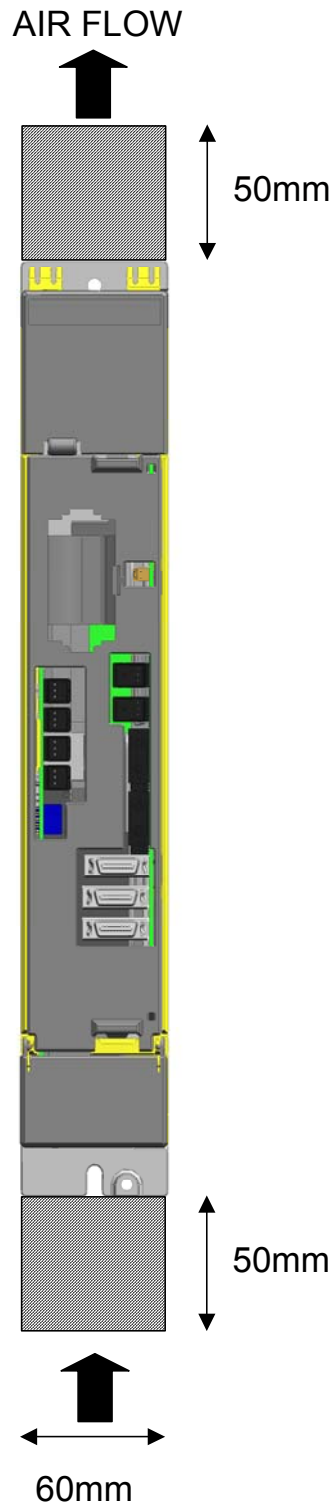

				TITLE	FANUC SERVO AMPLIFIER <i>β</i> iSV 20/20 DESCRIPTIONS		
				DRAW. No.	B-65322EN/02-03		
EDIT	DATE	DESIGN	DESCRIPTION	FANUC LTD		Page	14 / 23

10. Power failure detecting function

The power failure detect function aiming at the gravity axis fall prevention at the time of a power failure was occurred.
Please refer to the section [11.5] for connection details.

In case of using this function, please add an uninterruptible power supply (UPS) etc. to be able to maintain the control source (DC 24V) of CNC and amplifier after a power failure occurs until mechanical brake operates.

Specification

2-axes amplifier βiSV output a power failure detect signal from a connector CX36, when power failure is occurred.

The drop of three-phase circuit AC voltage inputted into the connector “CZ4” of 2-axes amplifier βiSV is detected.

CZ4 input voltage range: 0 V-AC240V+10% 3 ϕ 50Hz/60Hz \pm 2Hz

CZ4 power failure detect voltage: AC165V \pm 10V

Detection delay time is established so that it may not react sensitively to instantaneous power failure.

Detection delay time: 8msec~17msec

(Note)

The detect condition is simultaneous three-phase circuit AC voltage drop.
Therefore, it may be unable to detect a power failure correctly on following conditions.

1. Power failure (phase interruption) as only one phase drop.
2. Power failure occurred at the time of motor acceleration. (Please see below.)

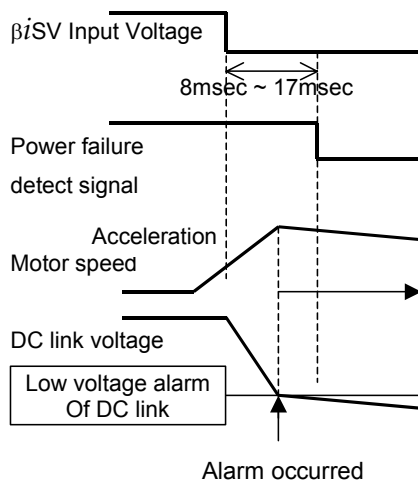

A power failure detecting signal is outputted from βiSV behind time 8msec~17msec after power failure occur. When the output power of motor is large by acceleration, DC link voltage falls rapidly. So, even if power failure is detected, DC link low voltage alarm may be occurred.

3. The amplifier is necessary to operate normally at instantaneous power failure for 3msec or less and for this terms the power failure detect signal is not detected.

				TITLE	FANUC SERVO AMPLIFIER βiSV 20/20 DESCRIPTIONS		
				DRAW. No.	B-65322EN/02-03		
EDIT	DATE	DESIGN	DESCRIPTION	FANUC LTD			Page 15 / 23

11. Total connection diagram

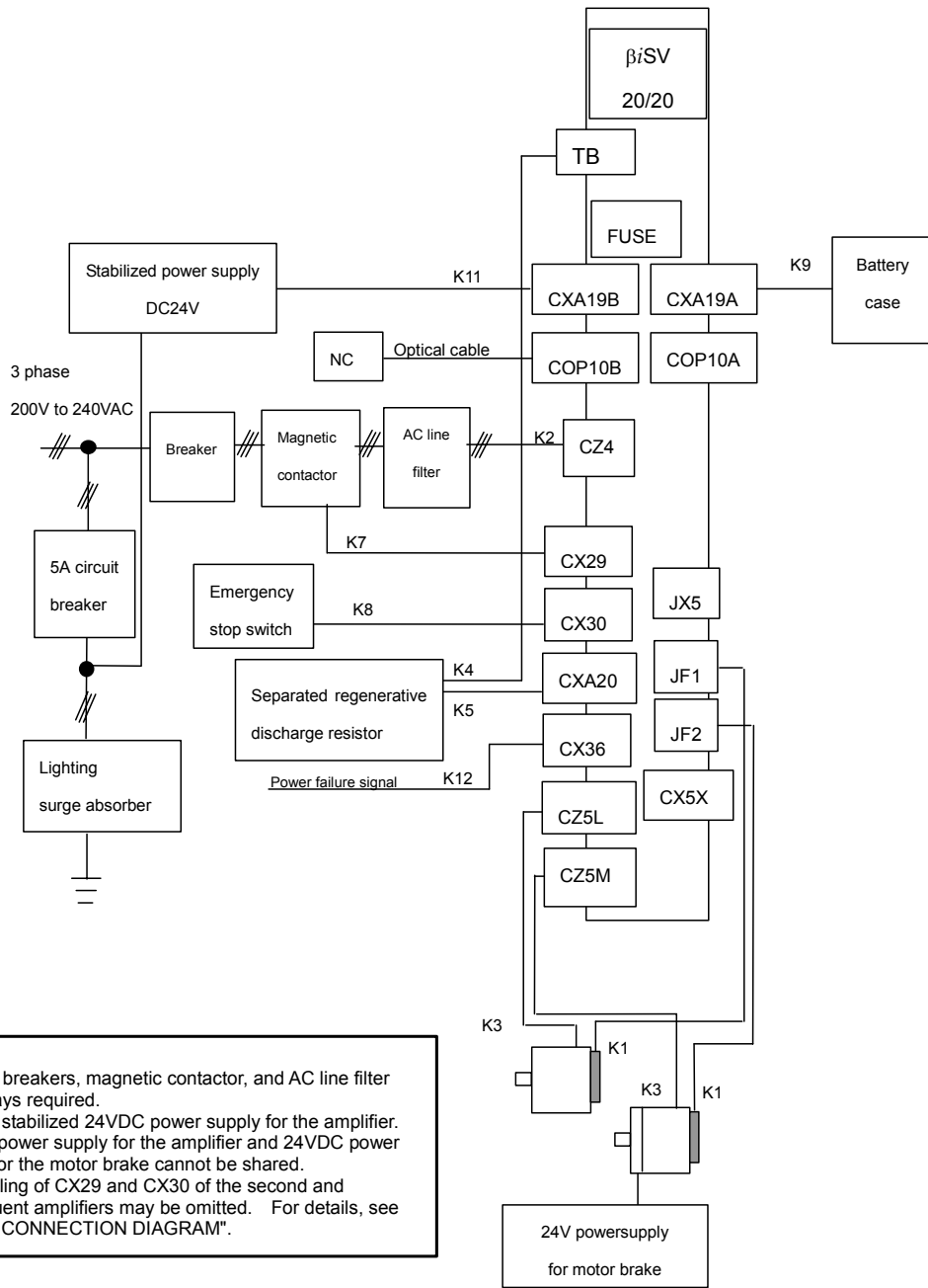

CAUTION

- 1 A circuit breakers, magnetic contactor, and AC line filter are always required.
- 2 Use the stabilized 24VDC power supply for the amplifier. 24VDC power supply for the amplifier and 24VDC power supply for the motor brake cannot be shared.
- 3 The cabling of CX29 and CX30 of the second and subsequent amplifiers may be omitted. For details, see "TOTAL CONNECTION DIAGRAM".

				TITLE	FANUC SERVO AMPLIFIER βiSV 20/20 DESCRIPTIONS		
				DRAW. No.	B-65322EN/02-03		
EDIT	DATE	DESIGN	DESCRIPTION	FANUC LTD			Page 16 / 23

11.1. Connection details

Refer to Section [I. .SVM] of B-65322EN/02 for details.

11.2. Details of cable K2 (Refer to B-65322/02EN)

Please select specification of cables in consideration of following table. Refer to Section [I .SVM] of B-65322EN/02 for details.

Servo motor	Continuous rating current [Arms] (Reference value)
βiS 0.4/5000	0.6
βiS 0.5/6000	1.4
βiS 1/6000	2.3
βiS 2/4000	2.2
βiS 4/4000	3.3
βiS 8/3000	5.4
βiS 12/2000	6.3
αiF 1/5000	2.2
αiF 2/5000	3.3
αiS 2/5000	3.3
αiS 2/6000	4.5
αiS 4/5000	4.5

				TITLE	FANUC SERVO AMPLIFIER βiSV 20/20 DESCRIPTIONS		
				DRAW. No.	B-65322EN/02-03		
EDIT	DATE	DESIGN	DESCRIPTION	FANUC LTD			Page 17 / 23

11.3. Details of cable K3 (Refer to B-65322/02EN)

Please select specification of cables in consideration of following table. Refer to Section [I.SVM] of B-65322EN/02 for details.

Servo motor	Continuous rating current [Arms] (Reference value)
βiS 0.4/5000	3.6
βiS 0.5/6000	3.0
βiS 1/6000	2.7
βiS 2/4000	3.2
βiS 4/4000	4.7
βiS 8/3000	6.0
βiS 12/2000	6.5
αiF 1/5000	2.7
αiF 2/5000	3.5
αiS 2/5000	3.3
αiS 2/6000	4.1
αiS 4/5000	4.6

				TITLE	FANUC SERVO AMPLIFIER βiSV 20/20 DESCRIPTIONS		
				DRAW. No.	B-65322EN/02-03		
EDIT	DATE	DESIGN	DESCRIPTION	FANUC LTD			Page 18 / 23

11.4. Details of cable K4 (Refer to B-65322/02EN)
 In case of using regenerative discharge resistor
 (a) A06B-6130-H404

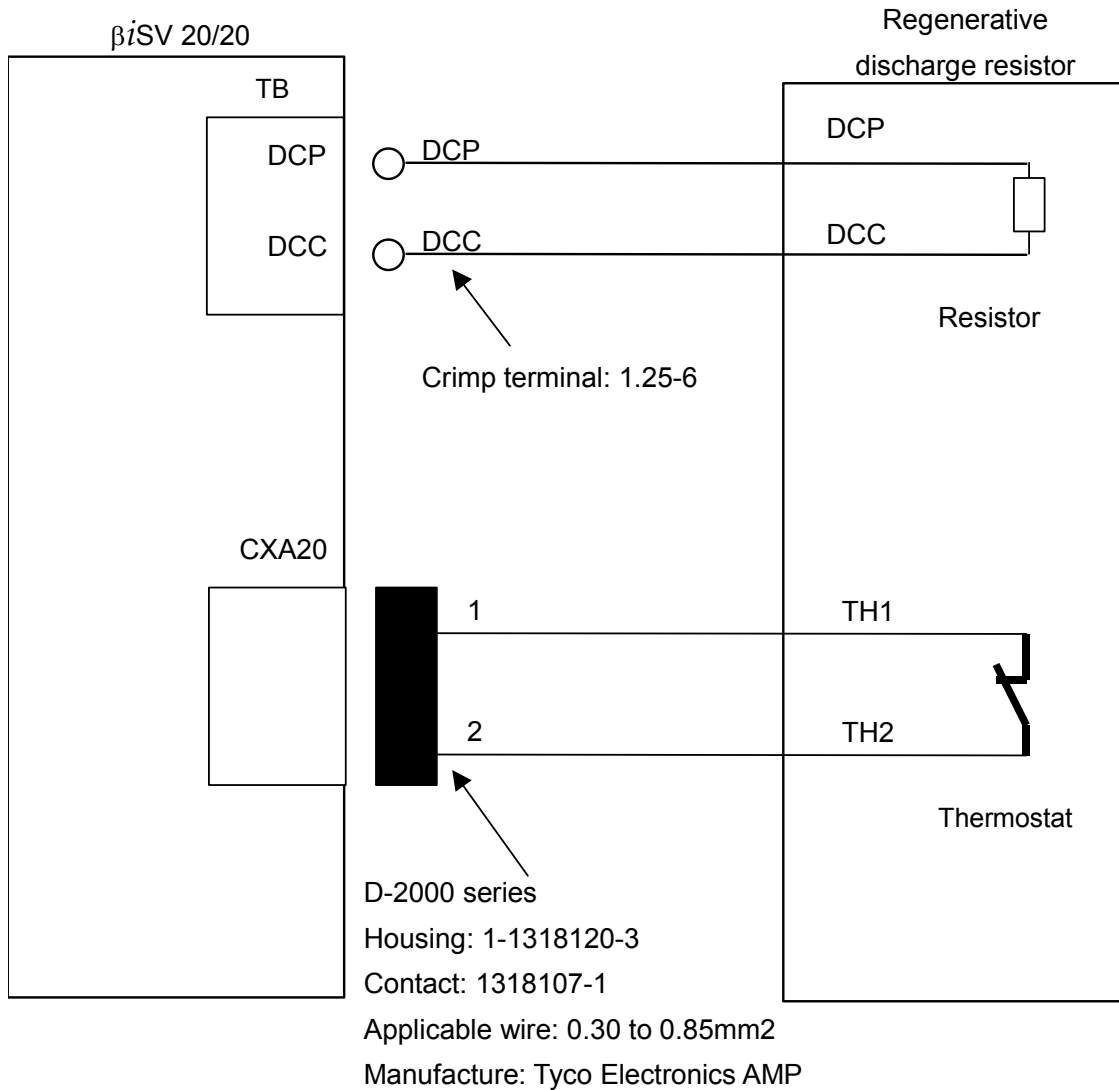

For connection tools, see subsection 9.2.3. of [I.SVM] for B-65322EN/02

⚠ WARNING

- Do not short between terminal “DCP” and terminal “DCC”.
- Do not connect this terminal “TB” to terminal “TB1(DCP/DCN)” of servo amplifier *αi* series.

Servo amplifier may be broken in case of above incorrect connection.

				TITLE	FANUC SERVO AMPLIFIER βiSV 20/20 DESCRIPTIONS		
				DRAW. No.	B-65322EN/02-03		
EDIT	DATE	DESIGN	DESCRIPTION	FANUC LTD			Page 19 / 23

(b) A06B-6089-H500

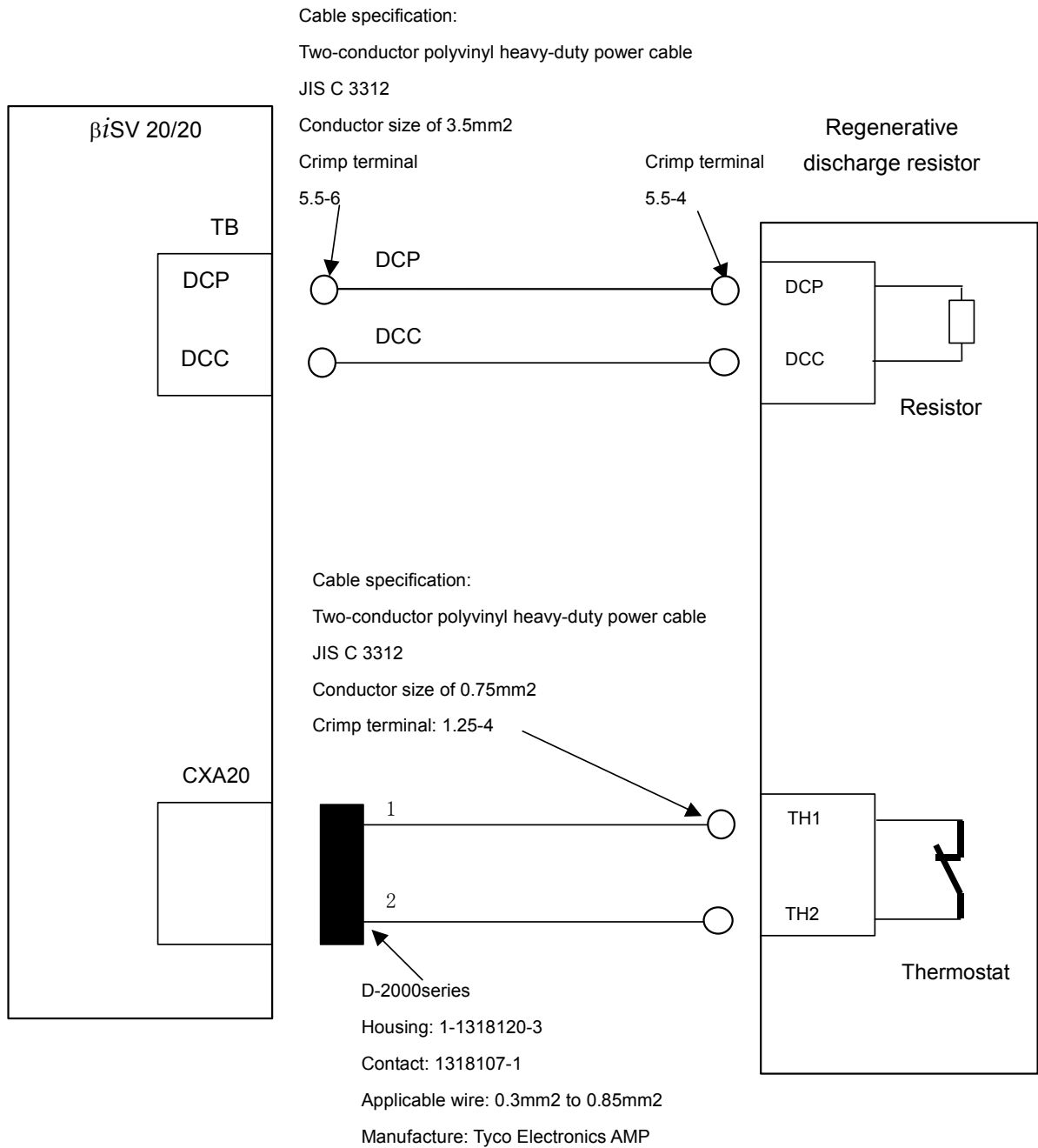

For connection tools, see subsection 9.2.3. of [I.SVM] for B-65322EN/02

⚠ WARNING

- Do not short between terminal “DCP” and terminal “DCC”.
- Do not connect this terminal “TB” to terminal “TB1(DCP/DCN)” of servo amplifier αi series.

Servo amplifier may be broken in case of above incorrect connection.

				TITLE	FANUC SERVO AMPLIFIER βiSV 20/20 DESCRIPTIONS		
				DRAW. No.	B-65322EN/02-03		
EDIT	DATE	DESIGN	DESCRIPTION	FANUC LTD		Page	20 / 23

(c) In case of not using regenerative discharge resistor

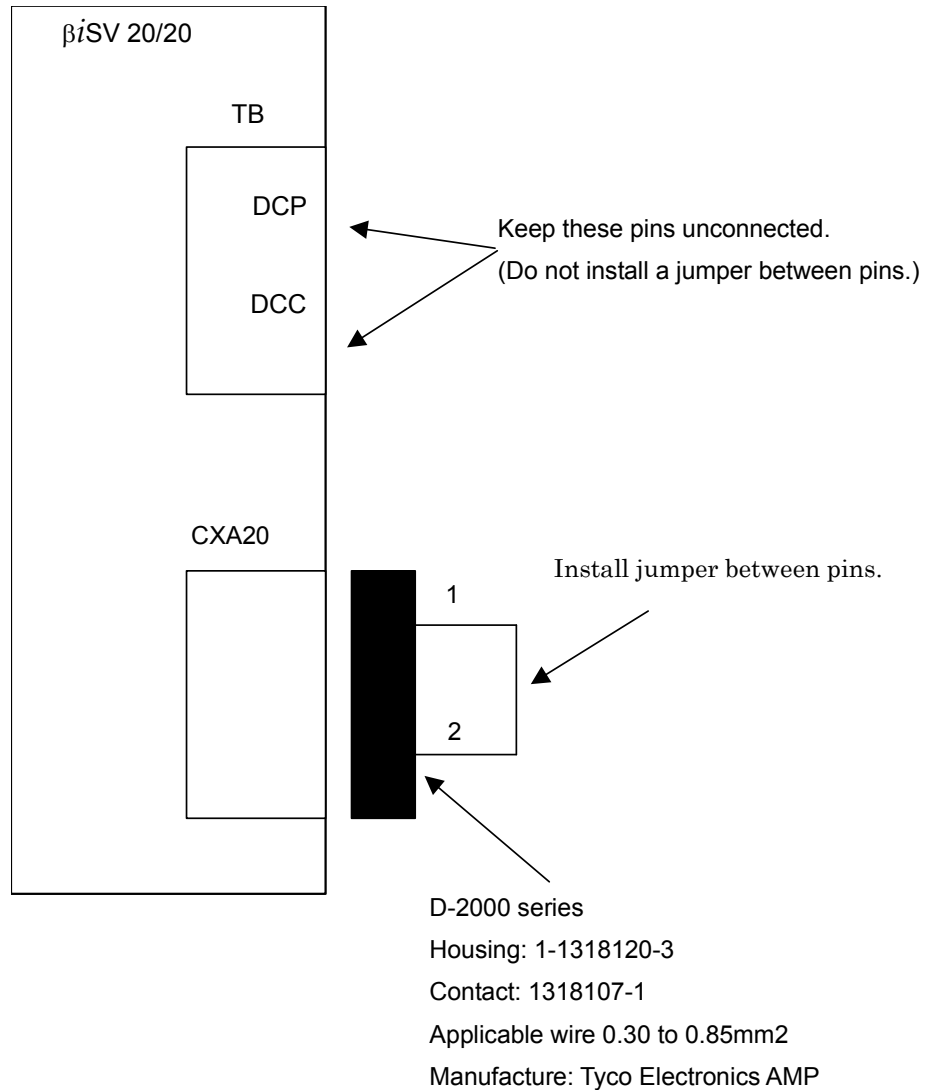

For connection tools, see subsection 9.2.3. of [I.SVM] for B-65322EN/02

⚠ WARNING

- Do not short between terminal “DCP” and terminal “DCC”.
- Do not connect this terminal “TB” to terminal “TB1(DCP/DCN)” of servo amplifier *αi* series.

Servo amplifier may be broken in case of above incorrect connection.

				TITLE	FANUC SERVO AMPLIFIER <i>βiSV</i> 20/20 DESCRIPTIONS		
				DRAW. No.	B-65322EN/02-03		
EDIT	DATE	DESIGN	DESCRIPTION	FANUC LTD			Page 21 / 23

11.5. Details of cable K12

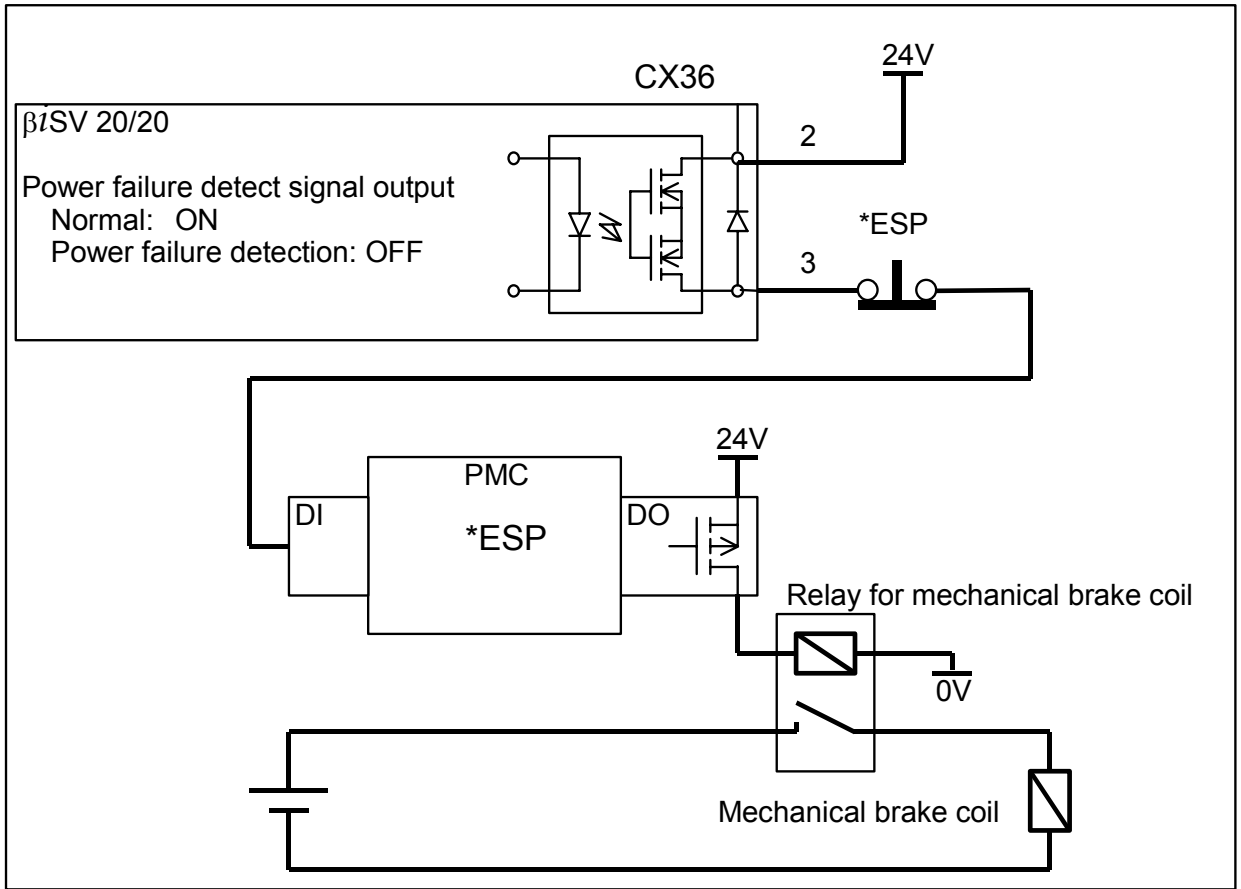

CX36 specification (Rated output)
 Output voltage: 30V Max.
 Output current : 200mA Max.

				TITLE	FANUC SERVO AMPLIFIER βiSV 20/20 DESCRIPTIONS		
				DRAW. No.	B-65322EN/02-03		
EDIT	DATE	DESIGN	DESCRIPTION	FANUC LTD			Page 22 / 23

12. Heat dissipation

The amount of heat dissipation depends on the current that flows through the servo amplifier and servo motor. For the current that flows through a servo motor, reference the continuous rated current of each servo motor. (For the continuous rated current of each servo motor, refer to the servo motor descriptions.) As the current that flows through a servo motor, the root-mean-square value of the current that flows through an actual servo motor on a machine can be used. The amount of heat dissipation indicated below assumes the use of HRV2.

(1) Total amount of heat dissipation

The total amount of heat dissipation is calculated according to the following expression:

$$\text{Total amount of heat dissipation} = a + K_{a1} \times b_1$$

a: Amount of heat dissipation determined by the βiSV [W]

K_{a1} : Coefficient determined by the βiSV [W/Arms]

b_1 : Current flowing through the servo motor [Arms]

Total amount of heat dissipation

Name	Specification	A [W]	K [W/Arms]
βiSV 20/20	H201	20	K_{a1} : 12.6

(2) Residual amount of heat in the cabinet

By placing the heat sink section outside the cabinet, the residual amount of heat in the cabinet can be calculated according to the expression below.

$$\text{Residual amount of heat in the cabinet} = a + K_{b1} \times b_1$$

a: Amount of heat dissipation determined by the βiSV [W]

K_{b1} : Coefficient determined by the βiSV [W/Arms]

b_1 : Current flowing through the servo motor [Arms]

Residual amount of heat in the cabinet

Name	Specification	a [W]	K [W/Arms]
βiSV 20/20	H201	20	K_{a1} : 12.6

				TITLE	FANUC SERVO AMPLIFIER βiSV 20/20 DESCRIPTIONS		
				DRAW. No.	B-65322EN/02-03		
EDIT	DATE	DESIGN	DESCRIPTION	FANUC LTD			Page 23 / 23



CENTER OF TECHNOLOGICAL INITIATIVES, LLC

info@cti-sumy.com.ua

Custom-made machines for you



Welding machine



Welding machine



Welding machine



Welding machine

Contact us:

 <http://cti-sumy.com.ua>

 info@cti-sumy.com.ua

sales1@cti-sumy.com.ua

 <https://www.facebook.com/cti.sumy>

 <https://www.youtube.com/channel/UCyYGmKVZ2FwZnoX4RV8Is0g>

We recomend!

This manual is brought to you by CTI LLC.

We have more than 10 years of experience in machine building and will gladly help you to increase productivity at your manufacturing facility!

Taking into account the peculiarities of your manufacture we can make a custom machine that will help you simplify the production process.



**Vibration meter
Vibrosticker**

Contacts:

<http://www.vibrosticker.com>

<http://www.ntk.net.ua/priboryi-lavina?lang=en>

<https://www.linkedin.com/company/lavina-vibro>

ntk.vdk@gmail.com